

## ***OWNER'S MANUAL***

Operation  
Maintenance  
Specifications

All information in this Owner's Manual is current at the time of publication. However, HYUNDAI reserves the right to make changes at any time so that our policy of continual product improvement may be carried out.

This manual applies to all models of this vehicle and includes descriptions and explanations of optional as well as standard equipment.

As a result, you may find material in this manual that does not apply to your specific vehicle.

Please note that some models are equipped with Right-Hand Drive (RHD). The explanations and illustrations for some operations in RHD models are opposite of those written in this manual.

## **CAUTION: MODIFICATIONS TO YOUR HYUNDAI**

Your HYUNDAI should not be modified in any way. Such modifications may adversely affect the performance, safety or durability of your HYUNDAI and may, in addition, violate conditions of the limited warranties covering the vehicle. Certain modifications may also be in violation of regulations established by the Department of Transportation and other government agencies in your country.

## **TWO-WAY RADIO OR CELLULAR TELEPHONE INSTALLATION**

Your vehicle is equipped with electronic fuel injection and other electronic components. It is possible for an improperly installed/adjusted two-way radio or cellular telephone to adversely affect electronic systems. For this reason, we recommend that you carefully follow the radio manufacturer's instructions or consult your HYUNDAI dealer for precautionary measures or special instructions if you choose to install one of these devices.

## SAFETY AND VEHICLE DAMAGE WARNING

This manual includes information titled as DANGER, WARNING, CAUTION and NOTICE. These titles indicate the following:

### DANGER

**DANGER** indicates a hazardous situation which, if not avoided, will result in death or serious injury.

### WARNING

**WARNING** indicates a hazardous situation which, if not avoided, could result in death or serious injury.

### CAUTION

**CAUTION** indicates a hazardous situation which, if not avoided, could result in minor or moderate injury.

### **NOTICE**

**NOTICE** indicates a situation which, if not avoided, could result in vehicle damage.

## FOREWORD

Congratulations, and thank you for choosing HYUNDAI. We are pleased to welcome you to the growing number of distinguished people who drive HYUNDAIS. We are very proud of the advanced engineering and high-quality construction of each HYUNDAI we build.

Your Owner's Manual will introduce you to the features and operation of your new HYUNDAI. To become familiar with your new HYUNDAI, so that you can fully enjoy it, read this Owner's Manual carefully before driving your new vehicle.

This manual contains important safety information and instructions intended to familiarize you with your vehicle's controls and safety features so you can safely operate your vehicle.

This manual also contains information on maintenance designed to enhance safe operation of the vehicle. It is recommended that all service and maintenance on your car be performed by an authorized HYUNDAI dealer. HYUNDAI dealers are prepared to provide high-quality service, maintenance and any other assistance that may be required.

This Owner's Manual should be considered a permanent part of your vehicle, and should be kept in the vehicle so you can refer to it at any time. The manual should stay with the vehicle if you sell it to provide the next owner with important operating, safety and maintenance information.

## HYUNDAI MOTOR COMPANY

### CAUTION

**Severe engine and transmission damage may result from the use of poor quality fuels and lubricants that do not meet HYUNDAI specifications. You must always use high quality fuels and lubricants that meet the specifications listed on Page 8-6 in the Vehicle Specifications section of the Owner's Manual.**

Copyright 2017 HYUNDAI Motor Company. All rights reserved. No part of this publication may be reproduced, stored in any retrieval system or transmitted in any form or by any means without the prior written permission of HYUNDAI Motor Company.

## HOW TO USE THIS MANUAL

We want to help you get the greatest possible driving pleasure from your vehicle. Your Owner's Manual can assist you in many ways. We strongly recommend that you read the entire manual. In order to minimize the chance of death or injury, you must read the WARNING and CAUTION sections in the manual.

Illustrations complement the words in this manual to best explain how to enjoy your vehicle. By reading your manual, you will learn about features, important safety information, and driving tips under various road conditions.

The general layout of the manual is provided in the Table of Contents. Use the index when looking for a specific area or subject; it has an alphabetical listing of all information in your manual.

Sections: This manual has eight chapters plus an index. Each chapter begins with a brief list of contents so you can tell at a glance if that section has the information you want.

## SAFETY MESSAGES

Your safety, and the safety of others, is very important. This Owner's Manual provides you with many safety precautions and operating procedures. This information alerts you to potential hazards that may hurt you or others, as well as damage to your vehicle.

Safety messages found on vehicle labels and in this manual describe these hazards and what to do to avoid or reduce the risks.

Warnings and instructions contained in this manual are for your safety. Failure to follow safety warnings and instructions can lead to serious injury or death.

Throughout this manual DANGER, WARNING, CAUTION, NOTICE and the SAFETY ALERT SYMBOL will be used.



This is the safety alert symbol. It is used to alert you to potential physical injury hazards. Obey all safety messages that follow this symbol to avoid possible injury or death. The safety alert symbol precedes the signal words DANGER, WARNING and CAUTION.

### DANGER

**DANGER indicates a hazardous situation which, if not avoided, will result in death or serious injury.**

### WARNING

**WARNING indicates a hazardous situation which, if not avoided, could result in death or serious injury.**



**CAUTION**

**CAUTION** indicates a hazardous situation which, if not avoided, could result in minor or moderate injury.

**NOTICE**

**NOTICE** indicates a situation which, if not avoided, could result in vehicle damage.

## FUEL REQUIREMENTS

### *Unleaded*

For the optimal vehicle performance, we recommend you use unleaded gasoline which has an octane rating of RON (Research Octane Number) 95 / AKI (Anti Knock Index) 91 or higher.



**CAUTION**

**Using unleaded gasoline with an octane rating lower than RON 95 could result in loss of engine power and may cause damage to the engine.**

Your new vehicle is designed to obtain maximum performance with UNLEADED FUEL, as well as minimize exhaust emissions and spark plug fouling.



**CAUTION**

**NEVER USE LEADED FUEL. The use of leaded fuel is detrimental to the catalytic converter and will damage the engine control system's oxygen sensor and affect emission control.**

**Never add any fuel system cleaning agents to the fuel tank other than what has been specified (We recommend that you consult an authorized HYUNDAI dealer for details.)**



**WARNING**

- **Do not "top off" after the nozzle automatically shuts off when refueling.**
- **Always check that the fuel cap is installed securely to prevent fuel spillage in the event of an accident.**

**Leaded (if equipped)**

For some countries, your vehicle is designed to use leaded gasoline. When you are going to use leaded gasoline, we recommend that you ask an authorized HYUNDAI dealer.

Octane rating of leaded gasoline is same with unleaded one.

**Gasoline containing alcohol and methanol**

Gasohol, a mixture of gasoline and ethanol (also known as grain alcohol), and gasoline or gasohol containing methanol (also known as wood alcohol) are being marketed along with or instead of leaded or unleaded gasoline.

Do not use gasohol containing more than 10% ethanol, and do not use gasoline or gasohol containing any methanol. Either of these fuels may cause drivability problems and damage to the fuel system, engine control system and emission control system.

Discontinue using gasohol of any kind if drivability problems occur.

Vehicle damage or driveability problems may not be covered by the manufacturer's warranty if they result from the use of:

1. Gasohol containing more than 10% ethanol.
2. Gasoline or gasohol containing methanol.
3. Leaded fuel or leaded gasohol.

 **CAUTION**

**Never use gasohol which contains methanol. Discontinue use of any gasohol product which impairs drivability.**

**Other fuels**

Using fuel additives such as:

- Silicone fuel additive
- MMT (Magnanese, Mn) fuel additive
- Ferrocene (iron-based) fuel additive
- Other metallic-based fuel additives

may result in cylinder misfire, poor acceleration, engine stalling, damage to the catalyst, or abnormal corrosion, and may cause damage to the engine resulting in a reduction in the overall life of the powertrain.

**NOTICE**

**Damage to the fuel system or performance problem caused by the use of these fuels may not be covered by your New Vehicle Limited Warranty.**

### ***Use of MTBE***

HYUNDAI recommends avoiding fuels containing MTBE (Methyl Tertiary Butyl Ether) over 15.0% vol. (Oxygen Content 2.7% weight) in your vehicle.

Fuel containing MTBE over 15.0% vol. (Oxygen Content 2.7% weight) may reduce vehicle performance and produce vapor lock or hard starting.



### **CAUTION**

**Your New Vehicle Limited Warranty may not cover damage to the fuel system and any performance problems that are caused by the use of fuels containing methanol or fuels containing MTBE (Methyl Tertiary Butyl Ether) over 15.0% vol. (Oxygen Content 2.7% weight.)**

### ***Do not use methanol***

Fuels containing methanol (wood alcohol) should not be used in your vehicle. This type of fuel can reduce vehicle performance and damage components of the fuel system, engine control system and emission control system.

### ***Fuel Additives***

HYUNDAI recommends that you use unleaded gasoline which has an octane rating of RON (Research Octane Number) 95 / AKI (Anti Knock Index) 91 or higher.

For customers who do not use good quality gasolines including fuel additives regularly, and have problems starting or the engine does not run smoothly, one bottle of additive added to the fuel tank according to the maintenance schedule is recommended (refer to chapter 7, "Normal Maintenance Schedule").

Additives are available from your authorized HYUNDAI dealer along with information on how to use them. Do not mix other additives.

### ***Operation in foreign countries***

If you are going to drive your vehicle in another country, be sure to:

- Observe all regulations regarding registration and insurance.
- Determine that acceptable fuel is available.



## VEHICLE MODIFICATIONS

- This vehicle should not be modified. Modification of your vehicle could affect its performance, safety or durability and may even violate governmental safety and emissions regulations.  
In addition, damage or performance problems resulting from any modification may not be covered under warranty.
- If you use unauthorized electronic devices, it may cause the vehicle to operate abnormally, wire damage, battery discharge and fire. For your safety, do not use unauthorized electronic devices.

## VEHICLE BREAK-IN PROCESS

By following a few simple precautions for the first 1,000 km (600 miles) you may add to the performance, economy and life of your vehicle.

- Do not race the engine.
- While driving, keep your engine speed (rpm, or revolutions per minute) within 3,000 rpm.
- Do not maintain a single speed for long periods of time, either fast or slow. Varying engine speed is needed to properly break-in the engine.
- Avoid hard stops, except in emergencies, to allow the brakes to seat properly.
- Do not tow a trailer during the first 2,000 km (1,200 miles) of operation.
- Do not use Launch Control during the break-in process.

## RETURNING USED VEHICLES (FOR EUROPE)

HYUNDAI promotes an environmentally sound treatment for end of life vehicles and offers to take back your HYUNDAI end of life vehicles in accordance with the European Union (EU) End of Life Vehicles Directive.

You can get detailed information from your national HYUNDAI homepage.



## TABLE OF CONTENTS

Your vehicle at a glance	1
Safety system of your vehicle	2
Convenient features of your vehicle	3
Multimedia System	4
Driving your vehicle	5
What to do in an emergency	6
Maintenance	7
Specifications & Consumer information	8
Index	I

# Your vehicle at a glance

Exterior overview (I) .....	1-2
Exterior overview (II) .....	1-3
Interior overview.....	1-4
Instrument panel overview (I).....	1-5
Instrument panel overview (II).....	1-6
Engine compartment .....	1-7

## EXTERIOR OVERVIEW (I)

■ Front view



- 1. Door locks.....3-11
- 2. Panorama sunroof .....3-32
- 3. Hood .....3-37
- 4. Outside rearview mirror .....3-23
- 5. Head lamp.....3-79, 7-62
- 6. DRL (Daytime Running Light) .....3-86, 7-62
- 7. Front windshield wiper blades .....3-91, 7-31
- 8. Parking assist system.....3-100
- 9. Tires and wheels .....7-37, 8-4

The actual shape may differ from the illustration.

OPDEN017001

## EXTERIOR OVERVIEW (II)

### ■ Rear view



The actual shape may differ from the illustration.

1. Fuel filler door.....3-40
2. Tailgate .....3-38
3. Rear window wiper blade .....3-91, 7-32
4. Defroster .....3-116
5. Antenna .....4-2
6. Rear combination lamp .....7-66
7. High mounted stop lamp .....7-69
8. Rear fog lamp.....3-84, 7-68
9. Rear parking assist system .....3-96
10. Rearview camera.....3-95
11. Towing hook.....6-38

## INTERIOR OVERVIEW

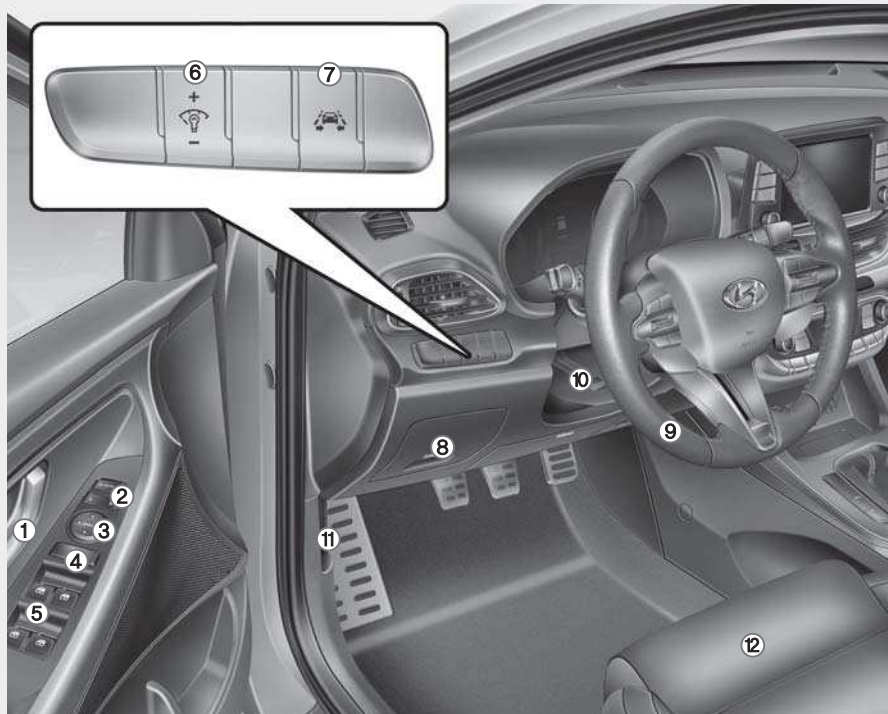

- 1. Inside door handle .....3-12
- 2. Outside rearview mirror folding .....3-25
- 3. Outside rearview mirror control .....3-24
- 4. Power window lock switch .....3-30
- 5. Power window switches .....3-27
- 6. Instrument panel illumination control switch .....3-44
- 7. Lane keeping assist system (LKAS)/ Lane departure warning system (LDWS) .....5-64
- 8. Fuse box .....7-48
- 9. Steering wheel .....3-19
- 10. Steering wheel tilt/telescopic lever ..3-20
- 11. Hood release lever .....3-37
- 12. Seat .....2-4

The actual shape may differ from the illustration.

OPDEN017003

## INSTRUMENT PANEL OVERVIEW (I)



The actual shape may differ from the illustration.

- 1. Instrument cluster .....3-43
- 2. Light control/Turn signals .....3-79
- 3. Wiper/Washer.....3-91
- 4. Steering wheel audio controls/  
Bluetooth® wireless technology  
hands-free controls .....4-3
- 5. Cruise control.....5-82
- 6. Driver's front air bag.....2-47
- 7. Key ignition switch/  
Engine Start/Stop button .....5-6
- 8. Audio system/  
Navigation system .....4-8
- 9. Hazard warning flasher switch.....6-2
- 10. Central door lock switch .....3-13
- 11. Automatic climate control  
system .....3-103
- 12. Passenger's front air bag .....2-47
- 13. Glove box .....3-119
- 14. Console box .....3-119



## INSTRUMENT PANEL OVERVIEW (II)

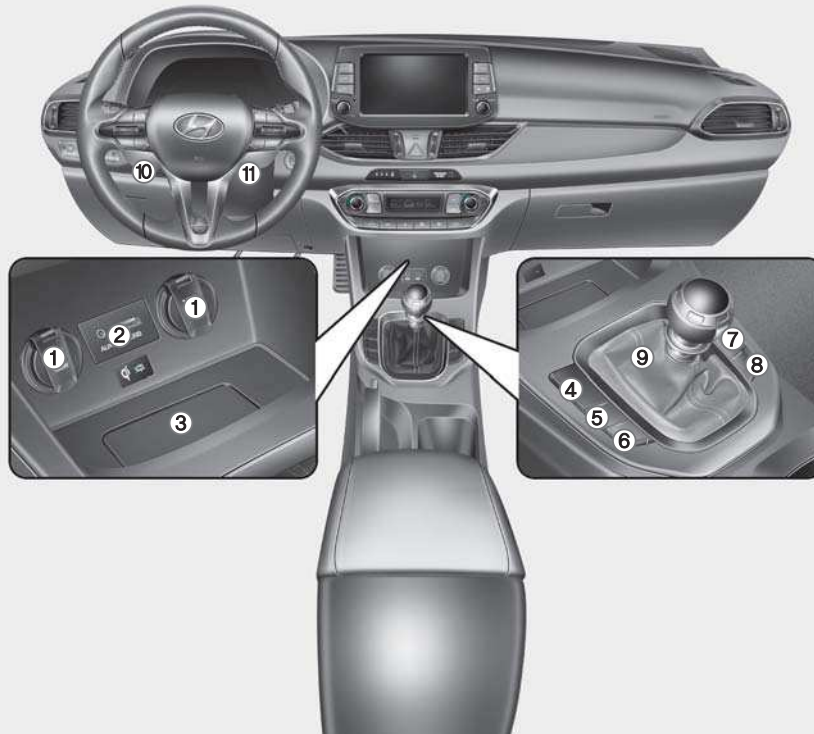

- 1. Power outlet .....3-123
- 2. Aux, USB and iPod® .....4-2
- 3. Wireless cellular phone charging system .....3-125
- 4. Seat warmer .....2-20
- 5. Heated steering wheel .....3-21
- 6. ESC OFF button .....5-29
- 7. Parking assist system ON button/..3-100  
Rear parking assist system  
OFF button .....3-98
- 8. Idle stop and go (ISG) OFF button ..5-44
- 9. Manual transmission shift lever .....5-14
- 10. DRIVE MODE button .....5-40
- 11. N button .....5-41

The actual shape may differ from the illustration.

OPDEN017004

## ENGINE COMPARTMENT



- 1. Engine coolant reservoir/  
Engine coolant cap .....7-22
- 2. Brake/clutch fluid reservoir .....7-25
- 3. Air cleaner .....7-27
- 4. Engine oil dipstick .....7-20
- 5. Engine oil filler cap .....7-20
- 6. Windshield washer fluid reservoir .....7-26
- 7. Fuse box .....7-49
- 8. Battery .....7-33

The actual engine compartment in the vehicle may differ from the illustration.

OPDEN077088

# Safety system of your vehicle

This chapter provides you with important information about how to protect yourself and your passengers. It explains how to properly use your seats and seat belts, and how your air bags work. Additionally, this chapter explains how to properly restrain infants and children in your vehicle.

<b>Important safety precautions</b> .....	2-2	<b>Child restraint system (CRS)</b> .....	2-34
Always wear your seat belt .....	2-2	Our recommendation:Children always in the rear	2-34
Restrain all children .....	2-2	Selecting a Child Restraint System (CRS) .....	2-35
Air bag hazards .....	2-2	Installing a Child Restraint System (CRS).....	2-37
Driver distraction .....	2-2	<b>Air bag - supplemental restraint system</b> .....	2-45
Control your speed .....	2-3	Where are the air bags? .....	2-47
Keep your vehicle in safe condition .....	2-3	How does the air bags system operate? .....	2-52
<b>Seats</b> .....	2-4	What to expect after an air bag inflates .....	2-56
Safety precautions .....	2-5	Why didn't my air bag go off in a collision? .....	2-57
Front seats .....	2-6	SRS care .....	2-62
Rear seats .....	2-12	Additional safety precautions .....	2-63
Headrest .....	2-15	Air bag warning labels .....	2-63
Seat warmers and air ventilation seats.....	2-19		
<b>Seat belts</b> .....	2-22		
Seat belt safety precautions .....	2-22		
Seat belt warning light .....	2-23		
Seat belt restraint system .....	2-25		
Additional seat belt safety precautions .....	2-31		
Care of seat belts .....	2-33		

### IMPORTANT SAFETY PRECAUTIONS

You will find many safety precautions and recommendations throughout this section, and throughout this manual. The safety precautions in this section are among the most important.

#### Always wear your seat belt

A seat belt is your best protection in all types of accidents. Air bags are designed to supplement seat belts, not replace them. So even though your vehicle is equipped with air bags, **ALWAYS** make sure you and your passengers wear your seat belts, and wear them properly.

#### Restrain all children

All children under age 13 should ride in your vehicle properly restrained in a rear seat, not the front seat. Infants and small children should be restrained in an appropriate Child Restraint System. Larger children should use a booster seat with the lap/shoulder belt until they can use the seat belt properly without a booster seat.

#### Air bag hazards

While air bags can save lives, they can also cause serious or fatal injuries to occupants who sit too close to them, or who are not properly restrained. Infants, young children, and short adults are at the greatest risk of being injured by an inflating air bag. Follow all instructions and warnings in this manual.

#### Driver distraction

Driver distraction presents a serious and potentially deadly danger, especially for inexperienced drivers. Safety should be the first concern when behind the wheel and drivers need to be aware of the wide array of potential distractions, such as drowsiness, reaching for objects, eating, personal grooming, other passengers, and using cellular phones.

Drivers can become distracted when they take their eyes and attention off the road or their hands off the wheel to focus on activities other than driving. To reduce your risk of distraction and an accident:

- **ALWAYS** set up your mobile devices (i.e., MP3 players, phones, navigation units, etc.) when your vehicle is parked or safely stopped.
- **ONLY** use your mobile device when allowed by laws and conditions permit safe use. **NEVER** text or email while driving. Most countries have laws prohibiting drivers from texting. Some countries and cities also prohibit drivers from using handheld phones.

- 
- NEVER let the use of a mobile device distract you from driving. You have a responsibility to your passengers and others on the road to always drive safely, with your hands on the wheel as well as your eyes and attention on the road.

### Control your speed

Excessive speed is a major factor in crash injuries and deaths. Generally, the higher the speed, the greater the risk, but serious injuries can also occur at lower speeds. Never drive faster than is safe for current conditions, regardless of the maximum speed posted.

### Keep your vehicle in safe condition

Having a tire blowout or a mechanical failure can be extremely hazardous. To reduce the possibility of such problems, check your tire pressures and condition frequently, and perform all regularly scheduled maintenance.

## SEATS

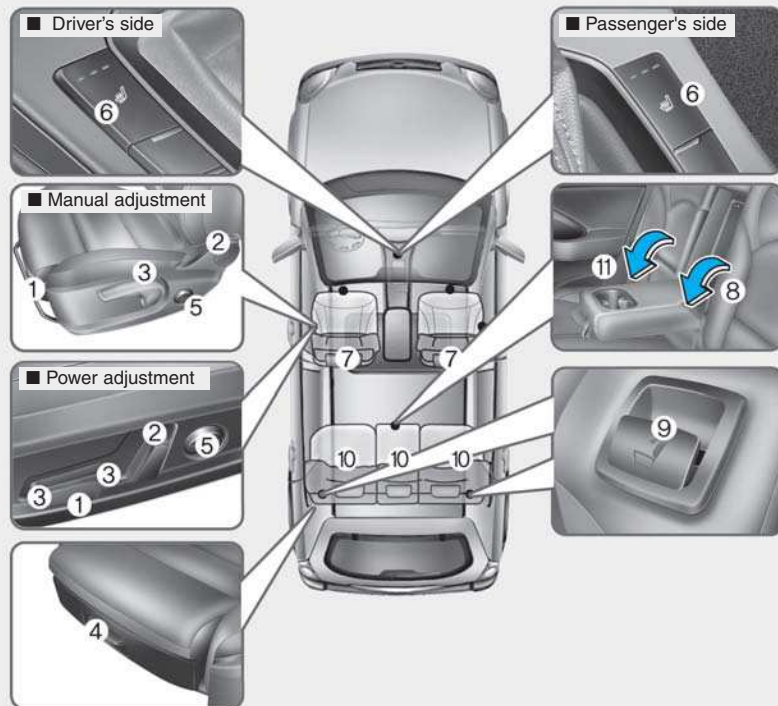

### Front seat

- (1) Forward and backward
- (2) Seatback angle
- (3) Seat cushion height\*
- (4) Seat cushion length\*
- (5) Lumbar support\*
- (6) Seat warmer\*
- (7) Headrest

### Rear seat

- (8) Armrest\*
- (9) Seatback folding
- (10) Headrest
- (11) Carrying long/narrow cargo\*

\* : if equipped

OPDEN037001

## Safety precautions

Adjusting the seats so that you are sitting in a safe, comfortable position plays an important role in driver and passenger safety together with the seat belts and air bags in an accident.

### WARNING

**Do not use a cushion that reduces friction between the seat and the passenger. The passenger's hips may slide under the lap portion of the seat belt during an accident or a sudden stop.**

**Serious or fatal internal injuries could result because the seat belt cannot operate properly.**

## Air bags

You can take steps to reduce the risk of being injured by an inflating air bag. Sitting too close to an air bag greatly increases the risk of injury in the event the air bag inflates. Move your seat as far back as possible from front air bags, while still maintaining control of the vehicle.

### WARNING

**To reduce the risk of serious injury or death from an inflating air bag, take the following precautions:**

- **Adjust the driver's seat as far to the rear as possible maintaining the ability to control the vehicle.**
- **Adjust the front passenger seat as far to the rear as possible.**

**(Continued)**

**(Continued)**

- **Hold the steering wheel by the rim with hands at the 9 o'clock and 3 o'clock positions to minimize the risk of injuries to your hands and arms.**
- **NEVER place anything or anyone between you and the air bag.**
- **Do not allow the front passenger to place feet or legs on the dashboard to minimize the risk of leg injuries.**

### Seat belts

Always fasten your seat belt before starting any trip.

At all times, passengers should sit upright and be properly restrained. Infants and small children must be restrained in appropriate Child Restraint Systems. Children who have outgrown a booster seat and adults must be restrained using the seat belts.

#### WARNING

Take the following precautions when adjusting your seat belt:

- NEVER use one seat belt for more than one occupant.
- Always position the seatback upright with the lap portion of the seat belt snug and low across the hips.
- NEVER allow children or small infants to ride on a passenger's lap.

(Continued)

(Continued)

- Do not route the seat belt across your neck, across sharp edges, or reroute the shoulder strap away from your body.
- Do not allow the seat belt to become caught or jammed.

### Front seats

The front seat can be adjusted by using the control lever (or knob) or switches located on the outside of the seat cushion. Before driving, adjust the seat to the proper position so that you can easily control the steering wheel, foot pedals and controls on the instrument panel.

#### WARNING

Take the following precautions when adjusting your seat:

- NEVER attempt to adjust the seat while the vehicle is moving. The seat could respond with unexpected movement and may cause loss of vehicle control resulting in an accident.
- Do not place anything under the front seats. Loose objects in the driver's foot area could interfere with the operation of the foot pedals, causing an accident.

(Continued)



**(Continued)**

- Do not allow anything to interfere with the normal position and proper locking of the seat-back.
- Do not place a cigarette lighter on the floor or seat. When you operate the seat, gas may exit out of the lighter causing a fire.
- Use extreme caution when picking up small objects trapped under the seats or between the seat and the center console. Your hands might be cut or injured by the sharp edges of the seat mechanism.
- If there are occupants in the rear seats, be careful while adjusting the front seat position.

**⚠ CAUTION****To prevent injury:**

- Do not adjust your seat while wearing your seat belt. Moving the seat cushion forward may cause strong pressure on your abdomen.
- Do not allow your hands or fingers to get caught in the seat mechanisms while the seat is moving.

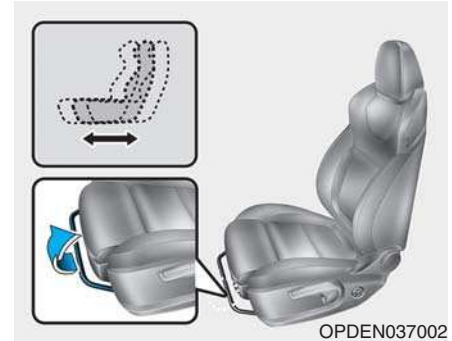
**Manual adjustment****Forward and rearward adjustment**

To move the seat forward or rearward:

1. Pull up the seat slide adjustment lever and hold it.
2. Slide the seat to the position you desire.
3. Release the lever and make sure the seat is locked in place. Move forward and rearward without using the lever. If the seat moves, it is not locked properly.

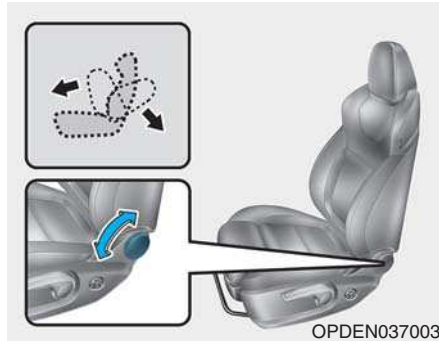

### Seatback angle

To recline the seatback:

1. Roll the seatback knob rearward.
2. Adjust the seatback to the position you desire.

### Reclining seatback

Sitting in a reclined position when the vehicle is in motion can be dangerous. Even when buckled up, the protections of your restraint system (seat belts and/or air bags) is greatly reduced by reclining your seatback.

#### **! WARNING**

**NEVER** ride with a reclined seatback when the vehicle is moving.

**Riding with a reclined seatback increases your chance of serious or fatal injuries in the event of a collision or sudden stop.**

**Drivers and passengers should ALWAYS sit well back in their seats, properly belted, and with the seatbacks upright.**

Seat belts must be snug against your hips and chest to work properly. When the seatback is reclined, the shoulder belt cannot do its job because it will not be snug against your chest. Instead, it will be in front of you. During an accident, you could be thrown into the seat belt, causing neck or other injuries.

The more the seatback is reclined, the greater chance the passenger's hips will slide under the lap belt or the passenger's neck will strike the shoulder belt.

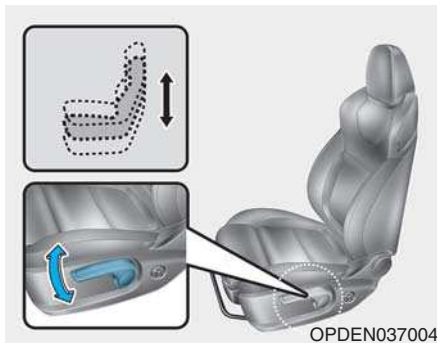

### Seat cushion height (if equipped)

To change the height of the seat cushion:

- Push down the lever several times, to lower the seat cushion.
- Pull up the lever several times, to raise the seat cushion.

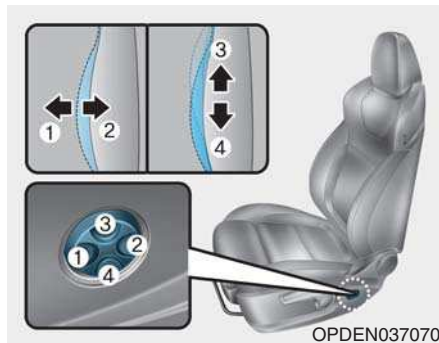

### Lumbar support (if equipped)

The lumbar support can be adjusted by pressing the lumbar support switch.

- Press the front portion of the switch (1) to increase support or the rear portion of the switch (2) to decrease support.
- To move the support position up or down, press switch (3) or (4). The lumbar support does not operate up or down when the lumbar support is in the rearmost position. In this case, to use the system, slightly increase support by pushing the front portion of the switch (1).

### Power adjustment

#### ⚠ WARNING

**NEVER** allow children in the vehicle unattended. The power seats are operable when the engine is turned off.

#### NOTICE

To prevent damage to the seats:

- **Always stop adjusting the seats when the seat has been adjusted as far forward or rearward as possible.**
- **Do not adjust the seats longer than necessary when the engine is turned off. This may result in unnecessary battery drain.**
- **Do not operate two or more seats at the same time. This may result in an electrical malfunction.**

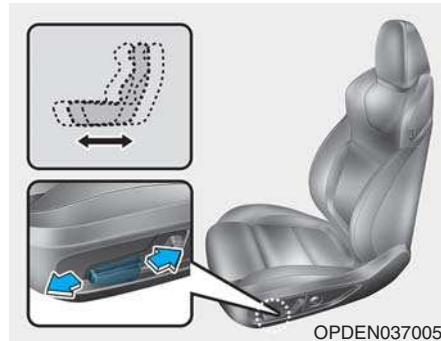

### Forward and rearward adjustment

To move the seat forward or rearward:

1. Push the control switch forward or rearward.
2. Release the switch once the seat reaches the desired position.

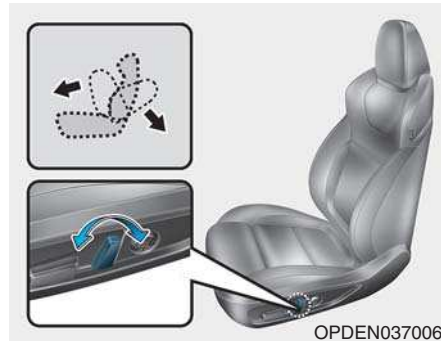

### Seatback angle

To recline the seatback:

1. Push the control switch forward or rearward.
2. Release the switch once the seatback reaches the desired position.

### Reclining seatback

Sitting in a reclined position when the vehicle is in motion can be dangerous. Even when buckled up, the protections of your restraint system (seat belts and air bags) is greatly reduced by reclining your seatback.

### WARNING

**NEVER** ride with a reclined seatback when the vehicle is moving. Riding with a reclined seatback increases your chance of serious or fatal injuries in the event of a collision or sudden stop.

Driver and passengers should **ALWAYS** sit well back in their seats, properly belted, and with the seatbacks upright.

Seat belts must be snug against your hips and chest to work properly. When the seatback is reclined, the shoulder belt cannot do its job because it will not be snug against your chest. Instead, it will be in front of you. During an accident, you could be thrown into the seat belt, causing neck or other injuries.

The more the seatback is reclined, the greater chance the passenger's hips will slide under the lap belt or the passenger's neck will strike the shoulder belt.

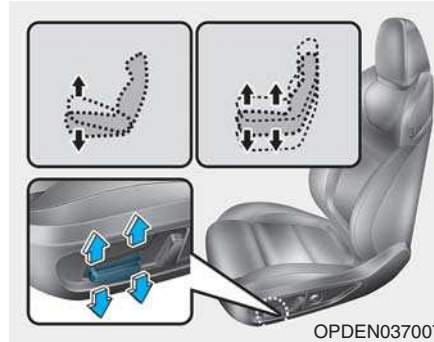

#### Seat cushion height (if equipped)

To change the height of the seat cushion:

1. • Push the front portion of the control switch up to raise or down to lower the front part of the seat cushion.
  - Push the rear portion of the control switch up to raise or down to lower the height of the seat cushion.
2. Release the switch once the seat reaches the desired position.

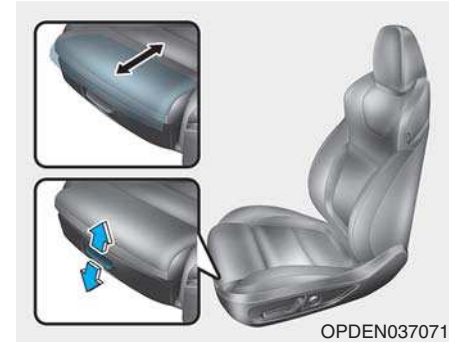

#### Seat cushion length (if equipped)

To change the length of the seat cushion:

1. Pull up the lever to lengthen the cushion length or pull down the lever to shorten the cushion length.
2. Release the switch once the cushion reaches the desired position.

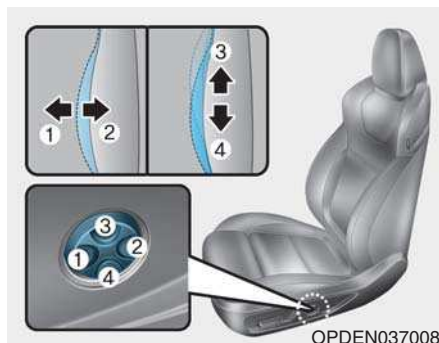

### Lumbar support (if equipped)

The lumbar support can be adjusted by pressing the lumbar support switch.

- Press the front portion of the switch (1) to increase support or the rear portion of the switch (2) to decrease support.
- To move the support position up or down, press switch (3) or (4). The lumbar support does not operate up or down when the lumbar support is in the rearmost position. In this case, to use the system, slightly increase support by pushing the front portion of the switch (1).

### Seatback pocket (if equipped)

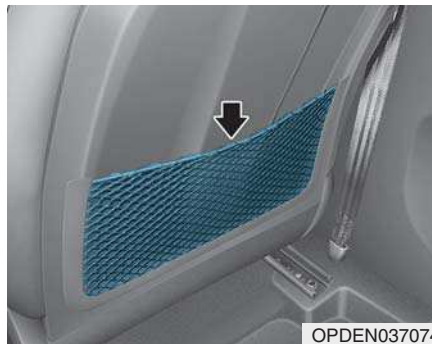

The seatback pocket is provided on the back of the front seatbacks.

### CAUTION

**Do not put heavy or sharp objects in the seatback pockets. In an accident they could come loose from the pocket and injure occupants.**

### Rear seats

#### *Folding the rear seat*

The rear seatbacks can be folded to facilitate carrying long items or to increase the luggage capacity of the vehicle.

### WARNING

- **Never allow passengers to sit on top of the folded down seatback while the vehicle is moving. This is not a proper seating position and no seat belts are available for use. This could result in serious injury or death in case of an accident or sudden stop.**
- **Objects carried on the folded down seatback should not extend higher than the top of the front seatbacks. This could allow cargo to slide forward and cause injury or damage during sudden stops.**



To fold down the rear seatback:

1. Set the front seatback to the upright position and if necessary, slide the front seat forward.
2. Lower the rear headrests to the lowest position.



3. Locate the seatbelt toward the outboard position before folding down the seatback to avoid the seatbelt system interfering with the seatback.

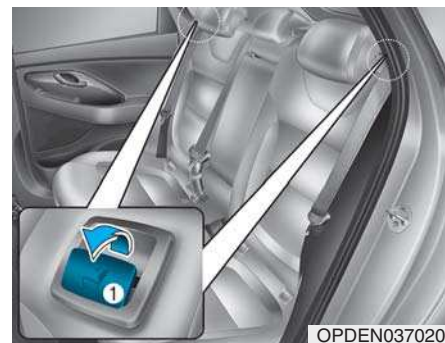

4. Pull up the seatback folding lever (1), then fold the seat toward the front of the vehicle.



5. To use the rear seat, lift and push the seatback rearward.

Push the seatback firmly until it clicks into place. Make sure the seatback is locked in place.

### **⚠ WARNING**

When returning the rear seatback from a folded to an upright position, hold the seatback and return it slowly. Ensure that the seatback is completely locked into its upright position by pushing on the top of the seatback. In an accident or sudden stop, the unlocked seatback could allow cargo to move forward with great force and enter the passenger compartment, which could result in serious injury or death.

### **⚠ WARNING**

Do not place objects in the rear seats, since they cannot be properly secured and may hit vehicle occupants in a collision causing serious injury or death.

### **⚠ WARNING**

Make sure the engine is off, the shift lever is in P (Park), and the parking brake is securely applied whenever loading or unloading cargo. Failure to take these steps may allow the vehicle to move if the shift lever is inadvertently moved to another position.



### Armrest (if equipped)



The armrest is located in the center of the rear seat. Pull the armrest down from the seatback to use it.

### Carrying long/narrow cargo (if equipped)



Additional cargo space is provided to accommodate long/narrow cargo (skis, poles, etc.) not able to fit properly in the luggage compartment when closed.

1. Pull the armrest down.
2. Pull the cover down while pushing the release lever down.

### CAUTION

- Be careful when loading cargo through the rear passenger seats to prevent damage to the vehicle interior.
- When cargo is loaded through the rear passenger seats, ensure the cargo is properly secured to prevent it from moving while driving.

### WARNING

**Cargo should always be secured to prevent it from being thrown about the vehicle in a collision and causing injury to the vehicle occupants. Do not place objects in the rear seats, since they cannot be properly secured and may hit the front seat occupants in a collision.**

### Headrest

The vehicle's front and rear seats have adjustable headrests. The headrests provide comfort for passengers, but more importantly they are designed to help protect passengers from whiplash and other neck and spinal injuries during an accident, especially in a rear impact collision.

#### WARNING

To reduce the risk of serious injury or death in an accident, take the following precautions when adjusting your headrests:

- Always properly adjust the headrests for all passengers **BEFORE** starting the vehicle.
- **NEVER** let anyone ride in a seat with the headrest removed.

(Continued)

(Continued)



- Adjust the headrests so the middle of the headrest is at the same height as the height of the top of the eyes.
- **NEVER** adjust the headrest position of the driver's seat when the vehicle is in motion.
- Adjust the headrest as close to the passenger's head as possible. Do not use a seat cushion that holds the body away from the seatback.
- Make sure the headrest locks into position after adjusting it.

#### NOTICE

To prevent damage, **NEVER** hit or pull on the headrests.

#### CAUTION

When there is no occupant in the rear seats, adjust the height of the headrest to the lowest position. The rear seat headrest can reduce the visibility of the rear area.

## Front seat headrests

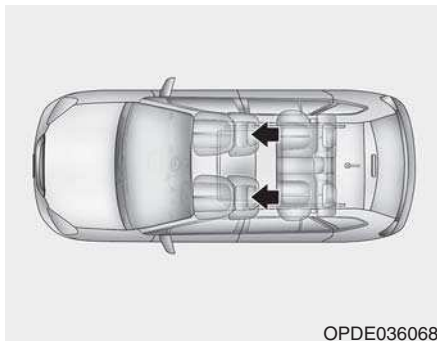

OPDE036068

The driver's and front passenger's seats are equipped with adjustable headrests for the passengers safety and comfort.

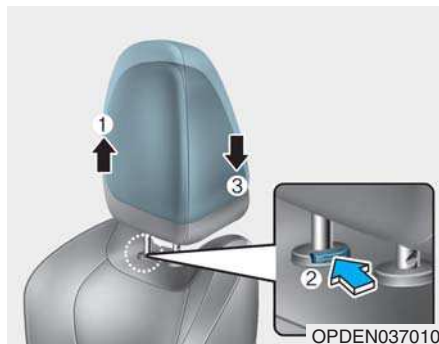

OPDEN037010

### Adjusting the height up and down

To raise the headrest:

1. Pull it up to the desired position (1).

To lower the headrest:

1. Push and hold the release button (2) on the headrest support.
2. Lower the headrest to the desired position (3).

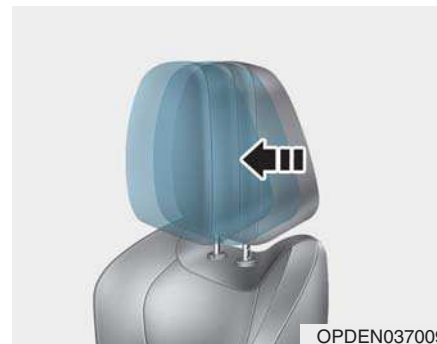

OPDEN037009

### Forward and rearward adjustment

The headrest may be adjusted forward to 3 different positions by pulling the headrest forward to the desired detent. To adjust the headrest to its furthest rearwards position, pull it fully forward to the farthest position and release it.

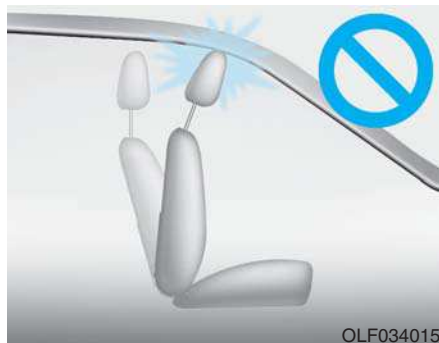

### NOTICE

If you recline the seatback towards the front with the headrest and seat cushion raised, the headrest may come in contact with the sunvisor or other parts of the vehicle.

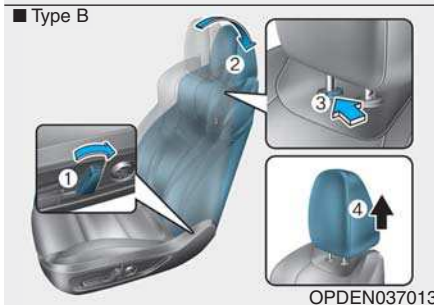
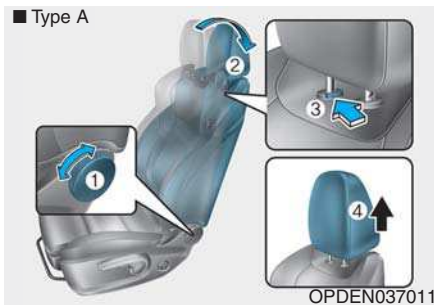

3. Press the headrest release button (3) while pulling the headrest up (4).

### ⚠ WARNING

**NEVER** allow anyone to travel in a seat with the headrest removed.

### Removal/Reinstall

To remove the headrest:

1. Recline the seatback (2) using the seatback angle knob or switch (1).
2. Raise the headrest as far as it can go.

■ Type A

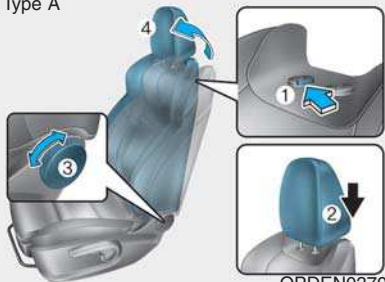

OPDEN037012

■ Type B



OPDEN037014

4. Recline the seatback (4) using the seatback angle knob or switch (3).

**! WARNING**

**Always make sure the headrest locks into position after reinstalling and adjusting it properly.**

**Rear seat headrests**

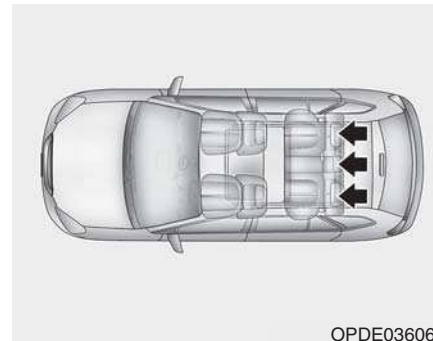

OPDE036069

The rear seats are equipped with headrests in all the seating positions for the passenger's safety and comfort.

To reinstall the headrest :

1. Recline the seatback.
2. Put the headrest poles (2) into the holes while pressing the release button (1).
3. Adjust the headrest to the appropriate height.



### Adjusting the height up and down

To raise the headrest:

1. Pull it up to the desired position (1).

To lower the headrest:

1. Push and hold the release button (2) on the headrest support.
2. Lower the headrest to the desired position (3).

## Seat warmers

### Front seat warmers (if equipped)

Seat warmers are provided to warm the seats during cold weather.

#### **⚠ WARNING**

The seat warmers can cause a **SERIOUS BURN**, even at low temperatures and especially if used for long periods of time.

Passengers must be able to feel if the seat is becoming too warm so they can turn it off, if needed.

People who cannot detect temperature change or pain to the skin should use extreme caution, especially the following types of passengers:

- Infants, children, elderly or disabled persons, or hospital outpatients.
- People with sensitive skin or who burn easily.
- Fatigued individuals.
- Intoxicated individuals.

(Continued)

(Continued)

- People taking medication that can cause drowsiness or sleepiness.

#### **⚠ WARNING**

**NEVER** place anything on the seat that insulates against heat when the seat warmer is in operation, such as a blanket or seat cushion. This may cause the seat warmer to overheat, causing a burn or damage to the seat.

#### **NOTICE**

To prevent damage to the seat warmers and seats:

- Never use a solvent such as paint thinner, benzene, alcohol or gasoline to clean the seats.
- Do not place heavy or sharp objects on seats equipped with seat warmers.
- Do not change the seat cover. It may damage the seat warmer.



OPDEN037015

While the engine is running, push either of the switches to warm the driver's seat or front passenger's seat.

During mild weather or under conditions where the operation of the seat warmer is not needed, keep the switches in the OFF position.

- Each time you push the switch, the temperature setting of the seat is changed as follows :

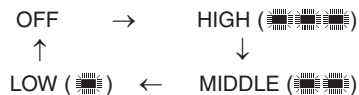

- When pressing the switch for more than 1.5 seconds with the seat warmer operating, the seat warmer will turn OFF.
- The seat warmer defaults to the OFF position whenever the ignition switch is placed to the ON position.

### **i** Information

**With the seat warmer switch in the ON position, the heating system in the seat turns off or on automatically depending on the seat temperature.**

## SEAT BELTS

This section describes how to use the seat belts properly. It also describes some of the things not to do when using seat belts.

### Seat belt safety precautions

Always fasten your seat belt and make sure all passengers have fastened their seat belts before starting any trip. Air bags are designed to supplement the seat belt as an additional safety device, but they are not a substitute. Most countries require all occupants of a vehicle to wear seat belts.

### WARNING

**Seat belts must be used by ALL passengers whenever the vehicle is moving. Take the following precautions when adjusting and wearing seat belts:**

- **Children under the age of 13 should be properly restrained in the rear seats.**
- **Never allow children to ride in the front passenger seat, unless the air bag is deactivated. If a child is seated in the front passenger seat, move the seat as far back as possible and properly restrain them in the seat.**
- **NEVER allow an infant or child to be carried on an occupant's lap.**
- **NEVER ride with the seatback reclined when the vehicle is moving.**
- **Do not allow children to share a seat or seat belt.**

(Continued)

(Continued)

- **Do not wear the shoulder belt under your arm or behind your back.**
- **Never wear a seat belt over fragile objects. If there is a sudden stop or impact, the seat belt can damage it.**
- **Do not use the seat belt if it is twisted. A twisted seat belt will not protect you properly in an accident.**
- **Do not use a seat belt if the webbing or hardware is damaged.**
- **Do not latch the seat belt into the buckles of other seats.**
- **NEVER unfasten the seat belt while driving. This may cause loss of vehicle control resulting in an accident.**
- **Make sure there is nothing in the buckle interfering with the seat belt latch mechanism. This may prevent the seat belt from fastening securely.**

(Continued)



(Continued)

- No modifications or additions should be made by the user which will either prevent the seat belt adjusting devices from operating to remove slack, or prevent the seat belt assembly from being adjusted to remove slack.

### WARNING

Damaged seat belts and seat belt assemblies will not operate properly. Always replace:

- Frayed, contaminated, or damaged webbing.
- Damaged hardware.
- The entire seat belt assembly after it has been worn in an accident, even if damage to webbing or assembly is not apparent.

## Seat belt warning light

### Seat belt warning

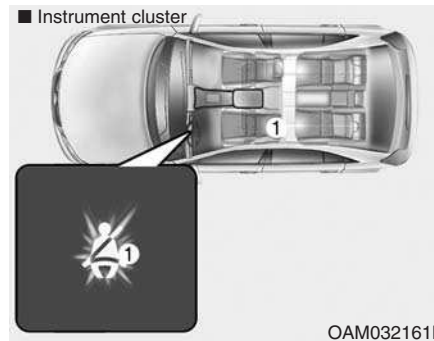

#### Driver's seat belt warning

As a reminder to the driver, the seat belt warning light will illuminate for approximately 6 seconds each time you turn the ignition switch ON regardless of belt fastening.

If the seat belt is not fastened when the ignition switch is turned ON or if it is disconnected after the ignition switch is turned ON, the seat belt warning light will illuminate until the belt is fastened.

If you start to drive without the seat belt fastened or you unfasten the seat belt when you drive under 20km/h, the corresponding warning light will continue to illuminate until you fasten the seat belt.

If you continue to drive without the seat belt fastened or you unfasten the seat belt when you drive over 20km/h, the seat belt warning chime will sound for approximately 100 seconds and the corresponding warning light will blink.

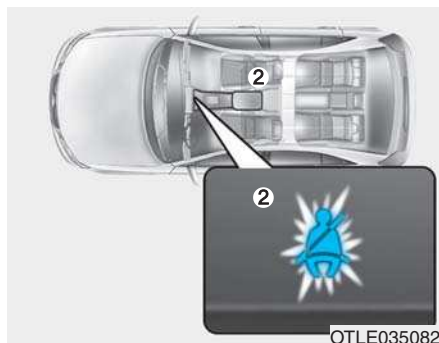

### Front passenger's seat belt warning

As a reminder to the front passenger, the front passenger's seat belt warning lights will illuminate for approximately 6 seconds each time you turn the ignition switch ON regardless of belt fastening.

If the seat belt is not fastened when the ignition switch is turned ON or if it is disconnected after the ignition switch is turned ON, the seat belt warning light will illuminate until the belt is fastened.

If you start to drive without the seat belt fastened or you unfasten the seat belt when you drive under 20km/h, the corresponding warning light will continue to illuminate until you fasten the seat belt.

If you continue to drive without the seat belt fastened or you unfasten the seat belt when you drive over 20km/h, the seat belt warning chime will sound for approximately 100 seconds and the corresponding warning light will blink.

### WARNING

**Riding in an improper position adversely affects the front passenger's seat belt warning system. It is important for the driver to instruct the passenger to properly be seated as instructed in this manual.**

### Information

- You can find the front passenger's seat belt warning light on the center fascia panel.
- Although the front passenger seat is not occupied, the seat belt warning light will blink or illuminate for 6 seconds.
- The front passenger's seat belt warning may operate when luggage is placed on the front passenger seat.

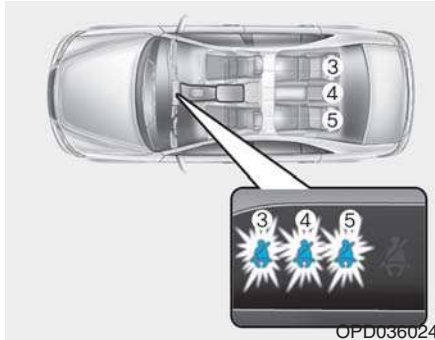

OPD036024

### Rear passenger's seat belt warning

As a reminder to the rear passengers, the rear passenger's seat belt warning lights will illuminate for approximately 6 seconds each time you turn the ignition switch ON regardless of belt fastening.

And then, the rear corresponding seat belt warning light will illuminate for approximately 35 seconds, if any of the following occurs:

- You drive over 9km/h when the rear seat belt is not fastened.
- The rear seat belt is disconnected when driving under 20km/h.

If the rear seat belt is fastened, the warning light will turn off immediately. If the rear seat belt is disconnected when you drive over the 20km/h, the corresponding seat belt warning light will blink and warning chime will sound for 35 seconds.

But, if the rear passenger's lap/shoulder belt is/are connected and disconnected twice within 9 seconds after the belt is fastened, the corresponding seat belt warning light will not operate.

## Seat belt restraint system

### Lap/shoulder belt

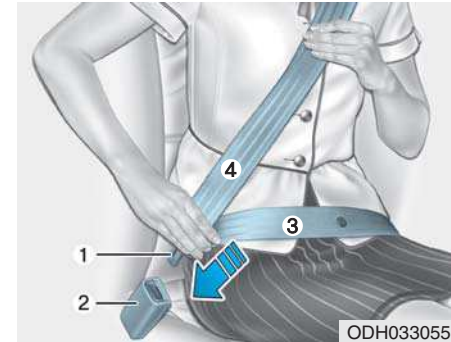

ODH033055

### To fasten your seat belt:

Pull it out of the retractor and insert the metal tab (1) into the buckle (2). There will be an audible "click" when the tab locks into the buckle.

You should place the lap belt (3) portion across your hips and the shoulder belt (4) portion across your chest.

The seat belt automatically adjusts to the proper length after the lap belt portion is adjusted manually so that it fits snugly around your hips. If you lean forward in a slow, easy motion, the belt will extend and move with you.

If there is a sudden stop or impact, the belt will lock into position. It will also lock if you try to lean forward too quickly.

### NOTICE

If you are not able to smoothly pull enough of the seat belt out from the retractor, firmly pull the seat belt out and release it. After release, you will be able to pull the belt out smoothly.

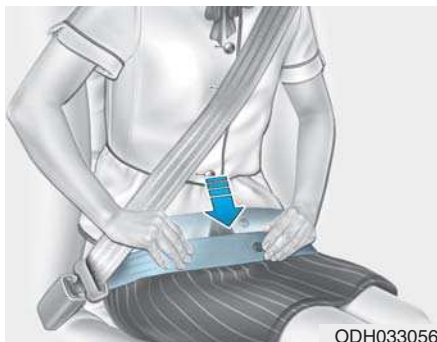

### ⚠ WARNING

**Improperly positioned seat belts may increase the risk of serious injury in an accident. Take the following precautions when adjusting the seat belt:**

- **Position the lap portion of the seat belt as low as possible across your hips, not on your waist, so that it fits snugly. This allows your strong pelvic bones to absorb the force of the crash, reducing the chance of internal injuries.**

(Continued)

### (Continued)

- **Position one arm under the shoulder belt and the other over the belt, as shown in the illustration.**
- **Always position the shoulder belt anchor into the locked position at the appropriate height.**
- **Never position the shoulder belt across your neck or face.**

### Height adjustment

You can adjust the height of the shoulder belt anchor to one of the four different positions for maximum comfort and safety.

The shoulder portion should be adjusted so it lies across your chest and midway over your shoulder nearest the door, not over your neck.

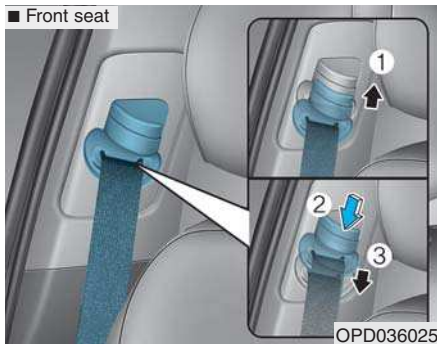

To adjust the height of the seat belt anchor, lower or raise the height adjuster into an appropriate position.

To raise the height adjuster, pull it up (1). To lower it, push it down (3) while pressing the height adjuster button (2).

Release the button to lock the anchor into position. Try sliding the height adjuster to make sure that it has locked into position.

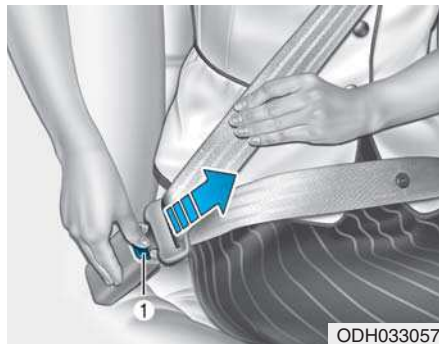

**To release your seat belt:**

Press the release button (1) in the locking buckle.

When it is released, the belt should automatically draw back into the retractor. If this does not happen, check the belt to be sure it is not twisted, then try again.

**Rear center seatbelt  
(3-point rear center seat belt)**

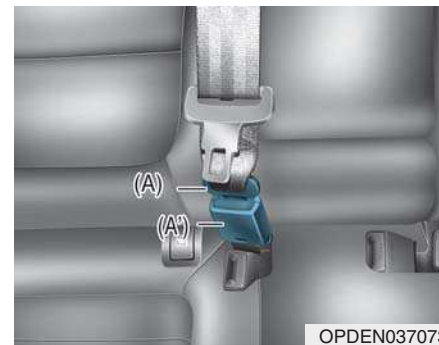

1. Insert the tongue plate (A) into the buckle (A') until an audible "click" is heard, indicating the latch is locked. Make sure the belt is not twisted.

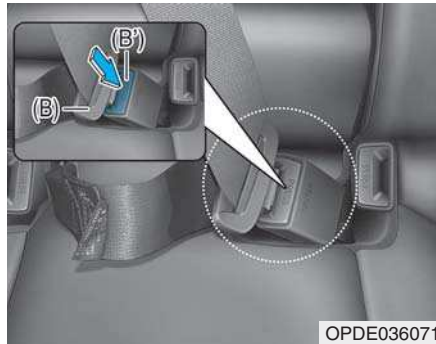

2. Pull the tongue plate (B) and insert it into the buckle (B') until an audible “click” is heard, indicating the latch is locked. Make sure the belt is not twisted.

When using the rear center seat belt, the buckle with the “CENTER” mark must be used.

### **WARNING**

**Always have the metal tab (A) inserted into the buckle (A').**

### **Information**

**If you are not able to pull out the safety belt from the retractor, firmly pull the belt out and release it. After release, you will be able to pull the belt out smoothly.**

### **Pre-tensioner seat belt**



Your vehicle is equipped with driver's and front passenger's and rear passengers (if equipped) Pre-tensioner Seat Belts (Retractor Pretensioner). The purpose of the pre-tensioner is to make sure the seat belts fit tightly against the occupant's body in certain frontal or side collision(s). The pre-tensioner seat belts may be activated in crashes where the frontal or side collision(s) is severe enough, together with the air bags.

When the vehicle stops suddenly, or if the occupant tries to lean forward too quickly, the seat belt retractor will lock into position. In certain frontal collisions, the pre-tensioner will activate and pull the seat belt into tighter contact against the occupant's body.

If the system senses excessive tension on the driver or passenger's seat belt when the pre-tensioner system activates, the load limiter inside the retractor pre-tensioner will release some of the pressure on the affected seat belt.

### WARNING

- **Always wear your seat belt and sit properly in your seat.**
- **Do not use the seat belt if it is loose or twisted. A loose or twisted seat belt will not protect you properly in an accident.**
- **Do not place anything near the buckle. This may adversely affect the buckle and cause it to function improperly.**
- **Always replace your pre-tensioners after activation or an accident.**
- **NEVER inspect, service, repair or replace the pre-tensioners yourself. This must be done by an authorized HYUNDAI dealer.**
- **Do not hit the seat belt assemblies.**

### WARNING

**Do not touch the pre-tensioner seat belt assemblies for several minutes after they have been activated. When the pre-tensioner seat belt mechanism deploys during a collision, the pre-tensioner can become hot and can burn you.**

### CAUTION

**Body work on the front area of the vehicle may damage the pre-tensioner seat belt system. Therefore, we recommend the system to be serviced by an authorized HYUNDAI dealer.**

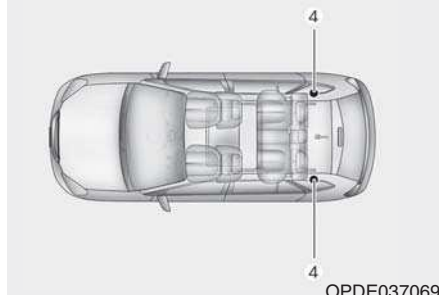
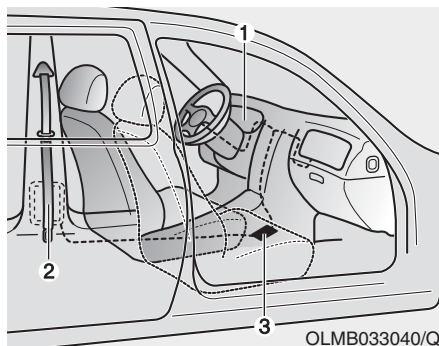

The Pre-Tensioner Seat Belt System consists mainly of the following components. Their locations are shown in the illustration above:

- (1) SRS air bag warning light
- (2) Retractor pre-tensioner

- (3) SRS control module
- (4) Rear Retractor pre-tensioner (if equipped)

### NOTICE

The sensor that activates the SRS control module is connected with the pre-tensioner seat belts. The SRS air bag warning light on the instrument cluster will illuminate for approximately 6 seconds after the ignition switch is placed in the ON position, and then it should turn off.

If the pre-tensioner is not working properly, the warning light will illuminate even if the SRS air bag is not malfunctioning. If the warning light does not illuminate, stays illuminated or illuminates when the vehicle is being driven, we recommend the pre-tensioner seat belts and/or SRS control module be inspected by an authorized HYUNDAI dealer as soon as possible.

### **i** Information

- Both the driver's and front passenger's pre-tensioner seat belts may be activated in certain frontal or side collisions.
- When the pre-tensioner seat belts are activated, a loud noise may be heard and fine dust, which may appear to be smoke, may be visible in the passenger compartment. These are normal operating conditions and are not hazardous.
- Although it is non-toxic, the fine dust may cause skin irritation and should not be inhaled for prolonged periods. Wash all exposed skin areas thoroughly after an accident in which the pre-tensioner seat belts were activated.



## Additional seat belt safety precautions

### *Seat belt use during pregnancy*

The seat belt should always be used during pregnancy. The best way to protect your unborn child is to protect yourself by always wearing the seat belt.

Pregnant women should always wear a lap-shoulder seat belt. Place the shoulder belt across your chest, routed between your breasts and away from your neck. Place the lap belt below your belly so that it fits **SNUGLY** across your hips and pelvic bone, under the rounded part of the belly.

#### **WARNING**

**To reduce the risk of serious injury or death to an unborn child during an accident, pregnant women should NEVER place the lap portion of the seat belt above or over the area of the abdomen where the unborn child is located.**

### *Seat belt use and children*

#### *Infant and small children*

Most countries have Child Restraint System laws which require children to travel in approved Child Restraint System devices, including booster seats. The age at which seat belts can be used instead of Child Restraint System differs among countries, so you should be aware of the specific requirements in your country, and where you are travelling. Infant and Child Restraint System must be properly placed and installed in a rear seat.

For more information refer to the “Child Restraint Systems” in this chapter.

#### **WARNING**

**ALWAYS properly restrain infants and small children in a Child Restraint System appropriate for the child’s height and weight.**

**To reduce the risk of serious injury or death to a child and other passengers, NEVER hold a child in your lap or arms when the vehicle is moving. The violent forces created during an accident will tear the child from your arms and throw the child against the interior of the vehicle.**

Small children are best protected from injury in an accident when properly restrained in the rear seat by a Child Restraint System that meets the requirements of the Safety Standards of your country. Before buying any Child Restraint System, make sure that it has a label certifying that it meets Safety Standard of your country. The Child Restraint System must be appropriate for your child's height and weight. Check the label on the Child Restraint System for this information. Refer to "Child Restraint Systems" in this chapter.

### Larger children

Children under age 13 and who are too large for a booster seat should always occupy the rear seat and use the available lap/shoulder belts. A seat belt should lie across the upper thighs and be snug across the shoulder and chest to restrain the child safely. Check belt fit periodically. A child's squirming could put the belt out of position. In the event of an accident, children are afforded the best safety restrained by a proper Child Restraint System in the rear seats.

If a larger child over age 13 must be seated in the front seat, the child must be securely restrained by the available lap/shoulder belt and the seat should be placed in the rear-most position.

If the shoulder belt portion slightly touches the child's neck or face, try placing the child closer to the center of the vehicle. If the shoulder belt still touches their face or neck, they need to be returned to an appropriate booster seat in the rear seat.

### WARNING

- **Always make sure larger children's seat belts are worn and properly adjusted.**
- **NEVER allow the shoulder belt to contact the child's neck or face.**
- **Do not allow more than one child to use a single seat belt.**

### ***Seat belt use and injured people***

A seat belt should be used when an injured person is being transported. Consult a physician for specific recommendations.

### ***One person per belt***

Two people (including children) should never attempt to use a single seat belt. This could increase the severity of injuries in case of an accident.

### ***Do not lie down***

Sitting in a reclined position when the vehicle is in motion can be dangerous. Even when buckled up, the protections of your restraint system (seat belts and/or air bags) is greatly reduced by reclining your seatback.

Seat belts must be snug against your hips and chest to work properly.

During an accident, you could be thrown into the seat belt, causing neck or other injuries.

The more the seat back is reclined, the greater the chance for the passenger's hips to slide under the lap belt or the passenger's neck to strike the shoulder belt.

#### **⚠ WARNING**

- **NEVER ride with a reclined seatback when the vehicle is moving.**
- **Riding with a reclined seatback increases your chance of serious or fatal injuries in the event of a collision or sudden stop.**
- **Driver and passengers should always sit well back in their seats, properly belted, and with the seatbacks upright.**

### **Care of seat belts**

Seat belt systems should never be disassembled or modified. In addition, care should be taken to assure that seat belts and belt hardware are not damaged by seat hinges, doors or other abuse.

#### ***Periodic inspection***

All seat belts should be inspected periodically for wear or damage of any kind. Any damaged parts should be replaced as soon as possible.

#### ***Keep belts clean and dry***

Seat belts should be kept clean and dry. If belts become dirty, they can be cleaned by using a mild soap solution and warm water. Bleach, dye, strong detergents or abrasives should not be used because they may damage and weaken the fabric.

### ***When to replace seat belts***

The entire seat belt assembly or assemblies should be replaced if the vehicle has been involved in an accident. This should be done even if no damage is visible. We recommend that you consult an authorized HYUNDAI dealer.

## **CHILD RESTRAINT SYSTEM (CRS)**

**Our recommendation:  
Children always in the rear**

### **⚠ WARNING**

**Always properly restrain children in the vehicle. Children of all ages are safer when riding in the rear seats. Never place a rearward-facing Child Restraint System on the front passenger seat, unless the air bag is deactivated.**

Children under age 13 should always ride in the rear seats and must always be properly restrained to minimize the risk of injury in an accident, sudden stop or sudden maneuver.

According to accident statistics, children are safer when properly restrained in the rear seats than in the front seat. Children too large for a Child Restraint System must use the seat belts provided.

Most countries have regulations which require children to travel in approved Child Restraint Systems.

The laws governing the age or height/weight restrictions at which seat belts can be used instead of Child Restraint System differs among countries, so you should be aware of the specific requirements in your country, and where you are travelling.

Child Restraint Systems must be properly installed in the vehicle seat. Always use a commercially available Child Restraint System that meets the requirements of your country.

### **Child Restraint System (CRS)**

Infants and younger children must be restrained in an appropriate rearward-facing or forward-facing CRS that has first been properly secured to the seat of the vehicle. Read and comply with the instructions for installation and use provided by the manufacturer of the Child Restraint System.

#### **⚠ WARNING**

- **Always follow the Child Restraint System manufacturer's instructions for installation and use.**
- **Always properly restrain your child in the Child Restraint System.**
- **Do not use an infant carrier or a child safety seat that "hooks" over a seatback, it may not provide adequate protection in an accident.**
- **After an accident, we recommend a HYUNDAI dealer to check the Child Restraint System, seat belts, ISOFIX anchorages and top-tether anchorages.**

### **Selecting a Child Restraint System (CRS)**

When selecting a Child Restraint System for your child, always:

- Make sure the Child Restraint System has a label certifying that it meets applicable Safety Standards of your country.

A Child Restraint System may only be installed if it was approved in accordance with the requirements of ECE-R44 or ECE-R129.

- Select a Child Restraint System based on your child's height and weight. The required label or the instructions for use typically provide this information.
- Select a Child Restraint System that fits the vehicle seating position where it will be used.
- Read and comply with the warnings and instructions for installation and use provided with the Child Restraint System.

### **Child Restraint System types**

There are three main types of Child Restraint Systems: rearward-facing, forward-facing and booster Child Restraint Systems.

They are classified according to the child's age, height and weight.

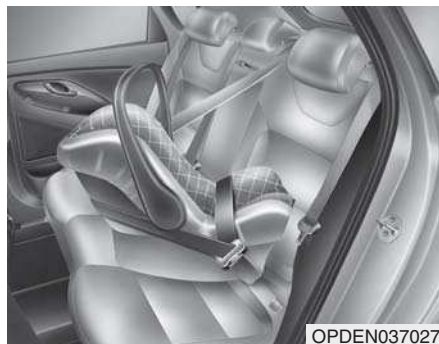

### Rearward-facing Child Restraint System

A rearward-facing Child Restraint System provides restraint with the seating surface against the back of the child. The harness system holds the child in place, and in an accident, acts to keep the child positioned in the Child Restraint Systems and reduce the stress to the fragile neck and spinal cord.

All children under the age of one year must always ride in a rearward-facing Child Restraint System. There are different types of rearward-facing Child Restraint Systems: infant-only Child Restraint Systems can only be used rearward-facing. Convertible and 3-in-1 Child Restraint Systems typically have higher height and weight limits for the rearward-facing position, allowing you to keep your child rearward-facing for a longer period of time.

Keep using Child Restraint Systems in the rearward-facing position as long as children fit within the height and weight limits allowed by the Child Restraint System's manufacturer.



### Forward-facing Child Restraint System

A forward-facing Child Restraint System provides restraint for the child's body with a harness. Keep children in a forward-facing Child Restraint System with a harness until they reach the top height or weight limit allowed by your Child Restraint System's manufacturer.

Once your child outgrows the forward-facing Child Restraint System, your child is ready for a booster seat.

### Booster seats

A booster seat is a Child Restraint System designed to improve the fit of the vehicle's seat belt system. A booster seat positions the seat belt so that it fits properly over the stronger parts of your child's body. Keep your children in booster seats until they are big enough to fit in a seat belt properly.

For a seat belt to fit properly, the lap belt must lie comfortable across the upper thighs, not the stomach. The shoulder belt should lie comfortable across the shoulder and chest and not across the neck or face. Children under age 13 must always be properly restrained to minimize the risk of injury in an accident, sudden stop or sudden maneuver.

### Installing a Child Restraint System (CRS)

#### WARNING

**Before installing your Child Restraint System always:**

**Read and follow the instructions provided by the manufacturer of the Child Restraint System.**

**Failure to follow all warnings and instructions could increase the risk of the SERIOUS INJURY or DEATH if an accident occurs.**

#### WARNING

**If the vehicle headrest prevents proper installation of a Child Restraint System, the headrest of the respective seating position shall be readjusted or entirely removed.**

After selecting a proper Child Restraint System for your child and checking that the Child Restraint System fits properly on the seating position, there are three general steps for a proper installation:

- **Properly secure the Child Restraint System to the vehicle.** All Child Restraint Systems must be secured to the vehicle with the lap belt or lap part of a lap/shoulder belt or with the ISOFIX top-tether and/or ISOFIX anchorage and/or with the support leg.
- **Make sure the Child Restraint System is firmly secured.** After installing a Child Restraint System to the vehicle, push and pull the seat forward and from side-to-side to verify that it is securely attached to the seat. A Child Restraint System secured with a seat belt should be installed as firmly as possible. However, some side-to-side movement can be expected.

When installing a Child Restraint System, adjust the vehicle seat and seatback (up and down, forward and rearward) so that your child fits in the Child Restraint System in a comfortable manner.

- **Secure the child in the Child Restraint System.** Make sure the child is properly strapped in the Child Restraint System according to the Child Restraint System manufacturer's instructions.

### CAUTION

**A Child Restraint System in a closed vehicle can become very hot. To prevent burns, check the seating surface and buckles before placing your child in the Child Restraint System.**

### ***ISOFIX anchorage and top-tether anchorage (ISOFIX anchorage system) for children***

The ISOFIX system holds a Child Restraint System during driving and in an accident. This system is designed to make installation of the Child Restraint System easier and reduce the possibility of improperly installing your Child Restraint System. The ISOFIX system uses anchors in the vehicle and attachments on the Child Restraint System. The ISOFIX system eliminates the need to use seat belts to secure the Child Restraint System to the rear seats.

ISOFIX anchorages are metal bars built into the vehicle. There are two lower anchors for each ISOFIX seating position that will accommodate a Child Restraint System with lower attachments.

To use the ISOFIX system in your vehicle, you must have a Child Restraint System with ISOFIX attachments.

The Child Restraint System manufacturer will provide you with instructions on how to use the Child Restraint System with its attachments for the ISOFIX anchorages.

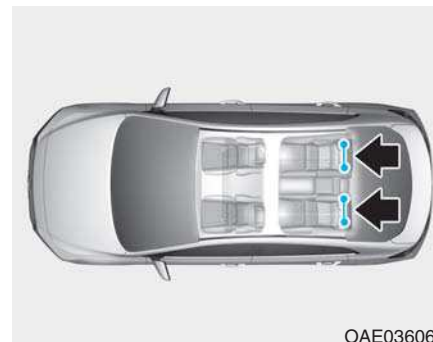

OAE036063

ISOFIX anchorages have been provided in the left and right outboard rear seating positions. Their locations are shown in the illustration.

### WARNING

**Do not attempt to install a Child Restraint System using ISOFIX anchorages in the rear center seating position. There are no ISOFIX anchorages provided for this seat. Using the outboard seat anchorages, for the CRS installation on the rear center seating position, can damage the anchorages.**



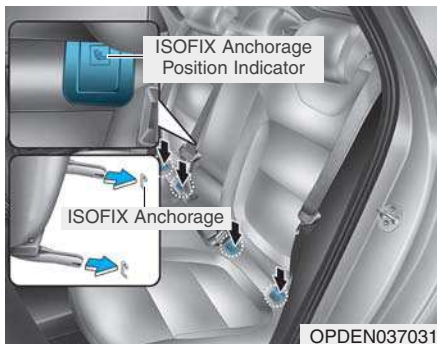

ISOFIX anchorages are located between the seatback and the seat cushion of the rear seat left and right outboard seating positions, indicated by the symbols .

To use the ISOFIX anchorages, push the upper portion of the ISOFIX anchorage cover.

### **Securing a Child Restraint System with the “ISOFIX Anchorage System”**

To install an i-Size or ISOFIX-compatible Child Restraint System in either of the rear outboard seating positions:

1. Move the seat belt buckle away from the ISOFIX anchorages.
2. Move any other objects away from the anchorages that could prevent a secure connection between the Child Restraint System and the ISOFIX anchorages.
3. Place the Child Restraint System on the vehicle seat, then attach the seat to the ISOFIX anchorages according to the instructions provided by the Child Restraint System manufacturer.
4. Follow the instructions of the Child Restraint System's manufacturer for proper installation and connection of the ISOFIX attachments on the Child Restraint System to the ISOFIX anchorages.

### **⚠ WARNING**

**Take the following precautions when using the ISOFIX system:**

- **Read and follow all installation instructions provided with your Child Restraint System.**
- **To prevent the child from reaching and taking hold of unretracted seat belts, buckle all unused rear seat belts and retract the seat belt webbing behind the child. Children can be strangled if a shoulder belt becomes wrapped around their neck and the seat belt tightens.**
- **NEVER attach more than one Child Restraint System to a single anchorage. This could cause the anchor or attachment to come loose or break.**
- **Always have the ISOFIX system inspected by your dealer after an accident. An accident can damage the ISOFIX system and may not properly secure the Child Restraint System.**

### Securing a Child Restraint System seat with “Top-tether Anchorage” system



Top-tether anchorages for Child Restraint Systems are located on the rear of the seatbacks.



1. Route the Child Restraint System top-tether strap over the seatback. Placing the top tether strap, please follow the instructions of the Child Restraint System manufacturer.
2. Connect the top-tether strap to the top-tether anchorage, then tighten the top-tether strap according to the instructions of your Child Restraint System's manufacturer to firmly attach the Child Restraint System to the seat.

### WARNING

Take the following precautions when installing the top-tether:

- Read and follow all installation instructions provided with your Child Restraint System.
- NEVER attach more than one Child Restraint System to a single ISOFIX top-tether anchorage. This could cause the anchorage or attachment to come loose or break.
- Do not attach the top-tether to anything other than the correct top-tether anchorage. It may not work properly if attached to something else.
- Child Restraint System anchorages are designed to withstand only those loads imposed by correctly fitted Child Restraint System.

Under no circumstances are they to be used for adult seat belts or harnesses or for attaching other items or equipment to the vehicle.

### Suitability of each seating position for ISOFIX Child Restraint Systems according to ECE regulations

Mass Group	Size Class	Fixture	Vehicle ISOFIX positions			
			Front Passenger	2nd row		
				Left Hand	Center	Right Hand
Carrycot	F	ISO/L1	N/A	X	N/A	X
	G	ISO/L2	N/A	X	N/A	X
0 : UP TO 10KG	E	ISO/R1	N/A	IL	N/A	IL
0+ : UP TO 13KG	E	ISO/R1	N/A	IL	N/A	IL
	D	ISO/R2	N/A	IL	N/A	IL
	C	ISO/R3	N/A	IL	N/A	IL
1 : 9 TO 18KG	D	ISO/R2	N/A	IL	N/A	IL
	C	ISO/R3	N/A	IL	N/A	IL
	B	ISO/F2	N/A	IUF,IL	N/A	IUF,IL
	B1	ISO/F2X	N/A	IUF,IL	N/A	IUF,IL
	A	ISO/F3	N/A	IUF,IL	N/A	IUF,IL

IUF = suitable for ISOFIX forward child restraints systems of universal category approved for use in the mass group.

IL = suitable for particular ISOFIX child restraints systems (CRS) given in the attached list. These ISOFIX CRS are those of the "specific vehicle", "restricted" or "semi-universal" categories.

X = ISOFIX position not suitable for ISOFIX child restraint system in this mass group and/or this size class.

A - ISO/F3: Full-Height Forward-Facing toddler Child Restraint System (height 720mm)

B - ISO/F2: Reduced-Height Forward-Facing toddler Child Restraint System (height 650mm)

B1 - ISO/F2X: Reduced-Height Second Version Back Surface Shape Forward-Facing toddler Child Restraint System (height 650mm)

C - ISO/R3: Full-Size Rearward-Facing toddler Child Restraint System

D - ISO/R2: Reduced-Size Rearward-Facing toddler Child Restraint System

E - ISO/R1: Infant-Size Rearward-Facing Child Restraint System

F - ISO/L1: Left Lateral Facing position Child Restraint System (carry-cot)

G - ISO/L2: Right Lateral Facing position Child Restraint System (carry-cot)

### **Securing a Child Restraint System with a lap/shoulder belt**

When not using the ISOFIX system, all Child Restraint Systems must be secured to a rear seat with the lap part of a lap/shoulder belt.

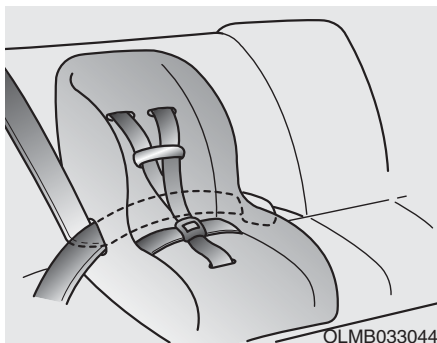

#### **Installing a Child Restraint System with a lap/shoulder belt**

To install a Child Restraint System on the rear seats, do the following:

1. Place the Child Restraint System on a rear seat and route the lap/shoulder belt around or through the Child Restraint System, following the Child Restraint System manufacturer's instructions. Make sure the seat belt webbing is not twisted.

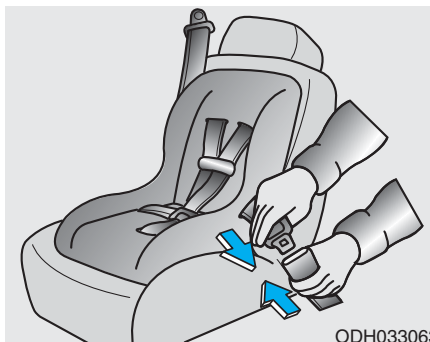

2. Fasten the lap/shoulder belt latch into the buckle. Listen for the distinct "click" sound.

#### ***i* Information**

**Position the release button so that it is easy to access in case of an emergency.**

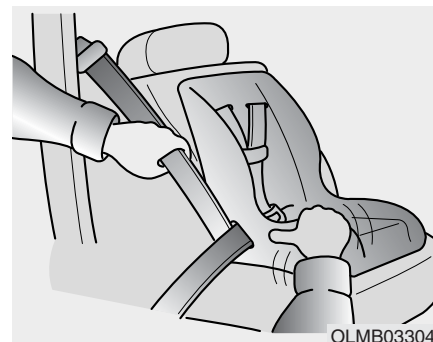

3. Remove as much slack from the belt as possible by pushing down on the Child Restraint System while feeding the shoulder belt back into the retractor.
4. Push and pull on the Child Restraint System to confirm that the seat belt is holding it firmly in place.

If your Child Restraint System manufacturer recommends the use of a top-tether with the lap/shoulder belt, see page 2-40.

To remove the Child Restraint System, press the release button on the buckle and then pull the lap/shoulder belt out of the Child Restraint System and allow the seat belt to retract fully.

### Suitability of each seating position for "universal" category belted Child Restraint Systems according to ECE regulations

Mass Group		Seating Position				
		Front Passenger		Second Row		
		Airbag activated	Airbag deactivated	Outboard Left	Center (3 POINT BELT)	Outboard Right
Group 0 (0-9months)	up to 10kg	X	U*	U	U**	U
Group 0 + (0-2years)	up to 13kg	X	U*	U	U**	U
Group I (9months-4years)	9 to 18kg	X	U*	U	U**	U
Group II (15 to 25kg)	15 to 25kg	UF	U*	U	U	U
Group III (22 to 36kg)	22 to 36kg	UF	U*	U	U	U

U = Suitable for "universal" category Child Restraint Systems approved for use in this mass group.

U\* = Suitable for "universal" category Child Restraint Systems approved for use in this mass group (When you install the child seat on Front Passenger seat, you should move the seat position to upward and the seat back position to forward properly, to restrain child seat.)

\* Height adjustable device of Front passenger seat is an optional feature.

U\*\* = Seating position not suitable for fitment of Child Restraint Systems with support leg.

UF = Suitable for forward facing "universal" category restraints approved for use in this mass group.

X = Seat position not suitable for children in this mass group.

#### WARNING

**We recommend that a child restraint seat be installed in the rear seat, even if the front passenger's air bag ON/OFF switch is set to the OFF position. To ensure the safety of your child, the front passenger's air bag must be deactivated when it should be necessary to install a child restraint seat on the front passenger seat in exceptional circumstances.**

***i-Size Child Restraint Systems according to ECE regulations***

Mass Group	Seating Position			
	Passenger Front	Second Row		
		Outboard Left	Center	Outboard Right
i-size Child Restraint Systems	X	i-U	X	i-U

i-U : Suitable for i-Size "universal" Child Restraint Systems forward and rearward-facing

i-UF : Suitable for forward-facing i-Size "universal" Child Restraint Systems only

X : Seat position not suitable for i-size Child Restraint Systems

***Recommended child restraint systems (for Europe)***

Mass Group	Name	Manufacturer	Type of Fixation	ECE-R44 Approval No.
Group 0+	Cabriofix & Familyfix	Maxi Cosi	Rearward-facing with ISOFIX	E4 04443907
Group I	Duo Plus	Britax Römer	Forward-facing with ISOFIX and top-tether	E1 04301133
Group II	KidFix II XP	Britax Römer	Forward-facing with ISOFIX and vehicle Belt	E1 04301323
Group III	Junior III	Graco	Forward-facing with vehicle Belt	E11 03.44.164 E11 03.44.165

CRS Manufacturer information

Maxi Cosi Cabriofix & Familyfix <http://www.maxi-cosi.com>

Britax Römer <http://www.britax.com>

Graco <http://www.gracobaby.com>

## AIR BAG – SUPPLEMENTAL RESTRAINT SYSTEM

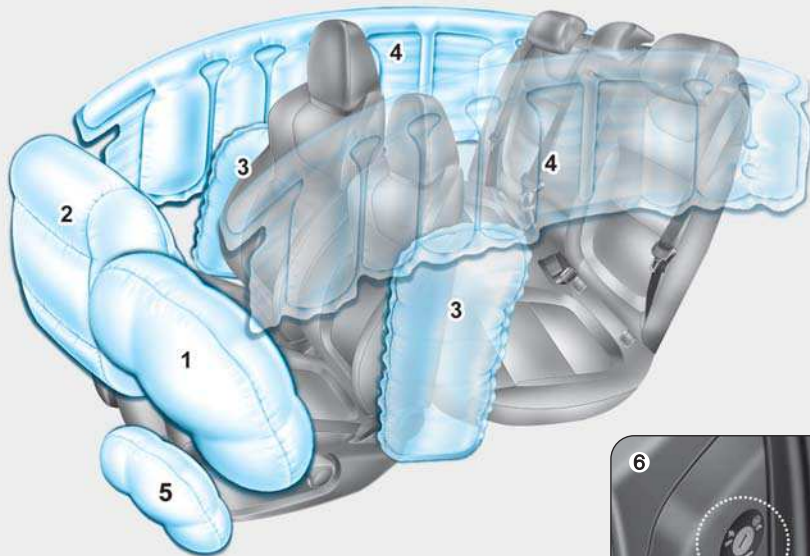

1. Driver's front air bag
  2. Passenger's front air bag
  3. Side air bag
  4. Curtain air bag
  5. Knee air bag\*
  6. Front passenger air bag ON/OFF switch
- \* : if equipped



The actual air bags in the vehicle may differ from the illustration.

OPDEN037032/OPDE036066

The vehicles are equipped with a Supplemental Air Bag System for the driver's seat and front passenger's seats.

The front air bags are designed to supplement the three-point seat belts. For these air bags to provide protection, the seat belts must be worn at all times when driving.

You can be severely injured or killed in an accident if you are not wearing a seat belt. Air bags are designed to supplement seat belts, but do not replace them. Also, air bags are not designed to deploy in every collision. In some accidents, the seat belts are the only restraint protecting you.

### **WARNING**

#### **AIR BAG SAFETY PRECAUTIONS**

**ALWAYS** use seat belts Child Restraint Systems - every trip, every time, everyone! Even with air bags, you can be seriously injured or killed in a collision if you are improperly belted or not wearing your seat belt when the air bag inflates.

**NEVER** place a child in any Child Restraint System or booster seat in the front passenger seat, unless the air bag is deactivated.

**An inflating air bag could forcefully strike the infant or child causing serious or fatal injuries.**

**ABC - Always Buckle Children under age 13 in the back seat. It is the safest place for children of any age to ride. If a child age 13 or older must be seated in the front seat, he or she must be properly belted and the seat should be moved as far back as possible.**

**All occupants should sit upright with the seatback in an upright position, centered on the seat cushion with their seat belt on, legs comfortably extended and their feet on the floor until the vehicle is parked and the engine is turned off. If an occupant is out of position during an accident, the rapidly deploying air bag may forcefully contact the occupant causing serious or fatal injuries.**

**You and your passengers should never sit or lean unnecessarily close to the air bags or lean against the door or center console.**

**Move your seat as far back as possible from front air bags, while still maintaining control of the vehicle.**



## Where are the air bags?

### Driver's and passenger's front air bags

■ Driver's front air bag



OPDEN037033

■ Driver's knee air bag

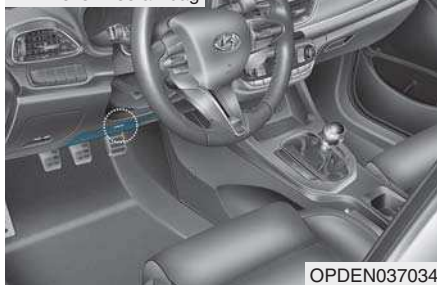

OPDEN037034

■ Passenger's front air bag



OPD036041

Your vehicle is equipped with a Supplemental Restraint System (SRS) and lap/shoulder belts at both the driver and passenger seating positions.

The SRS consists of air bags which are located in the center of the steering wheel, in the driver's side lower crash pad below the steering wheel, and the passenger's side front panel pad above the glove box.

The air bags are labeled with the letters "AIR BAG" embossed on the pad covers.

The purpose of the SRS is to provide the vehicle's driver and front passengers with additional protection than that offered by the seat belt system alone in case of a frontal impact of sufficient severity.

## ⚠ WARNING

To reduce the risk of serious injury or death from inflating front air bags, take the following precautions:

- Seat belts must be worn at all times to help keep occupants positioned properly.
- Move your seat as far back as possible from front air bags, while still maintaining control of the vehicle.
- Never lean against the door or center console.
- Do not allow the front passenger to place their feet or legs on the dashboard.

(Continued)

### (Continued)

- No objects (such as crash pad cover, cellular phone holder, cup holder, perfume or stickers) should be placed over or near the air bag modules on the steering wheel, instrument panel, windshield glass, and the front passenger's panel above the glove box. Such objects could cause harm if the vehicle is in a crash severe enough to cause the air bags to deploy.
- Do not attach any objects on the front windshield and inside mirror.



### Passenger's front air bag ON/OFF switch

The purpose of the switch is to disable the passenger's front air bag in order to transport occupants who are at increased risk for air bag-related injury due to age, size, or medical condition.



To deactivate the passenger's front air bag:

Insert the key or a similar rigid device into the passenger's front air bag ON/OFF switch and turn it to the OFF position. The passenger air bag OFF indicator (⊗) will illuminate and stay on until the passenger's front air bag is reactivated.



To reactivate the passenger's front air bag:

Insert the key or a similar rigid device into the passenger's front air bag ON/OFF switch and turn it to the ON position. The passenger air bag ON indicator (⊗) will illuminate and stay on for 60 seconds.

### **i** Information

The passenger's front air bag ON/OFF indicator illuminates for about 4 seconds after the ignition switch is placed in the ON position.

### **⚠** WARNING

Never allow an adult passenger to ride in the front passenger seat when the passenger air bag OFF indicator is illuminated. During a collision, the air bag will not inflate if the indicator is illuminated. Turn on the passenger's front air bag or have your passenger move to the rear seat.

### **⚠** WARNING

If the passenger's front air bag ON/OFF switch malfunctions, the following conditions may occur:

- The air bag warning light (⚠) on the instrument cluster will illuminate.
- The passenger air bag OFF indicator (⊗) will not illuminate and the ON indicator (⊗) will come on and go off after approximately 60 seconds. The passenger's front air bag will inflate in a frontal impact even though the passenger's front air bag ON/OFF switch is set to the OFF position.
- We recommend that an authorized HYUNDAI dealer inspect the passenger's front air bag ON/OFF switch and the SRS air bag system as soon as possible.

### Side air bags

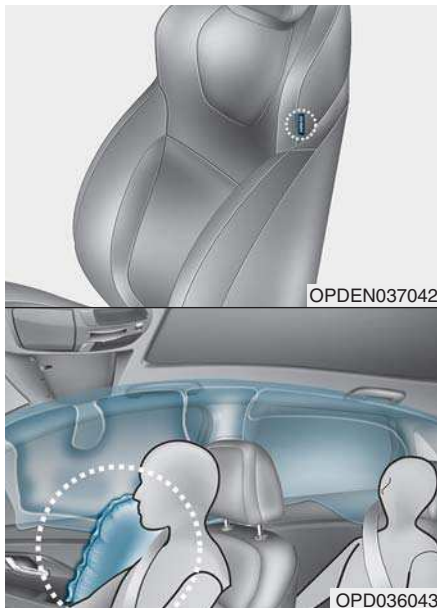

Your vehicle is equipped with a side air bag in each front seat. The purpose of the air bag is to provide the vehicle's driver and the front passenger with additional protection than that offered by the seat belt alone.

The side air bags are designed to deploy during certain side impact collisions, depending on the crash severity, angle, speed and point of impact.

The side air bags on both sides of the vehicle are designed to deploy when a rollover is detected by a rollover sensor. (if equipped with rollover sensor)

The side air bags are not designed to deploy in all side impact or rollover situations.

#### **⚠ WARNING**

**To reduce the risk of serious injury or death from an inflating side air bag, take the following precautions:**

- **Seat belts must be worn at all times to help keep occupants positioned properly.**
- **Do not allow passengers to lean their heads or bodies onto doors, put their arms on the doors, stretch their arms out of the window, or place objects between the doors and seats.**

**(Continued)**

**(Continued)**

- **Hold the steering wheel at the 9 o'clock and 3 o'clock positions, to minimize the risk of injuries to your hands and arms.**
- **Do not use any accessory seat covers. This could reduce or prevent the effectiveness of the system.**
- **Do not hang other objects except clothes. In an accident it may cause vehicle damage or personal injury especially when air bag is inflated.**
- **Do not place any objects over the air bag or between the air bag and yourself. Also, do not attach any objects around the area the air bag inflates such as the door, side door glass, front and rear pillar.**

**(Continued)**

(Continued)

- Do not place any objects between the door and the seat. They may become dangerous projectiles if the side air bag inflates.
- Do not install any accessories on the side or near the side air bags.
- Do not cause impact to the doors when the ignition switch is in the ON position as this may cause the side air bags to inflate.
- If the seat or seat cover is damaged, we recommend that the system be serviced by an authorized HYUNDAI dealer.

### Curtain air bags

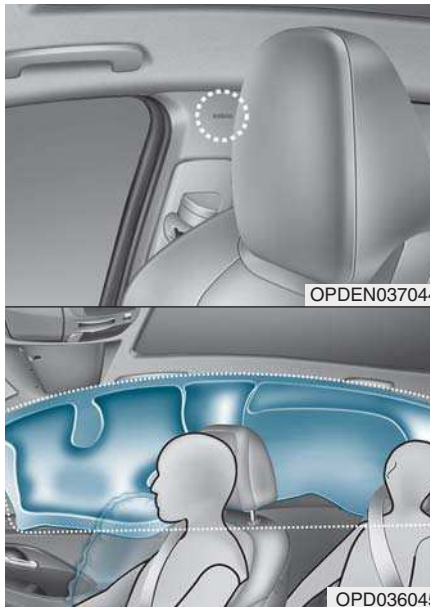

Curtain air bags are located along both sides of the roof rails above the front and rear doors.

They are designed to help protect the heads of the front seat occupants and the rear outboard seat occupants in certain side impact collisions.

The curtain air bags are designed to deploy during certain side impact collisions, depending on the crash severity, angle, speed and impact.

The curtain air bags on both sides of the vehicle are designed to deploy when a rollover is detected by a rollover sensor. (if equipped with rollover sensor)

The curtain air bags are not designed to deploy in all side impact or rollover situations.

#### WARNING

**To reduce the risk of serious injury or death from an inflating curtain air bag, take the following precautions:**

- All seat occupants must wear seat belts at all times to help keep occupants positioned properly.

(Continued)

### (Continued)

- Properly secure Child Restraint System as far away from the door as possible.
- Do not place any objects over the air bag. Also, do not attach any objects around the area the air bag inflates such as the door, side door glass, front and rear pillar, roof side rail.

- Do not hang other objects except clothes, especially hard or breakable objects.

In an accident, it may cause vehicle damage or personal injury.

- Do not allow passengers to lean their heads or bodies onto doors, put their arms on the doors, stretch their arms out of the window, or place objects between the doors and seats.
- Do not open or repair the side curtain air bags.

### How does the air bags system operate?

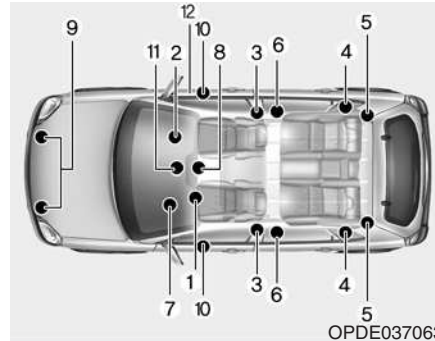

The SRS consists of the following components:

- (1) Driver's front air bag module/  
Driver's knee air bag module
- (2) Passenger's front air bag module
- (3) Side air bag modules/  
Side impact sensors
- (4) Curtain air bag modules
- (5) Rear Retractor pre-tensioner  
(if equipped)
- (6) Retractor pre-tensioner assemblies
- (7) Air bag warning light

- (8) SRS control module (SRSCM)/  
Rollover sensor
- (9) Front impact sensors
- (10) Side pressure sensors
- (11) Passenger's front air bag  
ON/OFF indicator  
(front passenger's seat only)
- (12) Passenger's front air bag  
ON/OFF switch

The SRSCM continually monitors all SRS components while the ignition switch is ON to determine if a crash impact is severe enough to require air bag deployment or pre-tensioner seat belt deployment.



### SRS warning light

The SRS (Supplement Restraint System) air bag warning light on the instrument panel displays the air bag symbol depicted in the illustration. The system checks the air bag electrical system for malfunctions. The light indicates that there is a potential problem with your air bag system, which could include your side and/or curtain air bags used for rollover protection (if equipped with rollover sensor).

### WARNING

**If your SRS malfunctions, the air bag may not inflate properly during an accident increasing the risk of serious injury or death.**

**If any of the following conditions occur, your SRS is malfunctioning:**

- **The light does not turn on for approximately six seconds when the ignition switch is in the ON position.**
- **The light stays on after illuminating for approximately six seconds.**
- **The light comes on while the vehicle is in motion.**
- **The light blinks when the engine is running.**

**We recommend that an authorized HYUNDAI dealer inspect the SRS as soon as possible if any of these conditions occur.**

During a moderate to severe frontal collision, sensors will detect the vehicle's rapid deceleration. If the rate of deceleration is high enough, the control unit will inflate the front air bags, at the time and with the force needed.

The front air bags help protect the driver and front passenger by responding to frontal impacts in which seat belts alone cannot provide adequate restraint. When needed, the side air bags help provide protection in the event of a side impact or rollover by supporting the side upper body area.

- Air bags are activated (able to inflate if necessary) only when the ignition switch is in the ON position.
- Air bags inflate in the event of certain frontal or side collisions to help protect the occupants from serious physical injury.
- There is no single speed at which the air bags will inflate. Generally, air bags are designed to inflate based upon the severity of a collision and its direction. These two factors determine whether the sensors produce an electronic deployment/inflation signal.

- Air bag deployment depends on a number of factors including vehicle speed, angles of impact and the density and stiffness of the vehicles or objects which your vehicle impacts during a collision. The determining factors are not limited to those mentioned above.
- The front air bags will completely inflate and deflate in an instant. It is virtually impossible for you to see the air bags inflate during an accident. It is much more likely that you will simply see the deflated air bags hanging out of their storage compartments after the collision.
- In addition to inflating in serious side collisions, vehicles equipped with a rollover sensor, side and/or curtain air bags will inflate if the sensing system detects a rollover. When a rollover is detected, curtain air bags will remain inflated longer to help provide protection from ejection, especially when used in conjunction with the seat belts. (if equipped with a rollover sensor)
- To help provide protection, the air bags must inflate rapidly. The speed of air bag inflation is a consequence of extremely short time in which to inflate the air bag between the occupant and the vehicle structures before the occupant impacts those structures. This speed of inflation reduces the risk of serious or life-threatening injuries and is thus a necessary part of air bag design. However, the rapid air bag inflation can also cause injuries which can include facial abrasions, bruises and broken bones because the inflation speed also causes the air bags to expand with a great deal of force.
- There are even circumstances under which contact with the air bag can cause fatal injuries, especially if the occupant is positioned excessively close to the air bag.

You can take steps to reduce the risk of being injured by an inflating air bag. The greatest risk is sitting too close to the air bag. An air bag needs space to inflate. It is recommended that drivers sit as far as possible between the center of the steering wheel and the chest while still maintaining control of the vehicle.



■ Driver's front air bag (1)



When the SRSCM detects a sufficiently severe impact to the front of the vehicle, it will automatically deploy the front air bags.

■ Driver's front air bag (2)



Upon deployment, tear seams molded directly into the pad covers will separate under pressure from the expansion of the air bags. Further opening of the covers allows full inflation of the air bags.

A fully inflated air bag, in combination with a properly worn seat belt, slows the driver's or the front passenger's forward motion, reducing the risk of head and chest injury.

■ Driver's front air bag (3)



■ Passenger's front air bag



After complete inflation, the air bag immediately starts deflating, enabling the driver to maintain forward visibility and the ability to steer or operate other controls.

 **WARNING**

To prevent objects from becoming dangerous projectiles when the passenger's air bag inflates:

- Do not install or place any objects (drink holder, CD holder, stickers, etc.) on the front passenger's panel above the glove box where the passenger's air bag is located.
- Do not install a container of liquid air freshener near the instrument cluster or on the instrument panel surface.

**What to expect after an air bag inflates**

After a frontal or side air bag inflates, it will deflate very quickly. Air bag inflation will not prevent the driver from seeing out of the windshield or being able to steer. Curtain air bags may remain partially inflated for some time after they deploy.

 **WARNING**

After an air bag inflates, take the following precautions:

- Open your windows and doors as soon as possible after impact to reduce prolonged exposure to the smoke and powder released by the inflating air bag.
- Do not touch the air bag storage area's internal components immediately after an air bag has inflated. The parts that come into contact with an inflating air bag may be very hot.
- Always wash exposed skin areas thoroughly with cold water and mild soap.
- We recommend that an authorized HYUNDAI dealer replace the air bag immediately after deployment. Air bags are designed to be used only once.

**Noise and smoke from inflating air bag**

When the air bags inflate, they make a loud noise and may produce smoke and powder in the air inside of the vehicle. This is normal and is a result of the ignition of the air bag inflator. After the air bag inflates, you may feel substantial discomfort in breathing because of the contact of your chest with both the seat belt and the air bag, as well as from breathing the smoke and powder. The powder may aggravate asthma for some people. If you experience breathing problems after an air bag deployment, seek medical attention immediately.

Though the smoke and powder are nontoxic, they may cause irritation to the skin, eyes, nose, throat, etc. If this is the case, wash and rinse with cold water immediately and seek medical attention if the symptoms persist.

**Do not install a Child Restraint System on the front passenger seat**



OYDESA2042

Never install a Child Restraint System in the front passenger seat, unless the air bag is deactivated

**⚠ WARNING**

**NEVER** use a rearward facing Child Restraint on a seat protected by an ACTIVE AIRBAG in front of it, **DEATH** or **SERIOUS INJURY** to the **CHILD** can occur.

**Why didn't my air bag go off in a collision?**

There are certain types of accidents in which the air bag would not be expected to provide additional protection. These include rear impacts, second or third collisions in multiple impact accidents, as well as low speed impacts. Damage to the vehicle indicates a collision energy absorption, and is not an indicator of whether or not an air bag should have inflated.

**Air bag collision sensors**

**⚠ WARNING**

**To reduce the risk of an air bag deploying unexpectedly and causing serious injury or death:**

- Do not hit or allow any objects to impact the locations where air bags or sensors are installed.

**(Continued)**

**(Continued)**

- Do not perform maintenance on or around the air bag sensors. If the location or angle of the sensors is altered, the air bags may deploy when they should not or may not deploy when they should.
- Do not install bumper guards or replace the bumper with a non-genuine part. This may adversely affect the collision and air bag deployment performance.
- Place the ignition switch to the **LOCK/OFF** or **ACC** position, when the vehicle is being towed to prevent inadvertent air bag deployment.
- We recommend that all air bag repairs are conducted by an authorized **HYUNDAI** dealer.

## Safety system of your vehicle

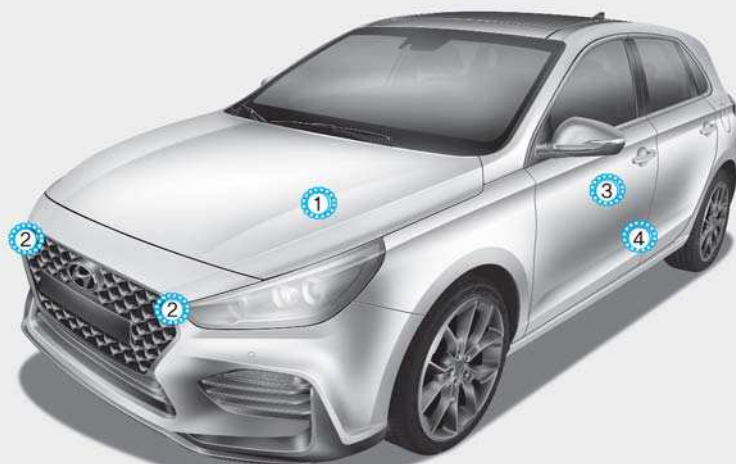

1. SRS control module
  2. Front impact sensor
  3. Side pressure sensor (front)\*
  4. Side impact sensor (rear)\*
- \* : if equipped

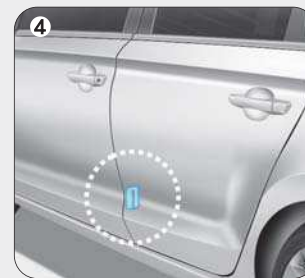

OPDEN037046/OPDEN037047/OPDEN037048/OPD036049/OPD036050

## Air bag inflation conditions

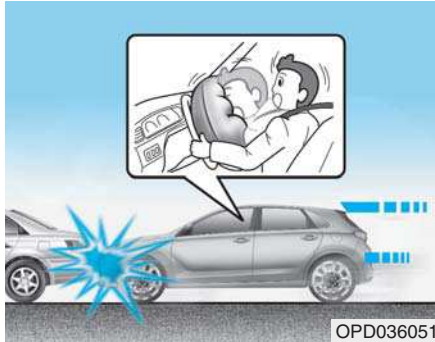

### Front air bags

Front air bags are designed to inflate in a frontal collision depending on the severity, speed or angles of impact of the front collision.

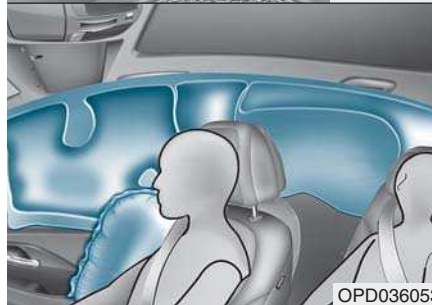
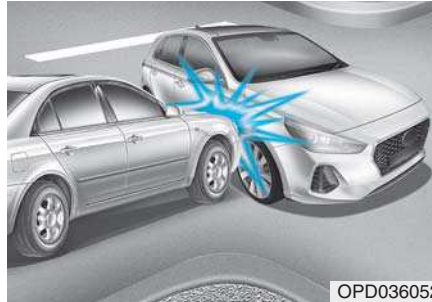

### Side and curtain air bags

Side and curtain air bags are designed to inflate when an impact is detected by side collision sensors depending on the severity, speed or angles of impact resulting from a side impact collision.

Although the driver's and front passenger's air bags are designed to inflate in frontal collisions, they also may inflate in other types of collisions if the front impact sensors detect a sufficient impact. Side and curtain air bags are designed to inflate in side impact collisions, but they may inflate in other collisions if the side impact sensors detect a sufficient impact.

Also, the side and curtain air bags are designed to inflate when a rollover is detected by a rollover sensor. (if equipped with rollover sensor)

If the vehicle chassis is impacted by bumps or objects on unimproved roads, the air bags may deploy. Drive carefully on unimproved roads or on surfaces not designed for vehicle traffic to prevent unintended air bag deployment.

### Air bag non-inflation conditions



In certain low-speed collisions the air bags may not deploy. The air bags are designed not to deploy in such cases because they may not provide benefits beyond the protection of the seat belts.



Front air bags are not designed to inflate in rear collisions, because occupants are moved backward by the force of the impact. In this case, inflated air bags would not provide any additional benefit.



Front air bags may not inflate in side impact collisions, because occupants move in the direction of the collision, and thus in side impacts, front air bag deployment would not provide additional occupant protection.

However, side and curtain air bags may inflate depending on the severity, vehicle speed and angles of impact.

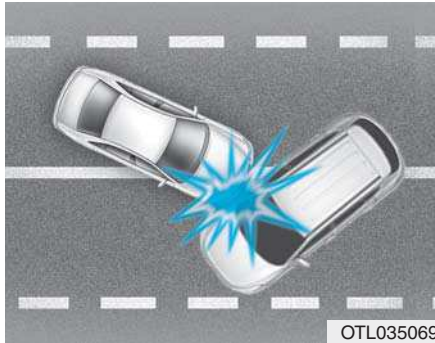

OTL035069

In an angled collision, the force of impact may direct the occupants in a direction where the air bags would not be able to provide any additional benefit, and thus the sensors may not deploy any air bags.

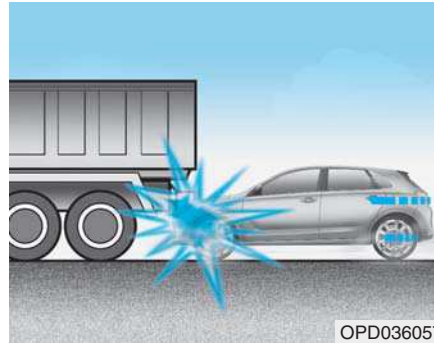

OPD036057

Just before impact, drivers often brake heavily. Such heavy braking lowers the front portion of the vehicle causing it to “ride” under a vehicle with a higher ground clearance. Air bags may not inflate in this “underride” situation because deceleration forces that are detected by sensors may be significantly reduced by such “underride” collisions.

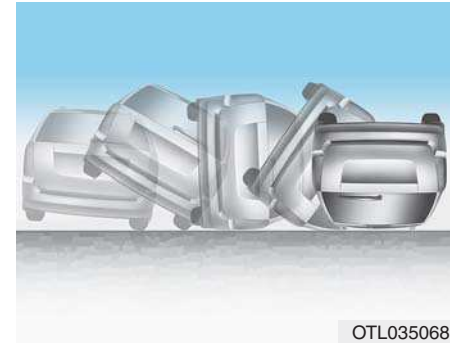

OTL035068

Front air bags may not inflate in rollover accidents because front air bag deployment would not provide additional occupant protection.

### **i** Information

- **Vehicles equipped with rollover sensor**  
The side and curtain air bags may inflate in a rollover situation, when it is detected by the rollover sensor.
- **Vehicles not equipped with rollover sensor**  
The side and/or curtain air bags may inflate when the vehicle is rolled over by a side impact collision, if the vehicle is equipped with side and/or curtain air bags.



Air bags may not inflate if the vehicle collides with objects such as utility poles or trees, where the point of impact is concentrated and the collision energy is absorbed by the vehicle structure.

### SRS care

The SRS is virtually maintenance-free and there are no parts you can safely service by yourself. If the SRS air bag warning light does not illuminate when the ignition switch is in the ON position, or continuously remains on, we recommend that the system be immediately inspected by an authorized HYUNDAI dealer.

We recommend any work on the SRS system, such as removing, installing, repairing, or any work on the steering wheel, the front passenger's panel, front seats and roof rails be performed by an authorized HYUNDAI dealer. Improper handling of the SRS system may result in serious personal injury.

#### WARNING

To reduce the risk of serious injury or death take the following precautions:

- Do not attempt to modify or disconnect the SRS components or wiring, including the addition of any kind of badges to the pad covers or modifications to the body structure.

(Continued)

(Continued)

- Do not place objects over or near the air bag modules on the steering wheel, instrument panel, and the front passenger's panel above the glove box.
- Clean the air bag pad covers with a soft cloth moistened with plain water. Solvents or cleaners could adversely affect the air bag covers and proper deployment of the system.
- We recommend that inflated air bags be replaced by an authorized HYUNDAI dealer.
- If components of the air bag system must be discarded, or if the vehicle must be scrapped, certain safety precautions must be observed. Consult an authorized HYUNDAI dealer for the necessary information. Failure to follow these precautions could increase the risk of personal injury.



## Additional safety precautions

**Passengers should not move out of or change seats while the vehicle is moving.** A passenger who is not wearing a seat belt during a crash or emergency stop can be thrown against the inside of the vehicle, against other occupants, or be ejected from the vehicle.

**Do not use any accessories on seat belts.** Devices claiming to improve occupant comfort or reposition the seat belt can reduce the protection provided by the seat belt and increase the chance of serious injury in a crash.

### **Do not modify the front seats.**

Modification of the front seats could interfere with the operation of the supplemental restraint system sensing components or side air bags.

**Do not place items under the front seats.** Placing items under the front seats could interfere with the operation of the supplemental restraint system sensing components and wiring harnesses.

**Do not cause impact to the doors.** Impact to the doors when the ignition switch is in the ON position may cause the air bags to inflate.

## ***Adding equipment to or modifying your air bag equipped vehicle***

If you modify your vehicle by changing your vehicle's frame, bumper system, front end or side sheet metal or ride height, this may affect the operation of your vehicle's air bag system.

## Air bag warning labels



Air bag warning labels are attached to alert the passengers of potential risks of the air bag system.

Be sure to read all of the information about the air bags that are installed on your vehicle in this Owner's Manual.

## Convenient features of your vehicle

<b>Accessing your vehicle</b> .....	3-3
Remote key .....	3-3
Smart key .....	3-6
Immobilizer system .....	3-10
<b>Door locks</b> .....	3-11
Operating door locks from outside the vehicle .....	3-11
Operating door locks from inside the vehicle .....	3-12
Auto door lock/unlock features .....	3-14
Child-protector rear door locks .....	3-15
<b>Theft-alarm system</b> .....	3-16
<b>Driver position memory system</b> .....	3-17
Storing memory positions .....	3-17
Recalling memory positions .....	3-17
Easy access function .....	3-18
<b>Steering wheel</b> .....	3-19
Electric power steering (EPS) .....	3-19
Tilt steering / Telescopic steering .....	3-20
Heated steering wheel .....	3-21
Horn .....	3-21
<b>Mirrors</b> .....	3-22
Inside rearview mirror .....	3-22
Outside rearview mirror .....	3-23
Reverse parking aid function .....	3-26
<b>Windows</b> .....	3-27
Power windows .....	3-27
Remote window closing function .....	3-31
<b>Panorama sunroof</b> .....	3-32
Sunshade .....	3-33
Sliding the sunroof .....	3-33
Tilting the sunroof .....	3-34
Closing the sunroof .....	3-34
Resetting the sunroof .....	3-35
Sunroof open warning .....	3-36
<b>Exterior features</b> .....	3-37
Hood .....	3-37
Tailgate .....	3-38
Fuel filler door .....	3-40
<b>Instrument cluster</b> .....	3-43
Instrument cluster control .....	3-44
Gauges and meters .....	3-44
Manual transmission shift indicator .....	3-48
Shift lights .....	3-48
Warning and indicator lights .....	3-49
LCD display messages .....	3-61
<b>LCD Display</b> .....	3-67
LCD display control .....	3-67
LCD display modes .....	3-68
<b>Trip computer</b> .....	3-76
Trip modes .....	3-76

<b>Lighting</b> .....	3-79	<b>Climate control additional features</b> .....	3-118
Exterior lights .....	3-79	Cluster ionizer.....	3-118
Static bending light.....	3-86	Automatic ventilation.....	3-118
Welcome system.....	3-87	Sunroof inside air recirculation.....	3-118
Interior lights.....	3-88	<b>Storage compartment</b> .....	3-119
<b>Wipers and washers</b> .....	3-91	Center console storage .....	3-119
Windshield wipers .....	3-91	Glove box .....	3-119
Windshield washers .....	3-93	Sunglass holder .....	3-120
Rear window wiper and washer switch.....	3-94	<b>Interior features</b> .....	3-121
<b>Driver assist system</b> .....	3-95	Ashtray .....	3-121
Rear view camera .....	3-95	Cup holder.....	3-121
Rear parking assist system .....	3-96	Sunvisor.....	3-122
Parking assist system .....	3-100	Power outlet.....	3-123
<b>Automatic climate control system</b> .....	3-103	Cigarette lighter .....	3-124
Automatic heating and air conditioning.....	3-104	Wireless cellular phone charging system.....	3-125
Manual heating and air conditioning.....	3-105	Clock.....	3-126
System operation.....	3-110	Clothes hanger .....	3-127
System maintenance .....	3-113	Floor mat anchor(s).....	3-127
<b>Windshield defrosting and defogging</b> .....	3-115	Luggage net (holder) .....	3-128
Automatic climate control system .....	3-115	Cargo area cover .....	3-129
Defroster.....	3-116		
Auto defogging system .....	3-117		

## ACCESSING YOUR VEHICLE

### Remote key (if equipped)



Your HYUNDAI uses a remote key, which you can use to lock or unlock a door (and tailgate) and even start the engine.

1. Door Lock
2. Door Unlock
3. Tailgate Unlock

### Locking

To lock :

1. Close all doors, engine hood and tailgate.
2. Press the Door Lock button (1) on the remote key.
3. The doors will lock. The hazard warning lights will blink. Also, the outside rearview mirror will fold, if the outside rearview mirror folding switch is in the AUTO position (if equipped).
4. When the doors are locked, the indicator light on the central door lock/unlock switch will be illuminated.

### **!** WARNING

**Do not leave the keys in your vehicle with unsupervised children. Unattended children could place the key in the ignition switch and may operate power windows or other controls, or even make the vehicle move, which could result in serious injury or death.**

### Unlocking

To unlock:

1. Press the Door Unlock button (2) on the remote key.
2. The doors will unlock. The hazard warning lights will blink two times. Also, the outside rearview mirror will unfold, if the outside rearview mirror folding switch is in the AUTO position (if equipped).

### **i** Information

**After unlocking the doors, the doors will lock automatically after 30 seconds unless a door is opened.**

### Tailgate unlocking

To unlock:

1. Press the Tailgate Unlock button (3) on the remote key for more than one second.
2. The hazard warning lights will blink two times and the tailgate will be unlocked.

### **i** Information

The word "HOLD" is written on the button to inform you that you must press and hold the button for more than one second.

### Start-up

For detailed information refer to “Key Ignition Switch” in chapter 5.

#### NOTICE

To prevent damaging the remote key:

- Keep the remote key away from water or any liquid and fire. If the inside of the smart key gets damp (due to drinks or moisture), or is heated, internal circuit may malfunction and may void the vehicle warranty.
- Avoid dropping or throwing the remote key.
- Protect the remote key from extreme temperatures.

### Mechanical key



If the remote key does not operate normally, you can lock or unlock the door by using the mechanical key.

To unfold the key, press the release button then the key will unfold automatically.

To fold the key, fold the key manually while pressing the release button.

#### NOTICE

**Do not fold the key without pressing the release button. This may damage the key.**

### Remote key precautions

The remote key will not work if any of the following occur:

- The key is in the ignition switch.
- You exceed the operating distance limit (about 30 m [90 feet]).
- The remote key battery is weak.
- Other vehicles or objects may be blocking the signal.
- The weather is extremely cold.
- The remote key is close to a radio transmitter such as a radio station or an airport which can interfere with normal operation of the remote key.

If the remote key does not work correctly, open and close the door with the mechanical key. If you have a problem with the remote key, it is recommended that you contact an authorized HYUNDAI dealer.

If the remote key is in close proximity to your mobile phone, the signal could be blocked by your mobile phone's normal operational signals.

This is specifically relevant when the phone is active such as making and receiving calls, text messaging, and/or sending/receiving emails.

Avoid placing the remote key and your mobile phone in the same location and always try to maintain an adequate distance between the two devices.

### **i** Information

Changes or modifications not expressly approved by the party responsible for compliance could void the user's authority to operate the equipment. If the keyless entry system is inoperative due to changes or modifications not expressly approved by the party responsible for compliance, it will not be covered by your manufacturer's vehicle warranty.

### **NOTICE**

**Keep the remote key away from electromagnetic materials that block electromagnetic waves to the key surface.**

### **Battery replacement**

If the remote key is not working properly, try replacing the battery with a new one.



Battery Type: CR2032

To replace the battery:

1. Insert a slim tool into the slot and gently pry open the cover.
2. Using a screw driver, remove the battery cover.
3. Remove the old battery and insert a new battery. Make sure the battery position is correct.
4. Reinstall the battery cover and key cover in the reverse order of removal.

If you suspect your remote key might have sustained some damage, or you feel your remote key is not working correctly, it is recommended that you contact an authorized HYUNDAI dealer.

### **i** Information



**An inappropriately disposed battery can be harmful to the environment and human health. Dispose of the battery according to your local law(s) or regulations.**

### Smart key (if equipped)



Your HYUNDAI uses a Smart Key, which you can use to lock or unlock a door (and tailgate) and even start the engine.

1. Door Lock
2. Door Unlock
3. Tailgate Unlock

### Locking



To lock :

1. Close all doors, engine hood and tailgate.
2. Either press the door handle button or press the Door Lock button (1) on the smart key.
3. The hazard warning lights will blink. Also, the outside rearview mirror will fold, if the outside rearview mirror folding switch is in the AUTO position (if equipped).
4. When the doors are locked, the indicator light on the central door lock/unlock switch will be illuminated.

### Information

The door handle button will only operate when the smart key is within 0.7~1 m (28~40 in.) from the outside door handle.

Even though you press the outside door handle button, the doors will not lock and the chime will sound for three seconds if any of the following occur:

- The Smart Key is in the vehicle.
- The Engine Start/Stop button is in ACC or ON position.
- Any door except the tailgate is open.

### WARNING

**Do not leave the Smart Key in your vehicle with unsupervised children. Unattended children could press the Engine Start/Stop button and may operate power windows or other controls, or even make the vehicle move, which could result in serious injury or death.**

## Unlocking



To unlock:

1. Carry the Smart Key.
2. Either press the door handle button or press the Door Unlock button (2) on the smart key.
3. The doors will unlock. The hazard warning lights will blink two times. Also, the outside rearview mirror will unfold, if the outside rearview mirror folding switch is in the AUTO position. (if equipped)

### **i** Information

- The door handle button will only operate when the smart key is within 0.7~1 m (28~40 in.) from the outside door handle. Other people can also open the doors without the smart key in possession.
- After unlocking the doors, the doors will lock automatically after 30 seconds unless a door is opened.

### **Tailgate unlocking**

To unlock:

1. Carry the smart key.
2. Either press the tailgate handle button or press the Tailgate Unlock button (3) on the smart key for more than one second.
3. The hazard warning lights will blink two times.

### **i** Information

- The Tailgate Unlock button (3) will only unlock the tailgate. It will not release the latch and open the tailgate automatically. If the Tailgate Unlock button is used, someone must still press the tailgate handle button to open the tailgate.
- After unlocking the tailgate, the tailgate will lock automatically after 30 seconds unless the tailgate is opened.



### Start-up

You can start the engine without inserting the key. **For detailed information refer to the Engine Start/Stop button in chapter 5.**

#### NOTICE

To prevent damaging the smart key:

- Keep the smart key away from water or any liquid and fire. If the inside of the smart key gets damp (due to drinks or moisture), or is heated, internal circuit may malfunction and may void the vehicle warranty.
- Avoid dropping or throwing the smart key.
- Protect the smart key from extreme temperatures.

#### NOTICE

Always have the smart key with you when leaving the vehicle. If the smart key is left near the vehicle, the vehicle battery may be discharged.

### Mechanical key

If the Smart Key does not operate normally, you can lock or unlock the door by using the mechanical key.



Move the release lever in the direction of the arrow (1) and then remove the mechanical key (2). Insert the mechanical key into the key hole on the door.

To reinstall the mechanical key, put the key into the hole and push it until a click sound is heard.

### Loss of a smart key

A maximum of two smart keys can be registered to a single vehicle. If you happen to lose your smart key, it is recommended that you should immediately take the vehicle and remaining key to your authorized HYUNDAI dealer or tow the vehicle, if necessary.

### Smart key precautions

The smart key may not work if any of the following occur:

- The smart key is close to a radio transmitter such as a radio station or an airport which can interfere with normal operation of the transmitter.
- The smart key is near a mobile two way radio system or a cellular phone.
- Another vehicle's smart key is being operated close to your vehicle.

If the smart key does not work correctly, open and close the door with the mechanical key. If you have a problem with the smart key, it is recommended that you contact an authorized HYUNDAI dealer.

If the smart key is in close proximity to your mobile phone, the signal could be blocked by your mobile phone's normal operational signals. This is specifically relevant when the phone is active such as making and receiving calls, text messaging, and/or sending/receiving emails.

Avoid placing the smart key and your mobile phone in the same location and always try to maintain an adequate distance between the two devices.

### **i** Information

**Changes or modifications not expressly approved by the party responsible for compliance could void the user's authority to operate the equipment. If the keyless entry system is inoperative due to changes or modifications not expressly approved by the party responsible for compliance, it will not be covered by your manufacturer's vehicle warranty.**

### **NOTICE**

**Keep the smart key away from electromagnetic materials that blocks electromagnetic waves to the key surface.**

### **NOTICE**

**Always have the smart key with you when leaving the vehicle. If the smart key is left near the vehicle, the vehicle battery may be discharged.**

### Battery replacement



OPDE046046

If the Smart Key is not working properly, try replacing the battery with a new one.

Battery Type: CR2032

To replace the battery:

1. Remove the mechanical key.
2. Use a slim tool to pry open the rear cover of the smart key.
3. Remove the old battery and insert the new battery. Make sure the battery position is correct.
4. Reinstall the rear cover of the smart key.

If you suspect your smart key might have sustained some damage, or you feel your smart key is not working correctly, it is recommended that you contact an authorized HYUNDAI dealer.

### **i** Information



**An inappropriately disposed battery can be harmful to the environment and human health. Dispose of the battery according to your local law(s) or regulations.**

### Immobilizer system (if equipped)

The immobilizer system protects your vehicle from theft. If an improperly coded key (or other device) is used, the engine's fuel system is disabled.

When the ignition switch is placed in the ON position, the immobilizer system indicator should come on briefly, then go off. If the indicator starts to blink, the system does not recognize the coding of the key.

Place the ignition switch to the LOCK/OFF position, then place the ignition switch to the ON position again.

The system may not recognize your key's coding if another immobilizer key or other metal object (i.e., key chain) is near the key. The engine may not start because the metal may interrupt the transponder signal from transmitting normally.

If the system repeatedly does not recognize the coding of the key, it is recommended that you contact your HYUNDAI dealer.

Do not attempt to alter this system or add other devices to it. Electrical problems could result that may make your vehicle inoperable.

### **⚠** WARNING

**In order to prevent theft of your vehicle, do not leave spare keys anywhere in your vehicle. Your immobilizer password is a customer unique password and should be kept confidential.**

### **NOTICE**

**The transponder in your key is an important part of the immobilizer system. It is designed to give years of trouble-free service, however you should avoid exposure to moisture, static electricity and rough handling. Immobilizer system malfunction could occur.**

## DOOR LOCKS

### Operating door locks from outside the vehicle

#### Mechanical key

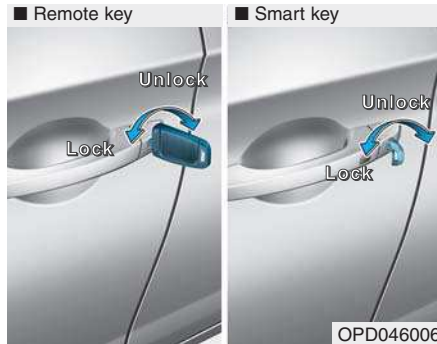

Turn the key toward the rear of the vehicle to unlock and toward the front of the vehicle to lock.

If you lock/unlock the driver's door with a key, a driver's door will lock/unlock automatically.

Once the doors are unlocked, they may be opened by pulling the door handle.

When closing the door, push the door by hand. Make sure that doors are closed securely.

#### Remote key



To lock the doors, press the Door Lock button (1) on the remote key.

To unlock the doors, press the Door Unlock button (2) on the remote key.

Once the doors are unlocked, they may be opened by pulling the door handle.

When closing the door, push the door by hand. Make sure that doors are closed securely.

#### Smart key



To lock the doors, press the button on the outside door handle while carrying the smart key with you or press the door lock button on the smart key.

## Convenient features of your vehicle

To unlock the doors, press the button on the outside door handle while carrying the smart key with you or press the door unlock button on the smart key.

Once the doors are unlocked, they may be opened by pulling the door handle.

When closing the door, push the door by hand. Make sure that doors are closed securely.

### **i** Information

- **In cold and wet climates, door lock and door mechanisms may not work properly due to freezing conditions.**
- **If the door is locked/unlocked multiple times in rapid succession with either the vehicle key or door lock switch, the system may stop operating temporarily in order to protect the circuit and prevent damage to system components.**

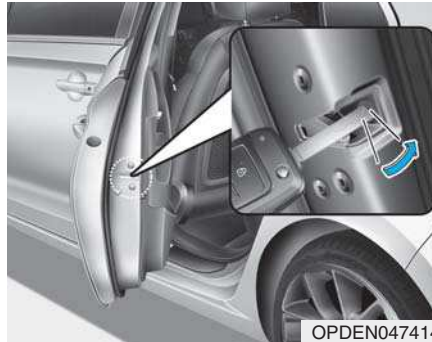

### **In case of an emergency**

If the electrical power door lock switch is not operating (ex. dead car battery) the only way to lock the door(s) is with the mechanical key from the outside key hole.

Doors without an outside key hole can be locked as follows:

1. Open the door.
2. Insert the key into the emergency door lock hole and turn the key horizontally to lock.
3. Close the door securely.

### **i** Information

If the electrical power to door lock switch is not operating (ex. dead car battery) and the tailgate is closed, you will not be able to open the tailgate until power is restored.

## Operating door locks from inside the vehicle

### **With the door handle**



### **Front door**

If the inner door handle is pulled when the door is locked, the door will unlock and open.

## Rear door

If the inner door handle is pulled once when the door is locked, the door will unlock.

If the inner door handle is pulled once more, the door will open.

### **i** Information

If a power door lock ever fails to function while you are in the vehicle try one or more of the following techniques to exit:

- Operate the door unlock feature repeatedly (both electronic and manual) while simultaneously pulling on the door handle.
- Operate the other door locks and handles, front and rear.
- Lower a front window and use the mechanical key to unlock the door from outside.

### *With the central door lock/unlock switch*



- With a door unlocked
  - If you press the central door lock switch, all vehicle doors will lock and the indicator light on the switch will illuminate.
  - If any door is opened when the switch is pressed, no doors will lock.
- With all doors locked
  - If you press the central door unlock switch, all vehicle doors will unlock.
  - If any door is unlocked, the indicator on the central door lock switch will go out.

### **i** Information

The indicator light on the switch blinks for approximately one minute when a door is unlocked or the tailgate is opened.

#### **⚠ WARNING**

- The doors should always be fully closed and locked while the vehicle is in motion. If the doors are unlocked, the risk of being thrown from the vehicle in a crash is increased.
- Do not pull the inner door handle of driver's(or passenger's) door while the vehicle is moving.

#### **⚠ WARNING**

**Do not leave children or animals unattended in your vehicle. An enclosed vehicle can become extremely hot, causing death or serious injury to unattended children or animals who cannot escape the vehicle.**

**(Continued)**

(Continued)

Children might operate features of the vehicle that could injure them, or they could encounter other harm, possibly from someone gaining entry to the vehicle.

### WARNING

Leaving your vehicle unlocked can allow theft or entry into the vehicle.

To secure your vehicle, while depressing the brake, move the shift lever to 1st gear when the vehicle is parked on a uphill and to R (Reverse) on a downhill, engage the parking brake, and place the ignition switch in the LOCK/OFF position, close all windows, lock all doors, and always take the key with you.

### WARNING

Opening a door when something is approaching may cause damage or injury. Be careful when opening doors and watch for vehicles, motorcycles, bicycles or pedestrians approaching the vehicle in the path of the door.

### WARNING

If you stay in the vehicle for a long time while the weather is very hot or cold, there are risks of injuries or danger to life. Do not lock the vehicle from the outside when someone is in the vehicle.

## Auto door lock/unlock features

### *Impact sensing door unlock system (if equipped)*

All doors will be automatically unlocked when an impact causes the air bags to deploy.

### *Speed sensing door lock system (if equipped)*

All doors will be automatically locked when vehicle speed exceeds 15 km/h (9 mph).

You can activate or deactivate the Auto Door Lock/Unlock features from the User Settings mode on the LCD display. For more details, refer to "LCD Display" in this chapter.

## Child-protector rear door locks



The child safety lock is provided to help prevent children seated in the rear from accidentally opening the rear doors. The rear door safety locks should be used whenever children are in the vehicle.

The child safety lock is located on the edge of each rear door. When the child safety lock is in the lock position, the rear door will not open if the inner door handle is pulled.

To lock the child safety lock, insert a key (or screwdriver) (1) into the hole and turn it to the lock position.

To allow a rear door to be opened from inside the vehicle, unlock the child safety lock.

### WARNING

**If children accidentally open the rear doors while the vehicle is in motion, they could fall out of the vehicle. The rear door safety locks should always be used whenever children are in the vehicle.**



### THEFT-ALARM SYSTEM

This system helps to protect your vehicle and valuables. The horn will sound and the hazard warning lights will blink continuously if any of the following occur:

- A door is opened without using the remote key or smart key.
- The tailgate is opened without using the remote key or smart key.
- The engine hood is opened.

The alarm continues for 30 seconds, then the system resets. To turn off the alarm, unlock the doors with the remote key or smart key.

The Theft Alarm System automatically sets 30 seconds after you lock the doors and the tailgate. For the system to activate, you must lock the doors and the tailgate from outside the vehicle with the remote key or smart key or by pressing the button on the outside of the door handles with the smart key in your possession.

The hazard warning lights will blink once to indicate the system is armed.

Once the security system is set, opening any door, the tailgate, or the hood without using the remote key or smart key will cause the alarm to activate.

The Theft Alarm System will not set if the hood, the tailgate, or any door is not fully closed. If the system will not set, check the hood, the tailgate, or the doors are fully closed.

Do not attempt to alter this system or add other devices to it.

#### **i** Information

- **Do not lock the doors until all passengers have left the vehicle. If the remaining passenger leaves the vehicle when the system is armed, the alarm will be activated.**
- **If the vehicle is not disarmed with the remote key or smart key, open the doors by using the mechanical key and place the ignition switch in the ON position (for remote key) or start the engine (for smart key) and wait for 30 seconds.**
- **When the system is disarmed but a door or tailgate is not opened within 30 seconds, the system will be rearmed.**



#### **i** Information

Vehicles equipped with a theft alarm system will have a label attached to the vehicle with the following words:

1. WARNING
2. SECURITY SYSTEM

## DRIVER POSITION MEMORY SYSTEM (IF EQUIPPED)



The Driver Position Memory System is provided to store and recall the following memory settings with a simple button operation.

- Driver's seat position
- Outside rearview mirror position
- Instrument panel illumination intensity

### WARNING

**Never attempt to operate the driver position memory system while the vehicle is moving.**

**This could result in loss of control, and an accident causing death, serious injury, or property damage.**

### Information

- If the battery is disconnected, the memory settings will be erased.
- If the Driver Position Memory System does not operate normally, we recommend that you have the system checked by an authorized HYUNDAI dealer.

### Storing memory positions

1. Place the ignition switch or the Engine Start/Stop button in the ON position.
2. Adjust the driver's seat position, outside rearview mirror position and instrument panel illumination intensity to the desired position.
3. Press the SET button. The system will beep once and notify you "Press button to save settings" on the LCD display.
4. Press one of the memory buttons (1 or 2) within 4 seconds. The system will beep twice when the memory has been successfully stored.
5. "Driver 1 (or 2) settings saved" will appear on the LCD display.

### Recalling memory positions

1. Place the ignition switch or the Engine Start/Stop button in the ON position.
2. Press the desired memory button (1 or 2). The system will beep once, then the driver's seat position, outside rearview mirror and instrument panel illumination will automatically adjust to the stored position.
3. "Driver 1(or 2) settings is applied" will appear on the LCD display.

### Information

- While recalling the "1" memory position, pressing the SET or 1 button temporarily stops the adjustment of the recalled memory position. Pressing the 2 button recalls the "2" memory position.
- While recalling the "2" memory position, pressing the SET or 2 button temporarily stops the adjustment of the recalled memory position. Pressing the 1 button recalls the "1" memory position.
- While recalling the stored positions, pressing one of the control buttons for the driver's seat, outside rearview mirror, or instrument panel illumination will cause the movement of that component to stop and move in the direction that the control button is pressed.

### Easy access function (if equipped)

The system will move the driver's seat automatically as follows:

- Without smart key system
  - It will move the driver's seat rearward when the ignition key is removed and the driver's door is opened.
  - It will move the driver's seat forward when the ignition key is inserted.
- With smart key system
  - It will move the driver's seat rearward when the Engine Start/Stop button is in the OFF position and the driver's door is opened.
  - It will move the driver's seat forward when the vehicle is turned ON or the driver's door is closed with the smart key with you.

You can activate or deactivate the Easy Access Function from the User Settings mode on the LCD display.

**For more details, refer to "LCD Display" in this chapter.**



### CAUTION

**Driver should be cautious when using this function to assure no injury to passenger or child on the back seat. In case of emergency the driver has to stop movement of front seat (when easy access feature is activated) by pressing SET button or any of the driver seat control switches.**

## STEERING WHEEL

### Electric power steering (EPS)

The system assists you with steering the vehicle. If the engine is off or if the power steering system becomes inoperative, the vehicle may still be steered, but it will require increased steering effort.

Also, the steering effort becomes heavier as the vehicle's speed increases and becomes lighter as the vehicle's speed decreases for better control of the steering wheel.

Should you notice any change in the effort required to steer during normal vehicle operation, we recommend that the system be checked by an authorized HYUNDAI dealer.

#### NOTICE

- **If the Electric Power Steering System does not operate normally, the warning light (⊕!) will illuminate or blink on the instrument cluster. The steering wheel may become difficult to control or operate. Take your vehicle to an authorized HYUNDAI dealer and have the system checked as soon as possible.**
- **When abnormality is detected in the electric power steering system, to prevent a deadly accident, the steering assist function will stop. At this time, the warning light turns on or blinks on the cluster. The steering wheel may become difficult to control or operate. Have your vehicle checked immediately, after moving the vehicle to a safe zone.**

#### Information

The following symptoms may occur during normal vehicle operation:

- The steering effort may be high immediately after placing the ignition switch button in the ON position.
- This happens as the system performs the EPS system diagnostics. When the diagnostics are completed, the steering wheel will return to its normal condition.
- A click noise may be heard from the EPS relay after the ignition switch is placed in the ON or LOCK/OFF position.
- Motor noise may be heard when the vehicle is at a stop or at a low driving speed.
- When you operate the steering wheel in low temperatures, abnormal noise may occur. If the temperature rises, the noise will disappear. This is a normal condition.

(Continued)

(Continued)

- When the vehicle is stationary, if you turn the steering wheel all the way to the left or right continuously, the steering effort increases. This is not a system malfunction. As time passes, the steering wheel effort will return to its normal condition.

### Tilt steering / Telescopic steering

Adjust the steering wheel so it points toward your chest, not toward your face. Make sure you can see the instrument cluster warning lights and gauges. After adjusting, push the steering wheel both up and down to be certain it is locked in position. Always adjust the position of the steering wheel before driving.

#### WARNING

**Never adjust the steering wheel while driving. You may lose steering control and cause severe personal injury, death or accidents.**

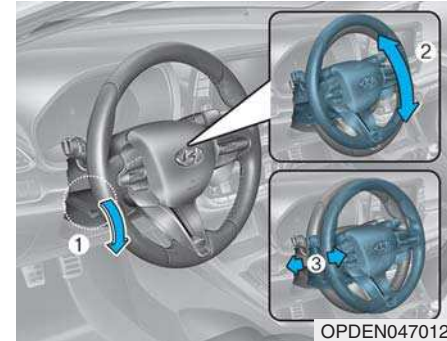

To change the steering wheel angle and height:

1. Pull down the lock-release lever (1).
2. Adjust the steering wheel to the desired angle (2) and distance forward/back (3).
3. Pull up the lock-release lever to lock the steering wheel in place.

#### Information

After adjustment, sometimes the lock-release lever may not lock the steering wheel.

**It is not a malfunction. This occurs when two gears are not engaged correctly. In this case, adjust the steering wheel again and then lock the steering wheel.**

## Heated steering wheel (if equipped)



When the ignition switch is in the ON position or when the engine is running, press the heated steering wheel button to warm the steering wheel. The indicator on the button will illuminate.

To turn the heated steering wheel off, press the button again. The indicator on the button will turn off.

## **i** Information

The heated steering wheel will turn off automatically approximately 30 minutes after the heated steering wheel is turned on.

When the engine is turned off during the engine and the heated steering wheel is on, the timer function of heated steering wheel will be reset.

To reuse heated steering wheel, press button again.

### **NOTICE**

**Do not install any cover or accessory on the steering wheel. This cover or accessory could cause damage to the heated steering wheel system.**

## Horn



To sound the horn, press the area indicated by the horn symbol on your steering wheel. The horn will operate only when this area is pressed.

### **NOTICE**

**Do not strike the horn severely to operate it, or hit it with your fist. Do not press on the horn with a sharp-pointed object.**

## MIRRORS

### Inside rearview mirror

Before you start driving, adjust the rearview mirror to the center on the view through the rear window.

#### WARNING

**Make sure your line of sight is not obstructed. Do not place objects in the rear seat, cargo area, or behind the rear headrests which could interfere with your vision through the rear window.**

#### WARNING

**To prevent serious injury during an accident or deployment of the air bag, do not modify the rearview mirror and do not install a wide mirror.**

#### WARNING

**NEVER adjust the mirror while driving. This may cause loss of vehicle control resulting in an accident.**

#### NOTICE

**When cleaning the mirror, use a paper towel or similar material dampened with glass cleaner. Do not spray glass cleaner directly on the mirror as that may cause the liquid cleaner to enter the mirror housing.**

### *Electric Chromic Mirror (ECM)*

The electric rearview mirror automatically controls the glare from the headlamp of the vehicle behind you in nighttime or low light driving conditions.

When the engine is running, the glare is automatically controlled by the sensor mounted in the rearview mirror. The sensor detects the light level around the vehicle, and automatically adjusts to control the headlamp glare from vehicles behind you.

Whenever the shift lever is placed in R (Reverse), the mirror will automatically go to the brightest setting in order to improve the driver's view behind the vehicle.



### To operate the electric rearview mirror:

- Press the ON/OFF button (1) to turn the automatic dimming function off. The mirror indicator light will turn off.  
Press the ON/OFF button (1) to turn the automatic dimming function on. The mirror indicator light will illuminate.
- The mirror defaults to the ON position whenever the ignition switch is in the ON position.

## Outside rearview mirror



Be sure to adjust mirror angles before driving.

Your vehicle is equipped with both left-hand and right-hand outside rearview mirrors.

The mirror can be adjusted remotely with the remote switch.

The mirror heads can be folded to prevent damage during an automatic car wash or when passing through a narrow street.

### WARNING

- The right outside rearview mirror is convex. In some countries, the left outside rearview mirror is also convex. Objects seen in the mirror are closer than they appear.
- Use your interior rearview mirror or turn your head and look to determine the actual distance of following vehicles when changing lanes.

### WARNING

**Do not adjust or fold the outside rearview mirrors while driving. This may cause loss of vehicle control resulting in an accident.**



### NOTICE

- Do not scrape ice off the mirror face; this may damage the surface of the glass.
- If the mirror is jammed with ice, do not adjust the mirror by force. Use an approved spray de-icer (not radiator antifreeze) spray, or a sponge or soft cloth with very warm water, or move the vehicle to a warm place and allow the ice to melt.

### Adjusting the rearview mirrors



1. Press either the L (left side) or R (right side) button (1) to select the rearview mirror you would like to adjust.
2. Use the mirror adjustment control (2) to position the selected mirror up, down, left or right.
3. After adjustment, put the button into neutral (center) position to prevent inadvertent adjustment.

### NOTICE

- The mirrors stop moving when they reach the maximum adjusting angles, but the motor continues to operate while the switch is pressed. Do not press the switch longer than necessary, the motor may be damaged.
- Do not attempt to adjust the outside rearview mirror by hand otherwise the motor may be damaged.

## Folding the outside rearview mirror



### Manual type

To fold the outside rearview mirror, grasp the housing of the mirror and then fold it toward the rear of the vehicle.



### Electric type

**Left** : The mirror will unfold.

**Right** : The mirror will fold.

**Center (AUTO)** : The mirror will fold or unfold automatically as follows:

- Without smart key system
  - The mirror will fold or unfold when the door is locked or unlocked by the remote key.
- With smart key system
  - The mirror will fold or unfold when the door is locked or unlocked by the smart key.
  - The mirror will fold or unfold when the door is locked or unlocked by the button on the outside door handle.

### NOTICE

The electric type outside rearview mirror operates even though the ignition switch is in the OFF position. However, to prevent unnecessary battery discharge, do not adjust the mirrors longer than necessary while the engine is not running.

### NOTICE

Do not fold the electric type outside rearview mirror by hand. It could cause motor failure.

### Reverse parking aid function (if equipped)



When you move the shift lever to the R (Reverse) position, the outside rearview mirror(s) will rotate downwards to aid with driving in reverse.

The position of the outside rearview mirror switch (1) determines whether or not the mirrors will move:

**Left/Right :** When either the L (Left) or R (Right) switch is selected, both outside rearview mirrors will move.

**Neutral :** When neither switch is selected, the outside rearview mirrors will not move.

The outside rearview mirrors will automatically revert to their original positions if any of the following occur:

- The ignition switch is placed to either the LOCK/OFF position or the ACC position.
- The shift lever is moved to any position except R (Reverse).
- The outside rearview mirror switch is not selected.

## WINDOWS

### Power windows

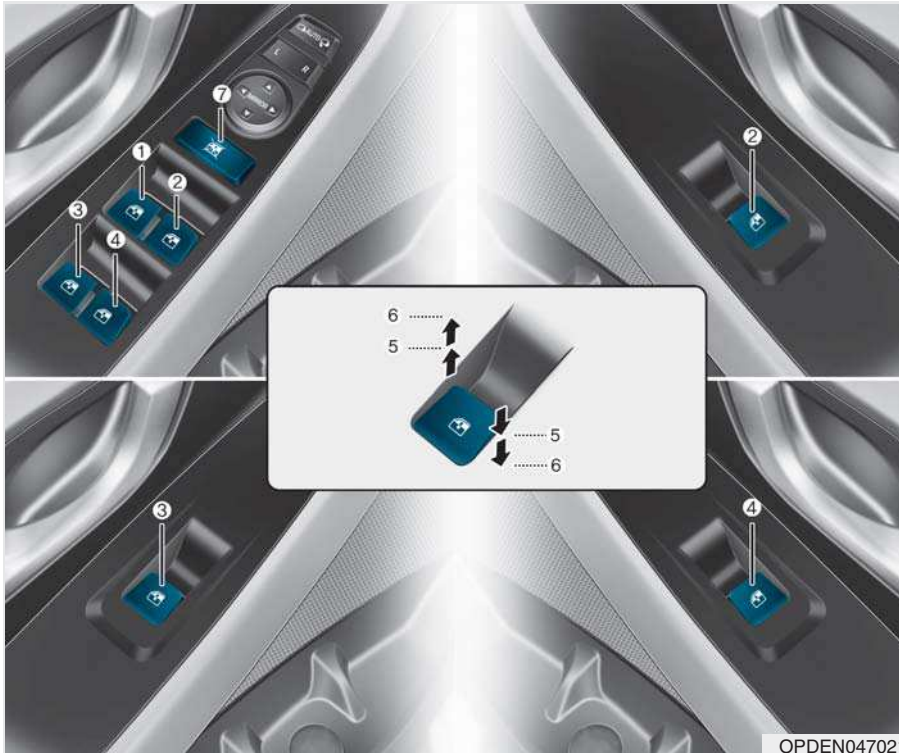

OPDEN047021

- (1) Driver's door power window switch
- (2) Front passenger's door power window switch
- (3) Rear door (left) power window switch
- (4) Rear door (right) power window switch
- (5) Window opening and closing
- (6) Automatic power window
- (7) Power window lock switch

The ignition switch must be in the ON position to be able to raise or lower the windows. Each door has a Power Window switch to control that door's window. The driver has a Power Window Lock switch which can block the operation of passenger windows. The power windows will operate for approximately 30 seconds after the ignition switch is placed in the ACC or OFF position. However, if the front doors are opened, the Power Windows cannot be operated even within the 30 second period.

### WARNING

**To avoid serious injury or death, do not extend your head, arms or body outside the windows while driving.**

### Information

- **In cold and wet climates, power windows may not work properly due to freezing conditions.**
- **While driving with the rear windows down or with the sunroof (if equipped) opened (or partially opened), your vehicle may demonstrate a wind buffeting or pulsation noise. This noise is normal and can be reduced or eliminated by taking the following actions. If the noise occurs with one or both of the rear windows down, partially lower both front windows approximately 2.5 cm. If you experience the noise with the sunroof open, slightly close the sunroof.**

### Window opening and closing



To open:

Press the window switch down to the first detent position (5). Release the switch when you want the window to stop.

To close:

Pull the window switch up to the first detent position (5). Release the window switch when you want the window to stop.

### **Auto up/down window**

Pressing or pulling up the power window switch momentarily to the second detent position (6) completely lowers or lifts the window even when the switch is released. To stop the window at the desired position while the window is in operation, pull up or press down and release the switch.

### **To reset the power windows**

If the power windows do not operate normally, the automatic power window system must be reset as follows:

1. Place the ignition switch to the ON position.
2. Close the window and continue pulling up on the power window switch for at least one second.

If the power windows do not operate properly after resetting, it is recommended that the system be checked by an authorized HYUNDAI dealer.

#### **⚠ WARNING**

**The automatic reverse feature doesn't activate while resetting the power window system. Make sure body parts or other objects are safely out of the way before closing the windows to avoid injuries or vehicle damage.**

### **Automatic reverse**

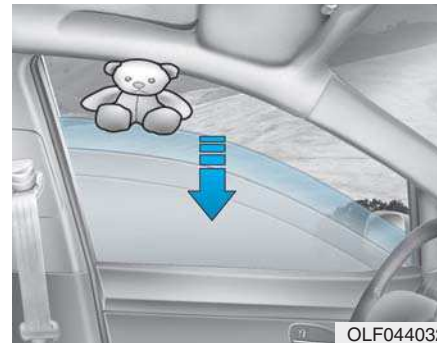

If a window senses any obstacle while it is closing automatically, it will stop and lower approximately 30 cm (12 inches) to allow the object to be cleared.

If the window detects the resistance while the power window switch is pulled up continuously, the window will stop upward movement then lower approximately 2.5 cm (1 inch).

If the power window switch is pulled up continuously again within 5 seconds after the window is lowered by the automatic window reverse feature, the automatic window reverse will not operate.

### **i** Information

The automatic reverse feature is only active when the “Auto Up” feature is used by fully pulling up the switch to the second detent.

#### **⚠** WARNING

Make sure body parts or other objects are safely out of the way before closing the windows to avoid injuries or vehicle damage.

Objects less than 4 mm (0.16 inch) in diameter caught between the window glass and the upper window channel may not be detected by the automatic reverse window and the window will not stop and reverse direction.

#### **NOTICE**

Do not install any accessories on the windows. The automatic reverse feature may not operate.

### Power window lock switch



The driver can disable the power window switches on the rear passengers' doors by pressing the power window lock switch.

When the power window lock switch is pressed:

- The driver's master control can operate all the power windows.
- The front passenger's control can operate the front passenger's power window.
- The rear passenger's control cannot operate the rear passengers' power window.

#### **⚠** WARNING

Do not allow children to play with the power windows. Keep the driver's door power window lock switch in the LOCK position. Serious injury or death can result from unintentional window operation by a child.

#### **NOTICE**

- To prevent possible damage to the power window system, do not open or close two windows or more at the same time. This will also ensure the longevity of the fuse.
- Never try to operate the main switch on the driver's door and the individual door window switch in opposite directions at the same time. If this is done, the window will stop and cannot be opened or closed.

## WARNING

- **NEVER** leave the keys in your vehicle with unsupervised children, when the engine is running.
- **NEVER** leave any child unattended in the vehicle. Even very young children may inadvertently cause the vehicle to move, entangle themselves in the windows, or otherwise injure themselves or others.
- **Always double check** to make sure all arms, hands, head and other obstructions are safely out of the way before closing a window.
- **Do not allow children to play with the power windows. Keep the driver's door power window lock switch in the LOCK position (pressed). Serious injury can result from unintentional window operation by the child.**
- **Do not extend your head, arms or body outside the windows while driving.**

## Remote window closing function (if equipped)



OPD047044L

You can still control the window movement with the engine turned off by pressing the door lock button (1) for more than 3 seconds. The window moves (up), as long as you press the door lock button. The window movement stops, when you release the door lock button. The hazard warning lights blink 3 times, when the window is completely closed.

## Information

- The remote window closing function may abruptly stop, when you move away from your vehicle during the operation. Stay in close proximity of your vehicle, while monitoring the window movement.
- One of the windows may stop operating, when the window is interrupted by certain force. However, the other windows will keep operating. Thus, you should make sure that all windows are closed, and that the hazard warning lights blink 3 times.



## PAORAMA SUNROOF (IF EQUIPPED)

If your vehicle is equipped with a sunroof, you can slide or tilt your sunroof with the sunroof control lever located on the overhead console.



The ignition switch must be in the ON position before you can open or close the sunroof.

The sunroof can be operated for approximately 30 seconds after the ignition key is removed or turned to the ACC or LOCK(or OFF) position. However, if the front door is opened, the sunroof cannot be operated even within 30 seconds.

### **i** Information

- In cold and wet climates, the sunroof may not work properly due to freezing conditions.
- After the vehicle is washed or in a rainstorm, be sure to wipe off any water that is on the sunroof before operating it.

### **NOTICE**

- Do not continue to move the sunroof control lever after the sunroof is fully opened, closed, or tilted. Damage to the motor or system components could occur.
- Make sure the sunroof is closed fully when leaving your vehicle. If the sunroof is open, rain or snow may leak through the sunroof and wet the interior as well as allow theft.

### **⚠ WARNING**

- Never adjust the sunroof or sunshade while driving. This could result in loss of control and an accident that may cause death, serious injury, or property damage.
- Make sure heads, other body parts or objects are out of the way before using the sunroof.
- Do not leave the engine running and the key in your vehicle with unsupervised children. Unattended children could operate the sunroof, which could result in serious injury.
- The panorama sunroof is made of glass, subject to break in case of accident. Passengers without the appropriate protection(e.g. seat belt, CRS, etc.) on may project out through the broken glasses and get seriously injured or even result in death.
- Do not sit on the top of the vehicle. It may cause injuries or vehicle damage.

## Sunshade



- To open the sunshade, pull the sunroof control lever backward (1) to the first detent position.
- To close the sunshade when the sunroof glass is closed, push the sunroof control lever forward (2).

To stop the sunroof movement at any point, push the sunroof control lever either forward or backward momentarily.

### **i** Information

Activating the control lever to the first detent requires only a very light touch.

## Sliding the sunroof

### *When the sunshade is closed*



If you pull the sunroof control lever backward past the first detent, the sunshade will slide all the way open and then the sunroof glass will slide all the way open.

To stop the sunroof movement at any point, push the sunroof control lever either forward or backward momentarily.

### *When the sunshade is opened*

If you pull the sunroof control lever backward, the sunroof glass will slide all the way open. To stop the sunroof movement at any point, pull or push the sunroof control lever momentarily.

### **i** Information

Only the front glass of the panorama sunroof opens and closes.

### Tilting the sunroof



#### **When the sunshade is closed**

If you push the sunroof control lever upward, the sunshade will slide open then the sunroof glass will tilt open.

To stop the sunroof movement at any point, push the sunroof control lever either forward or backward momentarily.

#### **When the sunshade is opened**

If you push the sunroof control lever upward, the sunroof glass will tilt open.

To stop the sunroof movement at any point, push the sunroof control lever either forward or backward momentarily.

### Closing the sunroof



#### **To close sunroof glass**

Push the sunroof control lever forward to the first detent position.

#### **To close sunroof glass with sunshade**

Push the sunroof control lever forward to the second detent position. The sunroof glass will close then the sunshade will close automatically.

To stop the sunroof movement at any point, push the sunroof control lever either forward or backward momentarily.

### Automatic reverse (if equipped)

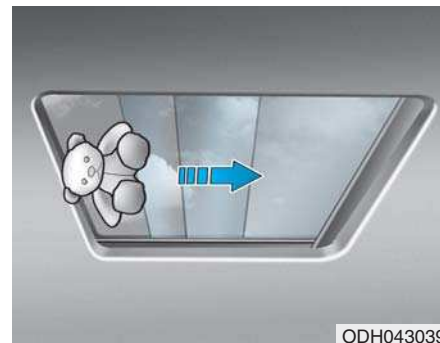

If the sunroof senses any obstacle while it is closing automatically, it will reverse direction then stop to allow the object to be cleared.

#### **⚠ WARNING**

**Small objects that can get caught between the sunroof glass and the front glass channel may not be detected by the automatic reverse system. In this case, the sunroof glass will not detect the object and will not reverse direction.**

## WARNING

- In order to prevent accidental operation of the sunroof, especially by a child, do not let a child operate the sunroof.
- Do not sit on the top of the vehicle. It may cause vehicle damage.

## NOTICE

- Periodically remove any dirt that may accumulate on the sunroof guide rail or between the sunroof and roof panel, which can make a noise.
- Do not try to open the sunroof when the temperature is below freezing or when the sunroof is covered with snow or ice, otherwise the motor could be damaged. In cold and wet climates, the sunroof may not work properly.

## Resetting the sunroof



The sunroof may need to be reset if the following conditions occur:

- The battery is discharged or disconnected or the sunroof fuse has been replaced or disconnected
- The sunroof control lever is not operating correctly

To reset the sunroof, perform the following steps:

1. Turn the engine on and close the sunroof glass and sunshade completely.
2. Release the control lever.

3. Push and hold the sunroof control lever forward (to close the sunshade) for about 10 seconds until the sunroof moves slightly, then release the control lever.
4. Push and hold the sunroof control lever forward until the sunroof operates as follows:

Sunshade Open → Glass Tilt Open  
→ Glass Slide Open → Glass Slide Close  
→ Sunshade Close

Then, release the control lever.

When this is complete, the sunroof system is reset.

For more details, contact an authorized HYUNDAI dealer.

## Information

**If you do not reset the sunroof, it may not work properly.**

### Sunroof open warning (if equipped)

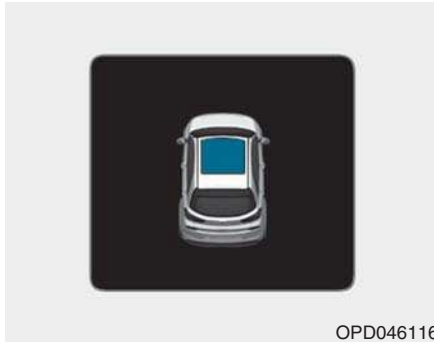

- If the driver turns off the engine when the sunroof is not fully closed, the warning chime will sound for approximately 3 seconds and the sunroof open warning will appear on the LCD display.
- If the driver turns off the engine and opens the door when the sunroof is not fully closed, the open sunroof warning will appear on the LCD display until the door is closed or the sunroof is fully closed.

Close the sunroof securely when leaving your vehicle.

## EXTERIOR FEATURES

### Hood

#### Opening the hood

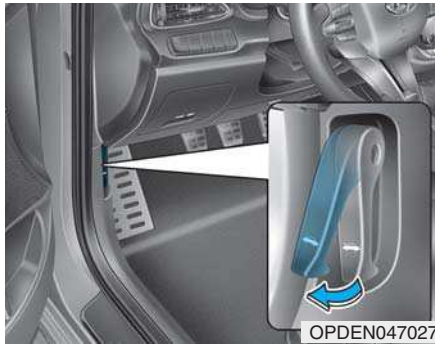

1. Park the vehicle and set the parking brake.
2. Pull the release lever to unlatch the hood. The hood should pop open slightly.

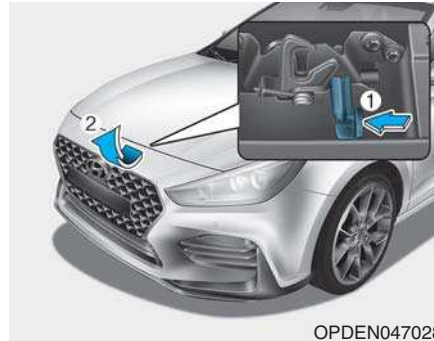

3. Go to the front of the vehicle, raise the hood slightly, push the secondary latch up (1) inside the hood center and lift the hood (2).
4. Pull out the support rod.



5. Hold the hood open with the support rod (1).

#### WARNING

- Grasp the support rod in the area wrapped in rubber. The rubber will help prevent you from being burned by hot metal when the engine is hot.
- The support rod must be inserted completely into the hole provided whenever you inspect the engine compartment. This will prevent the hood from falling and possibly injuring you.

### Closing the hood

1. Before closing the hood, check the following:
  - All filler caps in engine compartment must be correctly installed.
  - Gloves, rags or any other combustible material must be removed from the engine compartment.
2. Return the support rod to its clip to prevent it from rattling.
3. Lower the hood halfway (lifted approximately 30cm from the closed position) and push down to securely lock in place. Then double check to be sure the hood is secure. If the hood can be raised slightly, it is not securely locked. Open it again and close it with more force.

### WARNING

- **Before closing the hood, ensure all obstructions are removed from around the hood opening.**
- **Always double check to be sure that the hood is firmly latched before driving away. Check there is no hood open warning light or message displayed on the instrument cluster. If the hood is not latched while the vehicle is moving, the chime will sound to warn the driver the hood is not fully latched. Driving with the hood opened may cause a total loss of visibility, which might result in an accident.**
- **Do not move the vehicle with the hood in the raised position, as vision is obstructed, which might result in an accident, and the hood could fall or be damaged.**

### Tailgate

#### Opening the tailgate

Make sure the vehicle is in P (Park) and set the parking brake.

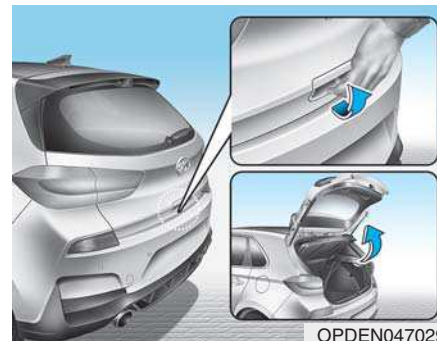

Then do one of the following:

1. Unlock all doors with the Door Unlock button on your remote key or smart key. Press the tailgate handle button and open the tailgate.
2. Press and hold the Tailgate Unlock button on the remote key or smart key. Press the tailgate handle button and open the tailgate.
3. With the Smart Key in your possession, press the tailgate handle button and open the tailgate.

## Closing the tailgate



Lower the tailgate lid and press down until it locks. To be sure the tailgate lid is securely fastened, always check by trying to pull it up again without pressing the tailgate handle button.

### WARNING

**Always keep the tailgate lid completely closed while the vehicle is in motion. If it is left open or ajar, poisonous exhaust gases containing carbon monoxide (CO) may enter the vehicle and serious illness or death may result.**

### Information

To prevent damage to the tailgate lift cylinders and the attached hardware, always close the tailgate before driving.

### NOTICE

In cold and wet climates, tailgate lock and tailgate mechanisms may not work properly due to freezing conditions.

### WARNING



**Do not hold the part (gas lifter) that supports the tailgate. Be aware that the deformation of the part may cause vehicle damage and a risk of safety accident.**



**⚠ WARNING**

- **NEVER** allow anyone to occupy the luggage compartment of the vehicle at any time. If the tailgate is partially or totally latched and the person is unable to get out, serious injury or death could occur due to lack of ventilation, exhaust fumes and rapid heat build-up, or because of exposure to cold weather conditions. The luggage compartment is also a highly dangerous location in the event of a crash because it is not a protected occupant space but is a part of the vehicle's crush zone.
- Your vehicle should be kept locked and keys should be kept out of the reach of children. Parents should teach their children about the dangers of playing in luggage compartments.

### Fuel filler door

#### Opening the fuel filler door



1. Turn the engine off.
2. Ensure the driver's door is unlocked.
3. Push the fuel filler door near the 3 o'clock position.

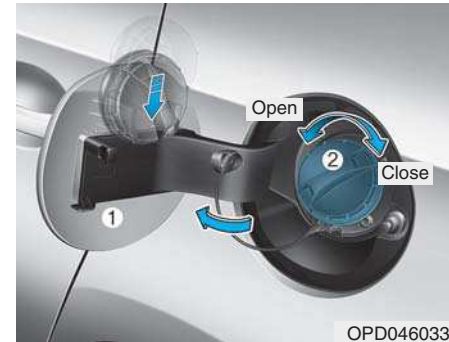

4. Pull the fuel filler door (1) out to fully open.
5. To remove the fuel tank cap (2), turn it counterclockwise. You may hear a hissing noise as the pressure inside the tank equalizes.
6. Place the cap on the fuel filler door.

#### **i** Information

If the fuel filler door does not open because ice has formed around it, tap lightly or push on the door to break the ice and release the door. Do not pry on the door. If necessary, spray around the door with an approved de-icer fluid (do not use radiator anti-freeze) or move the vehicle to a warm place and allow the ice to melt.

### ***Closing the fuel filler door***

1. To install the fuel tank cap, turn it clockwise until it “clicks” one time.
2. Close the fuel filler door until it is latched securely.

### ***i* Information**

The fuel filler door will not close if the driver's door is locked. If you lock the driver's door while fueling, unlock it before closing the fuel filler door.

### **WARNING**

Gasoline is highly flammable and explosive. Failure to follow these guidelines may result in **SERIOUS INJURY** or **DEATH**:

- Read and follow all warnings posted at the gas station.
- Before refueling, note the location of the Emergency Gasoline Shut-Off, if available, at the gas station.

(Continued)

### **(Continued)**

- Before touching the fuel nozzle, you should eliminate the potential build-up of static electricity by touching a metal part of the vehicle, a safe distance away from the fuel filler neck, nozzle, or other gas source, with your bare hand.
- Do not use cellular phones while refueling. Electric current and/or electronic interference from cellular phones can potentially ignite fuel vapors and cause a fire.
- Do not get back into a vehicle once you have begun refueling. You can generate a build-up of static electricity by touching, rubbing or sliding against any item or fabric capable of producing static electricity.

(Continued)

### **(Continued)**

Static electricity discharge can ignite fuel vapors causing a fire. If you must re-enter the vehicle, you should once again eliminate potentially dangerous static electricity discharge by touching a metal part of the vehicle, away from the fuel filler neck, nozzle or other gasoline source, with your bare hand.

- When refueling, always move the shift lever to 1st gear when the vehicle is parked on a uphill and to R (Reverse) on a downhill, set the parking brake, and place the ignition switch to the LOCK/OFF position. Sparks produced by electrical components related to the engine can ignite fuel vapors causing a fire.

(Continued)

(Continued)

- When using an approved portable fuel container, be sure to place the container on the ground prior to refueling. Static electricity discharge from the container can ignite fuel vapors causing a fire. Once refueling has begun, contact between your bare hand and the vehicle should be maintained until the filling is complete.
- Use only approved portable plastic fuel containers designed to carry and store gasoline.
- Do not use matches or a lighter and do not smoke or leave a lit cigarette in your vehicle while at a gas station, especially during refueling.
- Do not over-fill or top-off your vehicle tank, which can cause gasoline spillage.

(Continued)

(Continued)

- If a fire breaks out during refueling, leave the vicinity of the vehicle, and immediately contact the manager of the gas station and then contact the local fire department. Follow any safety instructions they provide.
- If pressurized fuel sprays out, it can cover your clothes or skin and thus subject you to the risk of fire and burns. Always remove the fuel cap carefully and slowly. If the cap is venting fuel or if you hear a hissing sound, wait until the condition stops before completely removing the cap.
- Always check that the fuel cap is installed securely to prevent fuel spillage in the event of an accident.

### Information

Make sure to refuel your vehicle according to the "Fuel Requirements" suggested in the Introduction chapter.

#### **NOTICE**

- Do not spill fuel on the exterior surfaces of the vehicle. Any type of fuel spilled on painted surfaces may damage the paint.
- If the fuel filler cap requires replacement, use only a genuine HYUNDAI cap or the equivalent specified for your vehicle. An incorrect fuel filler cap can result in a serious malfunction of the fuel system or emission control system.

## INSTRUMENT CLUSTER



1. Variable LED tachometer
2. Speedometer
3. Engine coolant temperature gauge
4. Fuel gauge
5. Warning and indicator lights
6. LCD display (including Trip computer)

**The actual cluster in the vehicle may differ from the illustration.  
For more details, refer to the "Gauges and Meters" in this chapter.**

OPDEN047101

### Instrument cluster control

#### Instrument panel illumination

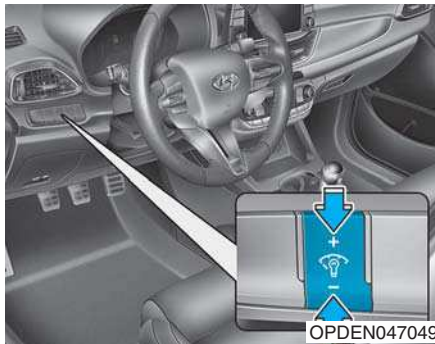

When the vehicle's position lights or headlamps are on, press the illumination control button to adjust the brightness of the instrument panel illumination.

When pressing the illumination control button, the interior switch illumination intensity is also adjusted.

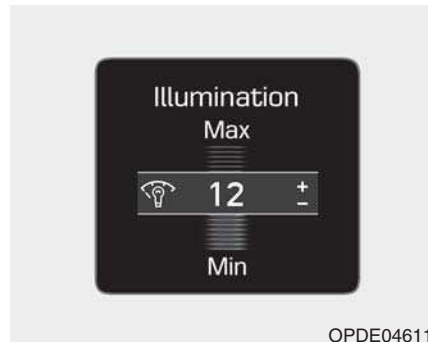
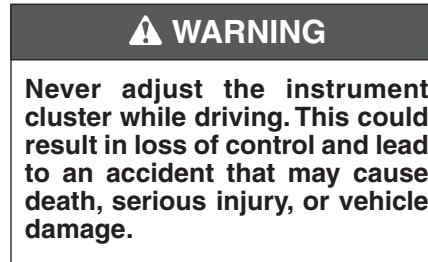

- The brightness of the instrument panel illumination is displayed.
- If the brightness reaches the maximum or minimum level, an alarm will sound.

### Gauges and meters

#### Speedometer



The speedometer indicates the speed of the vehicle and is calibrated in kilometers per hour (km/h) and/or miles per hour (MPH).

### Variable LED tachometer



The tachometer indicates the approximate number of engine revolutions per minute (rpm).

Use the tachometer to select the correct shift points and to prevent lugging and/or over-revving the engine.



The yellow and red LEDs show the range of recommended engine operation speed. As the engine oil temperature warms up, the recommended engine speed range also extends.

Avoid driving with engine speeds in the yellow and red warning fields.

In particular, do not drive with the engine speed in the red warning field. Doing so may damage the engine.

### Engine coolant temperature gauge



This gauge indicates the temperature of the engine coolant when the ignition switch is in the ON position.

#### NOTICE

**If the gauge pointer moves beyond the normal range area toward the "130" position, it indicates overheating that may damage the engine.**

**Do not continue driving with an overheated engine. If your vehicle overheats, refer to "If the Engine Overheats" in chapter 6.**

**⚠ WARNING**

Never remove the coolant cap when the engine is hot. The engine coolant is under pressure and could cause severe burns. Wait until the engine is cool before adding coolant to the reservoir.

**Fuel gauge**



This gauge indicates the approximate amount of fuel remaining in the fuel tank.

**i Information**

- The fuel tank capacity is given in chapter 8.
- The fuel gauge is supplemented by a low fuel warning light, which will illuminate when the fuel tank is nearly empty.
- On inclines or curves, the fuel gauge pointer may fluctuate or the low fuel warning light may come on earlier than usual due to the movement of fuel in the tank.

**⚠ WARNING**

Running out of fuel can expose vehicle occupants to danger. You must stop and obtain additional fuel as soon as possible after the warning light comes on or when the gauge indicator comes close to the "0" level.

**NOTICE**

Avoid driving with an extremely low fuel level. Running out of fuel could cause the engine to misfire damaging the catalytic converter.

### Outside temperature gauge

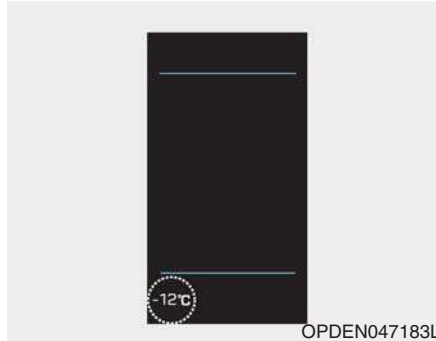

This gauge indicates the current outside air temperatures either in Celsius (°C) or Fahrenheit.

- Temperature range : -40°C ~ 60°C (-104°F ~ 140°F)

The outside temperature on the display may not immediately change like a general thermometer not to distract the driver.

The temperature unit (from °C to °F or from °F to °C) can be changed by:

- User Settings mode in the Cluster : You can change the temperature unit in the "Other Features - Temperature unit" .

- Automatic climate control system : While pressing the OFF button, press the AUTO button for 3 seconds or more.

The temperature unit on both the cluster LCD display and the climate control screen will change.

### Odometer

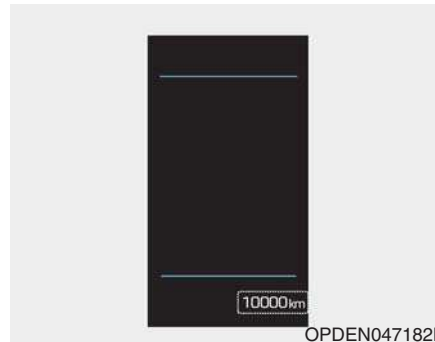

The odometer indicates the total distance that the vehicle has been driven and should be used to determine when periodic maintenance should be performed.

### Distance to empty



- The distance to empty is the estimated distance the vehicle can be driven with the remaining fuel.
- If the estimated distance is below 1 km (1 mi.), the trip computer will display "---" as distance to empty.



### **i** Information

- If the vehicle is not on level ground or the battery power has been interrupted, the distance to empty function may not operate correctly.
- The distance to empty may differ from the actual driving distance as it is an estimate of the available driving distance.
- The trip computer may not register additional fuel if less than 6 liters (1.6 gallons) of fuel are added to the vehicle.
- The distance to empty may vary significantly based on driving conditions, driving habits, and condition of the vehicle.

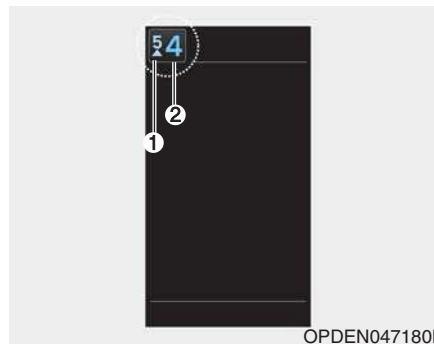

### Manual transmission shift indicator



OPDEN047180L

1. This indicator informs which gear is recommended while driving, to save fuel.
2. This indicator informs the current gear engaged (available only while driving).

For example

-  : Indicates that shifting up to the 3rd gear is recommended (currently the shift lever is in the 2nd or 1st gear).
-  : Indicates that shifting down to the 3rd gear is recommended (currently the shift lever is in the 4th, 5th, or 6th gear).

When the system is not working properly, the indicator is not displayed.

### **i** Information

The recommended gear (1) may vary according to which drive mode is selected.

### Shift lights



OPDEN047149

The number of LEDs illuminated indicates the relevant engine speed. Different colored LEDs will be illuminated as engine speed nears the maximum allowed speed. When all 5 LEDs start blinking, it indicates the best time to initiate upshift operation. Do not wait any further to shift.

You may select in which mode to display the gear shift indicator in the User Settings mode.

Go to 'User Settings → Convenience → Shift recommendation light → ECO/NORMAL/SPORT/N/CUSTOM'.

Each gear and drive mode has different LED operation range. In SPORT mode and N mode, LED operation is broader than NORMAL mode and ECO mode to further support the driver under sporty and track driving conditions.

## Warning and indicator lights

### Information

**Make sure that all warning lights are OFF after starting the engine. If any light is still ON, this indicates a situation that needs attention.**

### *Air Bag Warning Light*



**This warning light illuminates:**

- When you turn the ignition switch or the Engine Start/Stop button to the ON position.
  - It illuminates for approximately 6 seconds and then goes off.
- When there is a malfunction with the SRS.

In this case, we recommend that you have the vehicle inspected by an authorized HYUNDAI dealer.

### *Seat Belt Warning Light*



This warning light informs the driver that the seat belt is not fastened.

**For more details, refer to “Seat Belts” in chapter 2.**

### *Parking Brake & Brake Fluid Warning Light*



**This warning light illuminates:**

- When you set the ignition switch or the Engine Start/Stop button to the ON position.
  - It illuminates for approximately 3 seconds
  - It remains on if the parking brake is applied.
- When the parking brake is applied.
- When the brake fluid level in the reservoir is low.
  - If the warning light illuminates with the parking brake released, it indicates the brake fluid level in the reservoir is low.

**If the brake fluid level in the reservoir is low:**

1. Drive carefully to the nearest safe location and stop your vehicle.
2. With the engine stopped, check the brake fluid level immediately and add fluid as required (**For more details, refer to “Brake Fluid” in chapter 7**). After adding brake fluid, check all brake components for fluid leaks. If a brake fluid leak is found, or if the warning light remains on, or if the brakes do not operate properly, do not drive the vehicle. We recommend that you have the vehicle inspected by an authorized HYUNDAI dealer.

### Dual-diagonal braking system

Your vehicle is equipped with dual-diagonal braking systems. This means you still have braking on two wheels even if one of the dual systems should fail.

With only one of the dual systems working, more than normal pedal travel and greater pedal pressure are required to stop the vehicle.

Also, the vehicle will not stop in as short a distance with only a portion of the brake system working.

If the brakes fail while you are driving, shift to a lower gear for additional engine braking and stop the vehicle as soon as it is safe to do so.

### WARNING

#### **Parking Brake & Brake Fluid Warning Light**

**Driving the vehicle with a warning light ON is dangerous. If the Parking Brake & Brake Fluid Warning Light illuminates with the parking brake released, it indicates that the brake fluid level is low.**

**In this case, we recommend that you have the vehicle inspected by an authorized HYUNDAI dealer.**

### **Anti-lock Brake System (ABS) Warning Light**



**This warning light illuminates:**

- When you set the ignition switch or the Engine Start/Stop button to the ON position.
  - It illuminates for approximately 3 seconds and then goes off.
- When there is a malfunction with the ABS (The normal braking system will still be operational without the assistance of the anti-lock brake system).

In this case, we recommend that you have the vehicle inspected by an authorized HYUNDAI dealer.

### Electronic Brake Force Distribution (EBD) System Warning Light



These two warning lights illuminate at the same time while driving:

- When the ABS and regular brake system may not work normally. In this case, we recommend that you have the vehicle inspected by an authorized HYUNDAI dealer.

#### WARNING

#### Electronic Brake Force Distribution (EBD) System Warning Light

When both ABS and Parking Brake & Brake Fluid Warning Lights are on, the brake system will not work normally and you may experience an unexpected and dangerous situation during sudden braking.

(Continued)

(Continued)

In this case, avoid high speed driving and abrupt braking.

We recommend you have the vehicle inspected by an authorized HYUNDAI dealer as soon as possible.

#### Information - Electronic Brake Force Distribution (EBD) System Warning Light

When the ABS Warning Light is on or both ABS and Parking Brake & Brake Fluid Warning Lights are on, the speedometer, odometer, or tripmeter may not work. Also, the EPS Warning Light may illuminate and the steering effort may increase or decrease.

In this case, we recommend you have the vehicle inspected by an authorized HYUNDAI dealer as soon as possible.

### Electric Power Steering (EPS) Warning Light



This warning light illuminates:

- When you set the ignition switch or the Engine Start/Stop button to the ON position.
  - It illuminates for approximately 3 seconds and then goes off.
- When there is a malfunction with the EPS.

In this case, we recommend that you have the vehicle inspected by an authorized HYUNDAI dealer.

### Malfunction Indicator Lamp (MIL)

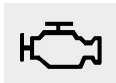

This warning light illuminates:

- When you set the ignition switch or the Engine Start/Stop button to the ON position.
  - It illuminates for approximately 3 seconds and then goes off.
- When there is a malfunction with the emission control system.

In this case, we recommend that you have the vehicle inspected by an authorized HYUNDAI dealer.

#### NOTICE

**Driving with the Malfunction Indicator Lamp (MIL) on may cause damage to the emission control system which could affect drivability and/or fuel economy.**

#### NOTICE - Gasoline Engine

**If the Malfunction Indicator Lamp (MIL) illuminates, potential catalytic converter damage is possible which could result in loss of engine power.**

**In this case, we recommend that you have the vehicle inspected by an authorized HYUNDAI dealer as soon as possible.**

### Charging System Warning Light



This warning light illuminates:

- When there is a malfunction with either the alternator or electrical charging system.

**If there is a malfunction with either the alternator or electrical charging system:**

1. Drive carefully to the nearest safe location and stop your vehicle.
2. Turn the engine off and check the alternator drive belt for looseness or breakage.

If the belt is adjusted properly, there may be a problem in the electrical charging system.

In this case, we recommend that you have the vehicle inspected by an authorized HYUNDAI dealer as soon as possible.

## Engine Oil Pressure Warning Light



This warning light illuminates:

- When the engine oil pressure is low.

If the engine oil pressure is low:

1. Drive carefully to the nearest safe location and stop your vehicle.
2. Turn the engine off and check the engine oil level (**For more details, refer to “Engine Oil” in chapter 7**). If the level is low, add oil as required. If the warning light remains on after adding oil or if oil is not available, we recommend that you have the vehicle inspected by an authorized HYUNDAI dealer as soon as possible.

### NOTICE

- If the engine does not stop immediately after the Engine Oil Pressure Warning Light is illuminated, severe damage could result.
- If the warning light stays on while the engine is running, it indicates that there may be serious engine damage or malfunction. In this case:
  1. Stop the vehicle as soon as it is safe to do so.
  2. Turn off the engine and check the oil level. If the oil level is low, fill the engine oil to the proper level.
  3. Start the engine again. If the warning light stays on after the engine is started, turn the engine off immediately. In this case, we recommend that you have the vehicle inspected by an authorized HYUNDAI dealer.

## Low Fuel Level Warning Light



This warning light illuminates:

- When the fuel tank is nearly empty. Add fuel as soon as possible.

### NOTICE

Driving with the Low Fuel Level warning light on or with the fuel level below “0” can cause the engine to misfire and damage the catalytic converter (if equipped).

### Master Warning Light



#### This indicator light illuminates:

- When there is a malfunction in the below systems.
  - LED head lamp malfunction
  - Smart high beam malfunction (if equipped)
  - Autonomous Emergency Braking (AEB) malfunction (if equipped)
  - Speed Limit Information Function (SLIF) malfunction (if equipped)

To identify the details of the warning, look at the LCD display.

### Low Tire Pressure Warning Light (if equipped)



#### This warning light illuminates:

- When you set the ignition switch or Engine Start/Stop button to the ON position.
  - It illuminates for approximately 3 seconds and then goes off.
- When one or more of your tires are significantly underinflated (The location of the underinflated tires are displayed on the LCD display).

**For more details, refer to “Tire Pressure Monitoring System (TPMS)” in chapter 6.**

This warning light remains on after blinking for approximately 60 seconds or repeatedly blinks on and off at approximately 3 second intervals:

- When there is a malfunction with the TPMS.

In this case, we recommend that you have the vehicle inspected by an authorized HYUNDAI dealer as soon as possible.

**For more details, refer to “Tire Pressure Monitoring System (TPMS)” in chapter 6.**

### WARNING

#### Safe Stopping

- The TPMS cannot alert you to severe and sudden tire damage caused by external factors.
- If you notice any vehicle instability, immediately take your foot off the accelerator pedal, apply the brakes gradually with light force, and slowly move to a safe position off the road.

### **Electronic Stability Control (ESC) Indicator Light (if equipped)**



#### **This indicator light illuminates:**

- When you set the ignition switch or the Engine Start/Stop button to the ON position.
  - It illuminates for approximately 3 seconds and then goes off.
- When there is a malfunction with the ESC system.

In this case, we recommend that you have the vehicle inspected by an authorized HYUNDAI dealer.

#### **This indicator light blinks:**

- While the ESC is operating.

**For more details, refer to “Electronic Stability Control (ESC)” in chapter 5.**

### **Electronic Stability Control (ESC) OFF Indicator Light (if equipped)**



#### **This indicator light illuminates:**

- When you set the ignition switch or the Engine Start/Stop button to the ON position.
  - It illuminates for approximately 3 seconds and then goes off.
- When you deactivate the ESC system by pressing the ESC OFF button.

**For more details, refer to “Electronic Stability Control (ESC)” in chapter 5.**

### **ECS SPORT Indicator Light**



#### **This indicator light illuminates:**

- When ESC SPORT is activated.

**For more details, refer to “Electronic Stability Control” in chapter 5.**

### **AUTO STOP Indicator Light (if equipped)**



#### **This indicator light illuminates:**

- When the engine enters the Idle Stop mode of the ISG (Idle Stop and Go) system.

#### **This indicator light blinks:**

- When the automatic starting occurs, the AUTO STOP indicator on the cluster will blink for 5 seconds.

**For more details, refer to the “ISG (Idle Stop and Go) system” in chapter 5.**

### ***i* Information**

When the engine automatically starts by the ISG system, some warning lights (ABS, ESC, ESC OFF, EPS or Parking brake warning light) may turn on for a few seconds.

This happens because of low battery voltage. It does not mean the system has malfunctioned.



### **Immobilizer Indicator Light (without smart key) (if equipped)**



#### **This indicator light illuminates:**

- When the vehicle detects the immobilizer in the key with the ignition switch in the ON position.
  - At this time, you can start the engine.
  - The indicator light goes off after starting the engine.

#### **This indicator light blinks:**

- When there is a malfunction with the immobilizer system.

In this case, we recommend that you have the vehicle inspected by an authorized HYUNDAI dealer.

### **Immobilizer Indicator Light (with smart key) (if equipped)**



#### **This indicator light illuminates for up to 30 seconds:**

- When the vehicle detects the smart key in the vehicle with the Engine Start/Stop button in the ACC or ON position.
  - At this time, you can start the engine.
  - The indicator light goes off after starting the engine.

#### **This indicator light blinks for a few seconds:**

- When the smart key is not in the vehicle.
  - At this time, you cannot start the engine.

#### **This indicator light illuminates for 2 seconds and goes off:**

- If the smart key is in the vehicle and the Engine Start/Stop button is ON, but the vehicle cannot detect the smart key.

In this case, we recommend that you have the vehicle inspected by an authorized HYUNDAI dealer.

#### **This indicator light blinks:**

- When the battery voltage of the smart key is low.
  - At this time, you cannot start the engine. However, you can start the engine if you press the Engine Start/Stop button with the smart key. **(For more details, refer to "Starting the Engine" in chapter 5).**
- When there is a malfunction with the immobilizer system.

In this case, we recommend that you have the vehicle inspected by an authorized HYUNDAI dealer.

### **Turn Signal Indicator Light**

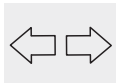

#### **This indicator light blinks:**

- When you operate the turn signals.

If any of the following occur, there may be a malfunction with the turn signal system.

- The turn signal indicator light illuminates but does not blink
- The turn signal indicator light blinks rapidly
- The turn signal indicator light does not illuminate at all

If any of these conditions occur, we recommend that you have your vehicle inspected by an authorized HYUNDAI dealer.

### **Low Beam Indicator Light (if equipped)**



#### **This indicator light illuminates:**

- When the headlights are on.

### **High Beam Indicator Light**



#### **This indicator light illuminates:**

- When the headlamps are on and in the high beam position.
- When the turn signal lever is pulled into the Flash-to-Pass position.

### **Smart High Beam Indicator Light (if equipped)**



#### **This warning light illuminates:**

- When the high-beam is on with the light switch in the AUTO light position.
- If your vehicle detects oncoming or preceding vehicles, the Smart High Beam system will switch the high beam to low beam automatically.

**For more details, refer to "Smart High Beam" in this chapter.**

### **Light ON Indicator Light**



#### **This indicator light illuminates:**

- When the tail lights or headlamps are on.

### **Rear Fog Indicator Light**



#### **This indicator light illuminates:**

- When the rear fog lights are on.

### **LED Headlamp Warning Light**



#### **This warning light illuminates:**

- When you turn the ignition switch or the Engine Start/Stop button to the ON position.
- When there is a malfunction with the LED headlamp.

In this case, we recommend that you have the vehicle inspected by an authorized HYUNDAI dealer.

#### **This warning light blinks:**

When there is a malfunction with a LED headlamp related part.

In this case, we recommend that you have the vehicle inspected by an authorized HYUNDAI dealer.

#### **NOTICE**

**Continuous driving with the LED Headlamp Warning Light on or blinking can reduce LED headlamp life.**

### **Cruise Indicator Light (if equipped)**



#### **This indicator light illuminates:**

- When the cruise control system is enabled.

**For more details, refer to "Cruise Control System" in chapter 5.**

### **Cruise SET Indicator Light (if equipped)**



#### **This indicator light illuminates:**

- When the cruise control speed is set.

**For more details, refer to "Cruise Control System" in chapter 5.**

### **SPORT Mode Indicator Light**



#### **This indicator light illuminates:**

- When you select "SPORT" mode as drive mode.

**For more details, refer to "Drive Mode Integrated Control System" in chapter 5.**

### ***ECO Mode Indicator Light***



#### **This indicator light illuminates:**

- When you select "ECO" mode as drive mode.

**For more details, refer to "Drive Mode Integrated Control System" in chapter 5.**

### ***N Mode Indicator Light***



#### **This indicator light illuminates:**

- When you select "N" mode as drive mode.

**For more details, refer to "Drive Mode Integrated Control System" in chapter 5.**

### ***CUSTOM Mode Indicator Light***



#### **This indicator light illuminates:**

- When you select "CUSTOM" mode as drive mode.

**For more details, refer to "Drive Mode Integrated Control System" in chapter 5.**

### ***REV (Rev Matching) Indicator Light***



#### **This indicator light illuminates:**

[White] When Rev Matching is turned on in NORMAL mode.

[Yellow] When Rev Matching is turned on in SPORT mode.

[Red] When Rev Matching is turned on in N mode.

**For more details, refer to "Rev Matching" in chapter 5.**

### **Autonomous Emergency Braking (AEB) Warning light (if equipped)**



#### **This indicator light illuminates:**

- When you set the ignition switch or Engine Start/Stop button to the ON position.
  - It illuminates for approximately 3 seconds and then goes off.
- When there is a malfunction with the AEB.

In this case, we recommend that you have the vehicle inspected by an authorized HYUNDAI dealer.

**For more details, refer to "Autonomous Emergency Braking (AEB)" in chapter 5.**

### **Lane Departure Warning System (LDWS) Indicator Light (if equipped)**



#### **This indicator light illuminates:**

- [Green] When you activate the lane departure warning system.
- [White] When system operating conditions are not satisfied.
- [Yellow] When there is a malfunction with the lane departure warning system.

In this case, we recommend that you have the vehicle inspected by an authorized HYUNDAI dealer.

**For more details, refer to "Lane Departure Warning System (LDWS)" in chapter 5.**

### **Lane Keeping Assist System (LKAS) Indicator Light (if equipped)**



#### **This indicator light illuminates:**

- [Green] When the system operating conditions are satisfied.
- [White] The system operating conditions are not satisfied.
- [Yellow] When there is a malfunction with the lane keeping assist system.

In this case, we recommend you to have your vehicle inspected by an authorized HYUNDAI dealer.

**For more details, refer to "Lane Keeping Assist System (LKAS)" in chapter 5.**

### **Icy Road Warning Light (if equipped)**



This warning light is to warn the driver the road may be icy.

When the temperature on the outside temperature gauge is approximately below 4°C (40°F), the Icy Road Warning Light and Outside Temperature Gauge blinks and then illuminates. Also, the warning chime sounds 1 time.

#### ***i* Information**

**If the icy road warning light appears while driving, you should drive more attentively and safely refraining from over-speeding, rapid acceleration, sudden braking or sharp turning, etc.**

### **LCD display messages**

#### ***Low Key Battery (for smart key system)***

This warning message is displayed if the battery of the smart key is discharged while changing the Engine Start/Stop button to the OFF position.

#### ***Press START while turning wheel (for smart key system)***

This warning message is displayed if the steering wheel does not unlock normally when the Engine Start/Stop button is pressed.

You should press the Engine Start/Stop button while turning the steering wheel right and left.

#### ***Steering wheel unlocked (for smart key system)***

This warning message is displayed if the steering wheel is not locked while the Engine Start/Stop button changes to the OFF position.

#### ***Check Steering Wheel Lock System (for smart key system)***

This warning message is displayed if the steering wheel does not lock normally while the Engine Start/Stop button changes to the OFF position.

#### ***Press clutch pedal to start engine (for smart key system)***

This warning message is displayed if the Engine Start/Stop button is in the ACC position twice by pressing the button repeatedly without depressing the clutch pedal.

Depress the clutch pedal to start the engine.

#### ***Key not in vehicle (for smart key system)***

This warning message is displayed if the smart key is not in the vehicle when you press the Engine Start/Stop button.

When attempting to start the vehicle always have the smart key with you.

### **Key not detected (for smart key system)**

This warning message is displayed if the smart key is not detected when you press the Engine Start/Stop button.

### **Press START button with key (for smart key system)**

This warning message is displayed if you press the Engine Start/Stop button while the warning message “Key not detected” is displayed.

At this time, the immobilizer indicator light blinks.

### **Press START button again (for smart key system)**

This message is displayed if you were unable to start the vehicle when the Engine Start/Stop button was pressed.

If this occurs, attempt to start the engine by pressing the Engine Start/Stop button again.

If the warning message appears each time you press the Engine Start/Stop button, we recommend that you have your vehicle inspected by an authorized HYUNDAI dealer.

### **Door, Hood, Tailgate open**

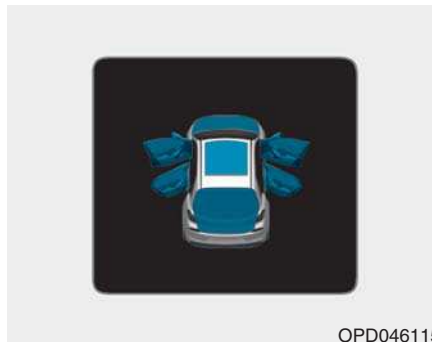

This warning is displayed indicating which door, or hood, or tailgate is open.

#### **⚠ CAUTION**

**Before driving the vehicle, you should confirm that the door/hood/tailgate is fully closed. Also, check there is no door/hood/tailgate open warning light or message displayed on the instrument cluster.**

### **Sunroof open (if equipped)**

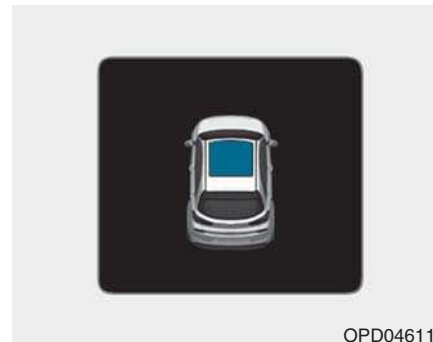

This warning is displayed if you turn off the engine when the sunroof is open.

Close the sunroof securely when leaving your vehicle.

### Lights mode

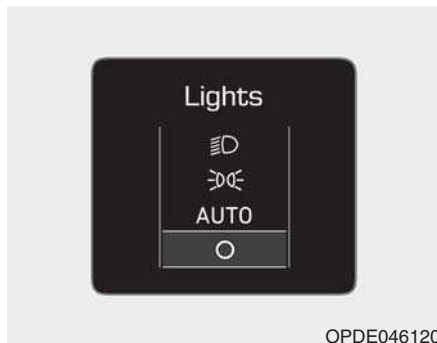

This indicator displays which exterior light is selected using the lighting control.

### Wiper mode

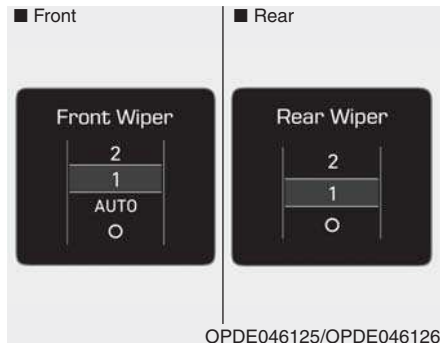

This indicator displays which wiper speed is selected using the wiper control.

### Low Pressure (if equipped)



This warning message is displayed if the tire pressure is low. The corresponding tire on the vehicle will be illuminated.

**For more details, refer to "Tire Pressure Monitoring System (TPMS)" in chapter 6.**



### Turn on FUSE SWITCH

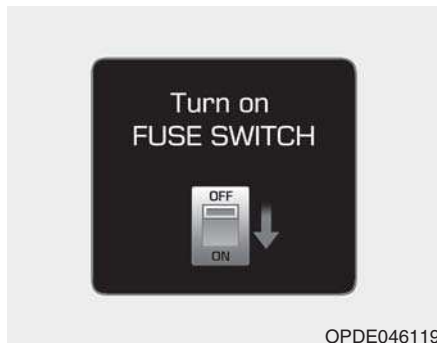

This warning message is displayed if the fuse switch located on the fuse box under the steering wheel is OFF. You should turn the fuse switch on.

**For more details, refer to “Fuses” in chapter 7.**

### Heated Steering Wheel turned off (if equipped)

This message is displayed if you turn off the heated steering wheel.

**For more details, refer to “Heated Steering Wheel” in this chapter.**

### Low Washer Fluid (if equipped)

This warning message is displayed if the washer fluid level in the reservoir is nearly empty.

Have the washer fluid reservoir refilled.

### Low Fuel

This warning message is displayed if the fuel tank is almost out of fuel.

When this message is displayed, the low fuel level warning light in the cluster will come on.

It is recommended to look for the nearest fueling station and refuel as soon as possible.

Add fuel as soon as possible.

### Engine has overheated (if equipped)

This warning message is displayed when the engine coolant temperature is above 120°C (248°F). This means that the engine is overheated and may be damaged.

**If your vehicle is overheated, refer to “Overheating” in chapter 6.**

### Check headlight (if equipped)

This warning message is displayed if the headlamps are not operating properly. A headlamp bulb may need to be replaced.

### Information

**Make sure to replace the burned out bulb with a new one of the same wattage rating.**

**Check headlamp LED  
(if equipped)**

This warning message is displayed if there is a problem with the LED headlamps. We recommend that you have the vehicle inspected by an authorized HYUNDAI dealer.

**Check headlamp FAN  
(if equipped)**

This warning message is displayed if there is a problem with the headlamps fan. We recommend that you have the vehicle inspected by an authorized HYUNDAI dealer.

**Check Smart High Beam  
System (if equipped)**

This warning message is displayed if there is a problem with the Smart High Beam System. We recommend that you have the vehicle inspected by an authorized HYUNDAI dealer.

**For more details, refer to “Smart High Beam System” in chapter 3.**

**Check AEB system (if equipped)**

This warning message is displayed if there is a malfunction with the Autonomous Emergency Braking (AEB) system. We recommend that you have the vehicle inspected by an authorized HYUNDAI dealer.

**For more details, refer to “Autonomous Emergency Braking (AEB) system” in chapter 5.**

**Check LDWS (if equipped)**

This warning message is displayed if there is a problem with the Lane Departure Warning System (LDWS). We recommend that you to have the vehicle inspected by an authorized HYUNDAI dealer.

**For more details, refer to “Lane Departure Warning System (LDWS)” in chapter 5.**

**Check LKAS (if equipped)**

This warning message is displayed if there is a problem with the Lane Keeping Assist System (LKAS). We recommend that you have the vehicle inspected by an authorized HYUNDAI dealer.

**For more details, refer to “Lane Keeping Assist System (LKAS)” in chapter 5.**

**Check Driver Attention Alert  
(if equipped)**

This warning message is displayed if there is a problem with the Driver Attention Alert System. We recommend that you have the vehicle inspected by an authorized HYUNDAI dealer.

**For more details, refer to “Driver Attention Alert (DAA)” in chapter 5.**

### ***Tyre size mismatch.***

#### ***Check tyre sizes***

This warning message is displayed when different tires (size, type, etc.) are detected between front and rear. To use the Electronic Limited Slip Differential, equip the vehicle with the same tires on front and rear.

**For more details, refer to “Electronic Limited Slip Differential” in chapter 5.**

#### ***Check limited slip differential***

This warning message is displayed if there is a problem with the Limited Slip Differential system.

We recommend that you have the vehicle inspected by an authorized HYUNDAI dealer.

**For more details, refer to “Electronic Limited Slip Differential” in chapter 5.**

### ***Check ECS***

This warning message is displayed if there is a problem with the Electronic Control Suspension (ECS) system.

We recommend that you have the vehicle inspected by an authorized HYUNDAI dealer.

**For more details, refer to “Electronic Control Suspension (ECS)” in chapter 5.**

### ***Beware of engine damage when shifting while in high RPM***

If transmission input rpm is too high (over rev limit) due to shifting, a warning message will appear and a warning chime will sound.

**For more details, refer to “Rev Matching” in chapter 5.**



## LCD DISPLAY

### LCD display control







OPDEN047404

The LCD display modes can be changed by using the control buttons.

- (1)  : MODE button for changing modes
- (2)  ,  : MOVE switch for changing items
- (3) OK : SELECT/RESET button for setting or resetting the selected item

### LCD display modes

Modes	Symbol	Explanation
Trip Computer		This mode displays driving information such as the tripmeter, fuel economy, etc. For more details, refer to "Trip Computer" in this chapter.
Turn By Turn (TBT)		This mode displays the state of the navigation.
Assist		<p>This mode displays the state of :</p> <ul style="list-style-type: none"> <li>- Oil Temperature, Torque, Turbo Boost</li> <li>- Lap Timer</li> <li>- G-Force</li> <li>- Lane Keeping Assist System (LKAS)</li> <li>- Lane Departure Warning System (LDWS)</li> <li>- Driver Attention Alert (DAA)</li> <li>- Tire Pressure</li> </ul> <p><b>For more details, refer to "Lane Departure Warning System (LDWS)", "Lane Keeping Assist System (LKAS)", "Driver Attention Alert (DAA)" in chapter 5 and "Tire Pressure Monitoring System (TPMS)" in chapter 6.</b></p>
User Settings		In this mode, you can change settings of the doors, lamps, etc.
Warning		This mode displays warning messages related to the Autonomous Emergency Braking system, etc.

The information provided may differ depending on which functions are applicable to your vehicle.

### **Settings available after engaging parking brake**



This warning message illuminates if you try to select an item from the User Settings mode while driving. For your safety, change the User Settings after engaging the parking brake.

### **Quick guide (Help, if equipped)**

This mode provides quick guides for the systems in the User Settings mode.

Select an item, press and hold the OK button.

**For more details about each system, refer to this Owner's Manual.**

### **Trip computer mode**

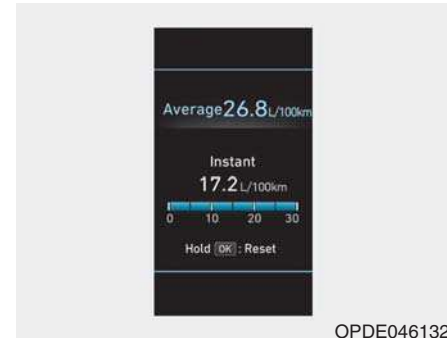

The trip computer mode displays information related to vehicle driving parameters including fuel economy, tripmeter information and vehicle speed.

**For more details, refer to "Trip Computer" in this chapter.**

### Turn By Turn (TBT) mode

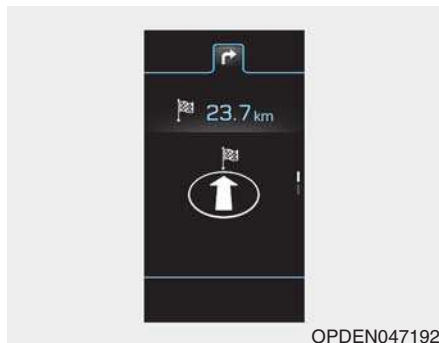

This mode displays the state of the navigation.

### Assist mode

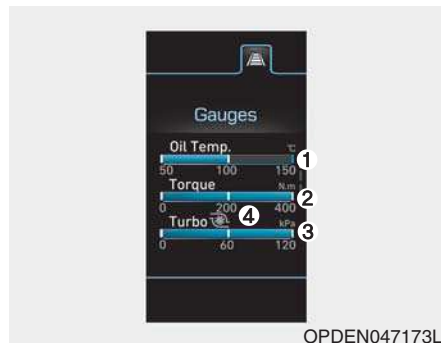

#### Gauges

This mode displays information related to your engine such as engine oil temperature (1), current torque (2) and boost pressure (3) along with an overboost indicator (4).



#### Lap timer

- (1) Total time
- (2) Best lap
- (3) Current lap

#### To start (a):

Press the OK button shortly on the steering wheel. The lap timer will start counting the current lap (3).

#### To stop (b):

Press and hold the OK button for more than 1 second on the steering wheel while the lap timer is counting the current lap (3).

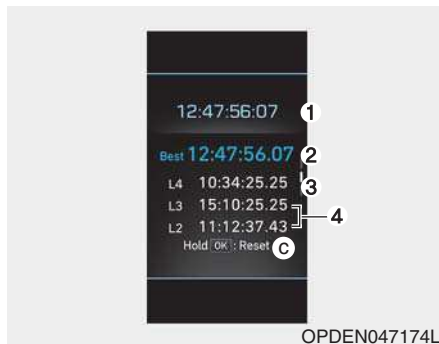

**To reset (c):**

Press and hold the OK button for more than 1 second on the steering wheel when the lap timer has stopped counting the current lap (3). If the OK button is pressed shortly, the lap timer will continue counting from the time it has been stopped.

**To save laps:**

Press the OK button shortly on the steering wheel while the lap timer is counting the current lap (3). The timer can save L1~ L100 (4). The best lap (2) will be displayed automatically.

The saved laps can be reset when the current lap is reset.

To start a new lap press the OKAY button when the current lap is reset.



**G-Force**

This mode displays the force delivered to the vehicle laterally while the vehicle is in motion.



**LKAS/LDWS/DAA**

This mode displays the state of the Cruise Control, Lane Departure Warning System (LDWS)/Lane Keeping Assist System (LKAS) and Driver Attention Alert (DAA).

**For more details, refer to each system information in chapter 5.**





### Tire Pressure

This mode displays information related to Tire Pressure.

**For more details, refer to "Tire Pressure Monitoring System (TPMS)" in chapter 6.**

### Warning message mode



If one of followings occurs, warning messages will be displayed on the LCD display for several seconds.

- LED head lamp malfunction
- Smart high beam malfunction (if equipped)
- Autonomous Emergency Braking (AEB) malfunction (if equipped)
- Speed Limit Information Function (SLIF) malfunction (if equipped)

### User settings mode

In this mode, you can change the settings of the instrument cluster, doors, lamps, etc.

1. Driving Assist
2. Door
3. Lights
4. Sound
5. Convenience
6. Service Interval
7. Other Features
8. Reset

**The information provided may differ depending on which functions are applicable to your vehicle.**

#### 1. Driving Assist

- Lane Keeping Assist System
- Lane Departure Warning/Standard LKA/Active LKA

To adjust the sensitivity of the Lane Keeping Assist System.

**For more details, refer to the "Lane Keeping Assist System" in chapter 5.**

- Driver Attention Alert

- Off/Normal/Early

To adjust the sensitivity of the Driver Attention Alert (DAA).

**For more details, refer to "Driver Attention Alert (DAA)" in chapter 5.**

- Autonomous Emergency Braking

To activate or deactivate the Autonomous Emergency Braking (AEB).

**For more details, refer to "Autonomous Emergency Braking (AEB)" in chapter 5.**

- Forward Collision Warning

- Late/Normal/Early

To adjust the initial warning alert time for Autonomous Emergency Braking system.

**For more details, refer to "Autonomous Emergency Braking (AEB)" in chapter 5.**

- Speed Limit Information Function

To activate or deactivate the Speed Limit Information Function.

**For more details, refer to "Speed Limit Information Function" in chapter 5.**

## 2. Door

- Automatic Lock

- Disable: The auto door lock operation will be canceled.

- Enable on Speed: All doors will be automatically locked when the vehicle speed exceeds 15km/h (9.3mph).

- Automatic Unlock

- Disable: The auto door unlock operation will be canceled.

- Vehicle Off: All doors will be automatically unlocked when the Engine Start/Stop button is set to the OFF position. (if equipped with smart key)

- On Key Out: All doors will be automatically unlocked when the ignition key is removed from the ignition switch. (if equipped with remote key)

- Driver Door Unlock: All doors will be automatically unlocked when the driver's door is opened.

- Horn Feedback

To activate or deactivate the horn feedback.

If the horn feedback is activated, after locking the door by pressing the lock button on the remote key, and pressing it again within 4 seconds, the horn feedback sound will operate once to indicate that all doors are locked. (if equipped with remote key)

### 3. Lights

- One Touch Turn Signal

- Off: The one touch turn signal function will be deactivated.

- 3, 5, 7 Flashes: The turn signal indicator will blink 3, 5, or 7 times when the turn signal lever is moved slightly.

**For more details, refer to "Lighting" in this chapter.**

- Head Lamp Delay

To activate or deactivate the headlamp delay function.

**For more details, refer to "Lighting" in this chapter**

- Welcome Light

To activate or deactivate the welcome light function.

**For more details, refer to "Lighting" in this chapter.**

### 4. Sound

- Park Assist System Volume

- Softer/Louder

To adjust the Park Assist System volume.

- Welcome Sound

To activate or deactivate the welcome sound.

### 5. Convenience

- Seat Easy Access

- Off: The seat easy access function is deactivated.

- Normal/Extended: When you turn off the engine, the driver's seat will automatically move rearward short (Normal) or long (Extended) for you to enter or exit the vehicle more comfortably.

**For more details, refer to "Driver Position Memory System" in this chapter.**

- Wireless Charging System

To activate or deactivate the wireless charging system in the front seat.

**For more details, refer to "Wireless Charging System" in this chapter.**

- Wiper/Lights Display

To activate or deactivate the Wiper/Light mode.

When activated, the LCD display shows the selected Wiper/Light mode whenever you changed the mode.

- Auto Rear Wiper (reverse)

To activate or deactivate the rear wiper while the vehicle is in reverse with the front wiper ON.

- Shift recommendation light

- ECO/NORMAL/SPORT/N/  
CUSTOM

To select in which mode the shift lights are displayed.

## 6. Service Interval

### • Service Interval

To activate or deactivate the service interval function.

### • Adjust Interval

If the service interval menu is activated, you may adjust the time and distance.

### **i** Information

**To use the service interval menu, consult an authorized HYUNDAI dealer.**

If the service interval is activated and the time and distance is adjusted, messages are displayed in the following situations each time the vehicle is turned on.

#### - Service in

: Displayed to inform the driver the remaining mileage and days to service.

#### - Service required

: Displayed when the mileage and days to service has been reached or passed.

### **i** Information

**If any of the following conditions occur, the mileage and number of days to service may be incorrect.**

- The battery cable is disconnected.
- The fuse switch is turned off.
- The battery is discharged.

## 7. Other Features

### • Fuel Economy Auto Reset

- Off: The average fuel economy will not reset automatically whenever refueling.

- After Ignition: When the engine has been OFF for 4 hours or longer the average fuel economy will reset automatically.

- After Refueling: The average fuel economy will reset automatically after adding 6 liters (1.6 gallons) of fuel or more and after driving speed exceeds 1 km/h (1 mph).

**For more details, refer to "Trip Computer" in this chapter.**

### • Fuel economy unit

To select the fuel economy unit. (km/L, L/100, MPG)

### • Temperature unit

To select the temperature unit. (°C, °F)

### • Turbo boost pressure unit

To select the turbo boost pressure unit. (psi/kPa/bar)

### • Torque unit

To select the torques unit. (Nm/lb-ft)

### • Tire pressure unit

To select the tire pressure unit. (psi, kPa, bar)

## 8. Reset

You can reset the menus in the User Settings Mode. All menus in the User Settings Mode are reset to factory settings, except language and service interval.

## TRIP COMPUTER

The trip computer is a microcomputer-controlled driver information system that displays information related to driving.

### **i** Information

Some driving information stored in the trip computer (for example Average Vehicle Speed) resets if the battery is disconnected.

### Trip modes

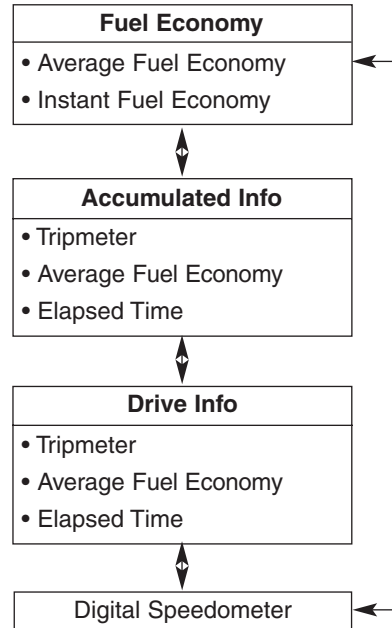

To change the trip mode, toggle the “^, v” switch on the steering wheel.

## Fuel economy

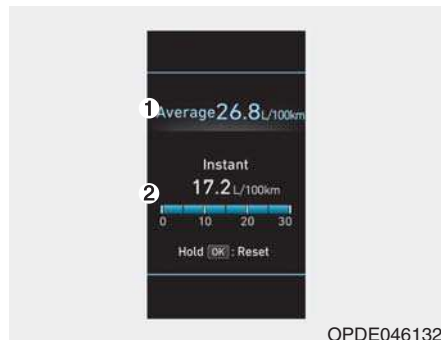

### Average Fuel Economy (1)

- The average fuel economy is calculated by the total driving distance and fuel consumption since the last average fuel economy reset.
- The average fuel economy can be reset both manually and automatically.

### Manual reset

To clear the average fuel economy manually, press the [OK] button on the steering wheel for more than 1 second when the average fuel economy is displayed.

### Automatic reset

To automatically reset the average fuel economy after refueling, select the "Auto Reset" mode in the User Settings menu on the LCD display.

- After Ignition: The average fuel economy will reset automatically whenever it has passed 4 hours after turning OFF the engine.
- After Refueling: The average fuel economy will reset automatically when driving speed exceeds 1 km/h, after adding 6 liters (1.6 gallons) of fuel or more.

### **i** Information

**The average fuel economy may be inaccurate, when the vehicle drives shorter than 300 meters (0.19 miles) after turning ON the Engine Start/Stop button.**

### Instant Fuel Economy (2)

- This mode displays the instant fuel economy during the last few seconds when the vehicle speed is more than 10 km/h (6.2 MPH).

## Accumulated Info display

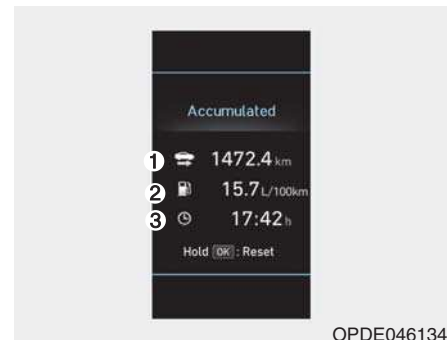

This display shows the accumulated trip distance (1), the average fuel economy (2), and the total driving time (3).

The information is accumulated starting from the last reset.

To manually reset the information, press and hold the OK button when viewing the Accumulated driving info. The trip distance, the average fuel economy, and total driving time will reset simultaneously.

The accumulated driving information will continue to be counted while the engine is still running (for example, when the vehicle is in traffic or stopped at a stop light).

### **i** Information

**The vehicle must be driven for a minimum of 300 meters (0.19 miles) since the last ignition key cycle before the average fuel economy will be recalculated.**

### **Digital Speedometer**

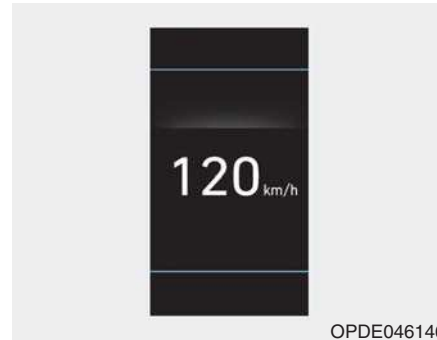

This message shows the speed of the vehicle (km/h, MPH).

## LIGHTING

### Exterior lights

#### Lighting control

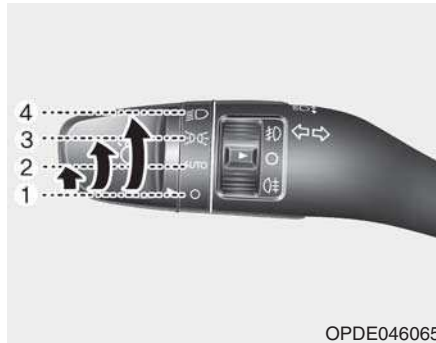

To operate the lights, turn the knob at the end of the control lever to one of the following positions:

- (1) O position
- (2) AUTO light position (if equipped)
- (3) Position lamp position
- (4) Headlamp position



#### AUTO light position (if equipped)

When the light switch is in the AUTO position, the position lamp and headlamp will be turned ON or OFF automatically depending on the amount of light outside the vehicle.

Even with the AUTO light feature in operation, it is recommended to manually turn ON the lamps when driving at night or in a fog, or when you enter dark areas, such as tunnels and parking facilities.

#### NOTICE

- Do not cover or spill anything on the sensor (1) located on the instrument panel.
- Do not clean the sensor using a window cleaner, the cleanser may leave a light film which could interfere with sensor operation.
- If your vehicle has window tint or other types of metallic coating on the front windshield, the AUTO light system may not work properly.





### Position lamp position (D)

The position lamp, license plate lamp and instrument panel lamp are turned ON.



### Headlamp position (D)

The headlamp, position lamp, license plate lamp and instrument panel lamp are turned ON.

### **i** Information

The ignition switch must be in the ON position to turn on the headlamp.

### High beam operation

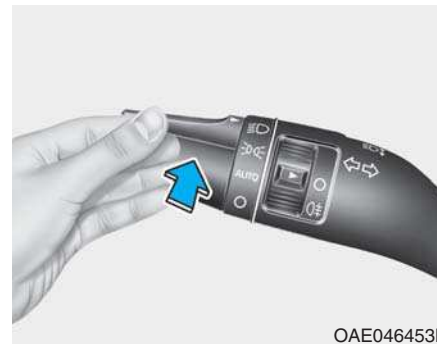

To turn on the high beam headlamp, push the lever away from you. The lever will return to its original position. The high beam indicator will light when the headlamp high beams are switched on.

To turn off the high beam headlamp, pull the lever towards you. The low beams will turn on.

### **⚠** WARNING

**Do not use high beam when there are other vehicles approaching you. Using high beam could obstruct the other driver's vision.**



OAE046455L

To flash the high beam headlamp, pull the lever towards you, then release the lever. The high beams will remain ON as long as you hold the lever towards you.

### Smart high beam (if equipped)



OPDE046057

The Smart High Beam is a system that automatically adjusts the headlamp range (switches between high beam and low beam) according to the brightness of other vehicles and road conditions.

### Operating condition

1. Place the light switch in the AUTO position.
2. Turn on the high beam by pushing the lever away from you.

The smart high beam (  ) indicator will illuminate.

3. The Smart High Beam will turn on when vehicle speed is above 45km/h (25mph).

- If the light switch is pushed away when the Smart High Beam is operating, the Smart High Beam will turn off and the high beam will be on continuously.
- If the light switch is pulled towards you when the high beam is off, the high beam will turn on without the Smart High Beam canceled. When you let go of the light switch, the lever will move to the middle and the high beam will turn off.
- If the light switch is pulled towards you when the high beam is on by the Smart High Beam, the low beam will be on and the Smart High Beam will turn off.
- If the light switch is placed to the headlamp position, the Smart High Beam will turn off and the low beam will be on continuously.

When the Smart High Beam is operating, the high beam switches to low beam in the below conditions.

- When the headlamp of an on-coming vehicle is detected.
- When the tail lamp of a vehicle in front is detected.
- When headlamp/tail lamp of bicycle/motorcycle is detected.
- When the surrounding is bright enough high beams are not needed.
- When streetlights or other lights are detected.
- When the light switch is not in the AUTO position.
- When the Smart High Beam is off.
- When vehicle speed is below 24 km/h (15 mph).

### Warning light and message

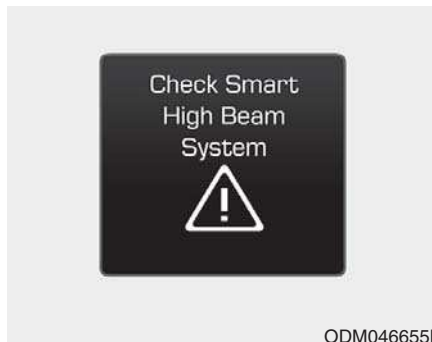

When the Smart High Beam Assist System is not working properly, the warning message will come on for a few second. After the message disappears, the master warning light (⚠) will illuminate.

We recommend that you take your vehicle to an authorized HYUNDAI dealer and have the system checked.

### ⚠ CAUTION

The system may not operate normally in the below conditions.

- When the light from the on-coming or front vehicle is not detected because of lamp damage, hidden from sight, etc.
- When the lamp of the on-coming or front vehicle is covered with dust, snow or water.
- When the light from the on-coming or front vehicle is not detected because of exhaust fumes, smoke, fog, snow, etc.
- When the front window is covered with foreign matter such as ice, dust, fog, or is damaged.

(Continued)

(Continued)

- When there is a similar shaped lamp with the front vehicle's lamps.
- When it is hard to see because of fog, heavy rain or snow.
- When the headlamp is not repaired or replaced at an authorized dealer.
- When headlamp aiming is not properly adjusted.
- When driving on a narrow winding road or rough road.
- When driving downhill or uphill.
- When only part of the vehicle in front is visible on a cross-road or on a corner.
- When there is a traffic light, reflecting sign, flashing sign or mirror.
- When the road conditions are bad such as being wet or covered with snow.

(Continued)

(Continued)

- When the front vehicle's headlamps are off but the fog lamps on.
- When a vehicle suddenly appears from a around a corner.
- When the vehicle is tilted from a flat tyre or being towed.
- When the LDWS (Lane Departure Warning System) or LKAS (Lane Keeping Assist System) warning light illuminates. (if equipped)

### Information

When you replace or reinstall the windshield glass or LDWS/LKAS camera (if equipped), We recommend that you take your vehicle to an authorized HYUNDAI dealer and have the system checked.

### WARNING

- Do not place any accessories, stickers or tint the windshield.
- Have the windshield glass replaced by an authorised dealer.
- Do not remove or impact related parts of the Smart High Beam system.
- Be careful that water doesn't get into the Smart High Beam unit.
- Do not place objects on the instrument panel that reflect light such as mirrors, white paper, etc. The system may malfunction if sunlight is reflected.
- At times, the Smart High Beam system may not work properly, always check the road conditions for your safety. When the system does not operate normally, manually change between the high beam and low beam.

### Turn signals and lane change signals

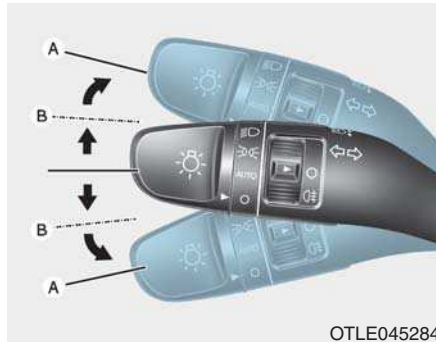

OTLE045284

To signal a turn, push down on the lever for a left turn or up for a right turn in position (A). To signal a lane change, move the turn signal lever slightly and hold it in position (B). The lever will return to the OFF position when released or when the turn is completed.

If an indicator stays on and does not flash or if it flashes abnormally, one of the turn signal bulbs may be burned out and will require replacement.

### One-touch turn signal function

To activate a one-touch turn signal function, move the turn signal lever slightly and then release it. The lane change signals will blink 3, 5 or 7 times.

You can activate/deactivate the One Touch Turn Signal function or choose the number of blinks (3, 5, or 7) from the User Settings mode on the LCD display. **For more details, refer to "LCD Display" in this chapter.**

### Rear fog lamp



OTLE045285

To turn on the rear fog lamp:

Position the light switch in the headlamp position, and then turn the light switch (1) to the rear fog lamp position.

To turn the rear fog lamps off, do one of the following:

- Turn off the headlamp switch.
- Turn the light switch to the rear fog lamp position again.

### **Battery saver function**

The purpose of this feature is to prevent the battery from being discharged. The system automatically turns off the position lamp when the driver turns the engine off and opens the driver-side door.

With this feature, the position lamps will turn off automatically if the driver parks on the side of road at night.

If necessary, to keep the lamps on when the engine is turned off, perform the following:

- 1) Open the driver-side door.
- 2) Turn the position lamps OFF and ON again using the light switch on the steering column.

### **Headlamp delay function**

If you place the ignition switch to the ACC or OFF position with the headlamps ON, the headlamps (and/or position lamps) remain on for about 5 minutes. However, with the engine off if the driver's door is opened and closed, the headlamps (and/or position lamps) are turned off after 15 seconds.

The headlamps (and/or position lamps) can be turned off by pressing the lock button on the remote key or smart key twice or turning the light switch to the OFF or AUTO position. However, if you turn the light switch to the AUTO position when it is dark outside, the headlamps will not be turned off.

You can activate or deactivate the Headlamp Delay function from the User Settings mode on the LCD display. **For more details, refer to "LCD Display" in this chapter.**

### **NOTICE**

**If the driver gets out of the vehicle through other doors (except driver's door), the battery saver function does not operate and the headlamp delay function does not turn off automatically. Therefore, it causes the battery to be discharged. In this case, make sure to turn off the lamp before getting out of the vehicle.**

### **Daytime running light (DRL) (if equipped)**

The Daytime Running Lights (DRL) can make it easier for others to see the front of your vehicle during the day, especially after dawn and before sunset.

The DRL system will turn the dedicated lamp OFF when:

1. The headlamps or front fog lights are in the ON position.
2. The position light switch is in the ON position.
3. The engine is turned off.

### **Headlamp leveling device**

It automatically adjusts the headlamp beam level according to the number of passengers and loading weight in the luggage area.

It also adjusts to the appropriate headlamp beam level for various situations.

#### **WARNING**

**If the function does not work properly, we recommend that the system be inspected by an authorized HYUNDAI dealer. Do not attempt to inspect or replace the wiring yourself.**

### **Static bending light (if equipped)**

While driving a corner, for greater visibility and safety, either the left or right side static bending light will turn on automatically. The static bending light will turn on when one of the following conditions occur.

- Vehicle speed is less than 10 km/h (6 mph) and steering wheel angle is turned approximately 80 degrees with the low beam on.
- Vehicle speed is between 10 km/h (6 mph) to 90 km/h (56 mph) and steering wheel angle is turned approximately 35 degrees with the low beam on.
- When the vehicle is in reverse with one of the conditions above satisfied, the light opposite to the direction the steering wheel is steered will turn on.

## Welcome system (if equipped)

### Welcome light (if equipped)



OPDEN047051

### Puddle lamp (if equipped)

When all the doors (and tailgate) are closed and locked, the puddle lamp will come on for about 15 seconds if any of the below is performed.

- When the door unlock button is pressed on the remote key or smart key.
- When the button of the outside door handle is pressed with the smart key in possession.

### Door handle lamp (if equipped)

When all the doors (and tailgate) are closed and locked, the door handle lamp will come on for about 15 seconds if any of the below is performed.

- When the door unlock button is pressed on the remote key or smart key.
- When the button of the outside door handle is pressed with the smart key in possession.

### Headlamp and position lamp

When the headlamp (lamp switch in the headlamp or AUTO position) is on and all doors (and tailgate) are locked and closed, the position lamp and headlamp will come on for 15 seconds when the door unlock button is pressed on the remote key or smart key.

At this time, if you press the door lock or unlock button, the position lamp and headlamp will turn off immediately.

You can activate or deactivate the Welcome Light from the User Settings mode on the LCD display.

**For more details, refer to "LCD Display" in this chapter.**

### Interior lamp

When the interior lamp switch is in the DOOR position and all doors (and tailgate) are closed and locked, the room lamp will come on for 30 seconds if any of the below is performed.

- When the door unlock button is pressed on the remote key or smart key.
- When the button of the outside door handle is pressed with the smart key in possession.

At this time, if you press the door lock or unlock button, the room lamp will turn off immediately.



### Interior lights

#### NOTICE

Do not use the interior lights for extended periods when the engine is turned off otherwise the battery will discharge.

#### WARNING

Do not use the interior lights when driving in the dark. The interior lights may obscure your view and cause an accident.

#### Interior lamp AUTO cut

The interior lamps will automatically go off approximately 20 minutes after the engine is turned off and the doors are closed. If a door is opened, the lamp will go off 40 minutes after the engine is turned off. If the doors are locked and the vehicle enters the armed stage of the theft alarm system, the lamps will go off five seconds later.

### Front lamps





- (1) Front Map Lamp
- (2) Front Room Lamp
- (3) Front Door Lamp

#### Front map lamp

Press the map lamp lens (1) to turn ON the map lamp. Re-press the map lamp lens to turn OFF the map lamp.

### Front room lamp

-  :  
Press the button to turn ON the room lamp for the front/rear seats.
-  :  
Press the button to turn OFF the room lamp for the front/rear seats.

### Front door lamp ( )

The room lamp for the front/rear seats is automatically turned ON for approximately 30 seconds, when a door is opened.

The room lamp for the front/rear seats is automatically turned ON for approximately 15 seconds, when the remote key (smart key) unlocks the doors. The room lamp fades out, when the ignition switch is placed to the ON position in 15 seconds. The room lamp remains ON up to 20 minutes, when a door is opened with the ignition switch in the either the ACC or OFF position.

## Rear lamps

■ Type A

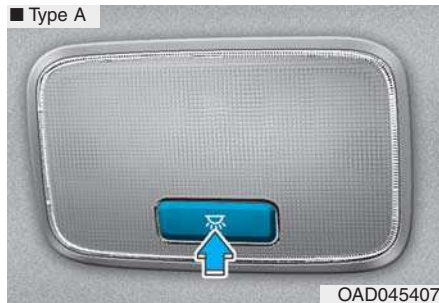

■ Type B

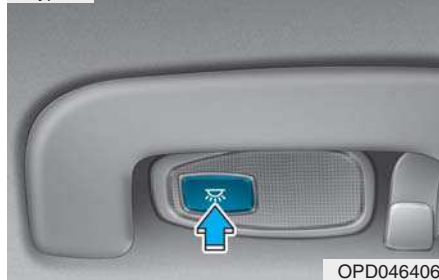

### Rear room lamp switch :

Press this button to turn the room lamp on and off.

### NOTICE

Do not leave the lamp switches on for an extended period of time when the engine is turned off.

## Luggage compartment lamp

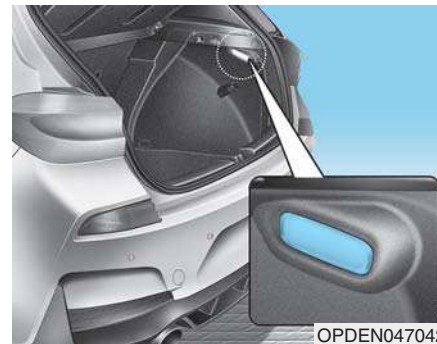

The luggage compartment lamp comes on when the tailgate is opened.



### NOTICE

The luggage compartment lamp comes on as long as the tailgate is open. To prevent unnecessary charging system drain, close the tailgate securely after using the tailgate.

### Vanity mirror lamp (if equipped)



Push the switch to turn the light on or off.

-  : The lamp will turn on if this button is pressed.
-  : The lamp will turn off if this button is pressed.

#### **NOTICE**

**Always have the switch in the off position when the vanity mirror lamp is not in use. If the sunvisor is closed without the lamp off, it may discharge the battery or damage the sunvisor.**

### Puddle lamp (if equipped)

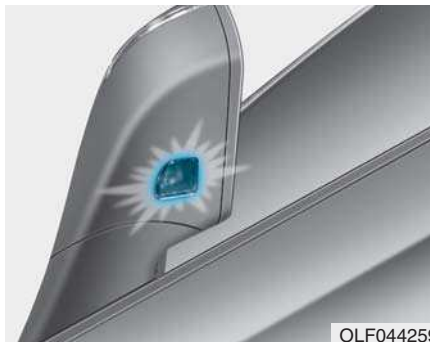

#### **Welcome light**

When all doors (and tailgate) are closed and locked, the puddle lamp will come on for 15 seconds if the door is unlocked by the smart key or outside door handle button.

**For more details, refer to "Welcome System" in this chapter.**

### Escort light

When the ignition switch is in the OFF position and the driver's door is opened, the puddle lamp will come on for 30 seconds. If the driver's door is closed within the 30 seconds, the puddle lamp will turn off after 15 seconds. If the driver's door is closed and locked, the puddle lamp will turn off immediately.

The Puddle Lamp Escort Light will turn on only the first time the driver's door is opened after the engine is turned off.

## WIPERS AND WASHERS

### ■ Front windshield wiper/washer

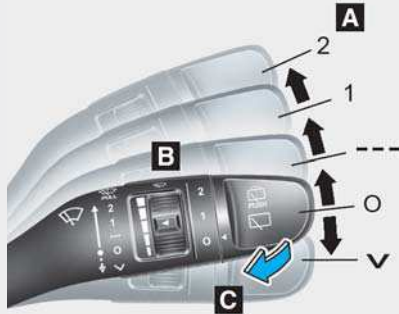

#### A : Wiper speed control (front)

- √ – Single wipe
- O – Off
- --- – Intermittent wipe
- AUTO\* – Auto control wipe
- 1 – Low wiper speed
- 2 – High wiper speed

#### B : Intermittent control wipe time adjustment

#### C : Wash with brief wipes (front) (pull lever towards you)

#### D : Rear wiper control\*

- 2 – High wiper speed
- 1 – Low wiper speed
- O – Off

#### E : Wash with brief wipes (rear) (push lever away from you)

\* : if equipped

### ■ Rear windshield wiper/washer

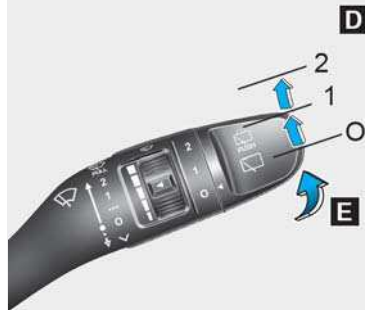

OPDE046058/OPDE046060

## Windshield wipers

Operates as follows when the ignition switch is turned ON.

∇ : For a single wiping cycle, move the lever down and release it. The wipers will operate continuously if the lever is held in this position.

O : Wiper is not in operation

--- : Wiper operates intermittently at the same wiping intervals. Use this mode in light rain or mist. To vary the speed setting, turn the speed control knob.

1 : Normal wiper speed

2 : Fast wiper speed

### **i** Information

If there is heavy accumulation of snow or ice on the windshield, defrost the windshield for about 10 minutes, or until the snow and/or ice is removed before using the windshield wipers to ensure proper operation.

If you do not remove the snow and/or ice before using the wiper and washer, it may damage the wiper and washer system.

### **AUTO (Automatic) control (if equipped)**



The rain sensor located on the upper end of the windshield glass senses the amount of rainfall and controls the wiping cycle for the proper interval. The more it rains, the faster the wiper operates.

When the rain stops, the wiper stops. To vary the speed setting, turn the speed control knob (1).

If the wiper switch is set in AUTO mode when the ignition switch is in the ON position, the wiper will operate once to perform a self-check of the system. Set the wiper to OFF position when the wiper is not in use.

### **⚠ WARNING**

To avoid personal injury from the windshield wipers, when the engine is running and the windshield wiper switch is placed in the AUTO mode:

- Do not touch the upper end of the windshield glass facing the rain sensor.
- Do not wipe the upper end of the windshield glass with a damp or wet cloth.
- Do not put pressure on the windshield glass.

### **NOTICE**

- When washing the vehicle, set the wiper switch in the O position to stop the auto wiper operation. The wiper may operate and be damaged if the switch is set in the AUTO mode while washing the vehicle.
- Do not remove the sensor cover located on the upper end of the passenger side windshield glass. Damage to system parts could occur and may not be covered by your vehicle warranty.

## Windshield washers



OPDE046062

In the O position, pull the lever gently toward you to spray washer fluid on the windshield and to run the wipers 1-3 cycles. The spray and wiper operation will continue until you release the lever.

If the washer does not work, you may need to add washer fluid to the washer fluid reservoir.

### WARNING

When the outside temperature is below freezing, **ALWAYS** warm the windshield using the defroster to prevent the washer fluid from freezing on the windshield and obscuring your vision which could result in an accident and serious injury or death.

### NOTICE

- **To prevent possible damage to the washer pump, do not operate the washer when the fluid reservoir is empty.**
- **To prevent possible damage to the wipers or windshield, do not operate the wipers when the windshield is dry.**
- **To prevent damage to the wiper arms and other components, do not attempt to move the wipers manually.**
- **To prevent possible damage to the wipers and washer system, use anti-freezing washer fluids in the winter season or cold weather.**

## Front windshield wiper service position



OPDE076027

This vehicle has a "hidden" wiper design which means that the wipers cannot be lifted when they are in their bottom resting position.

1. Within 20 seconds of turning off the engine, move the wiper lever down and hold it to the √ position for about 2 seconds until the wipers move to the top wipe position.
2. At this time you can lift the wipers off the windshield.
3. Gently put the wipers back down onto the windshield.
4. Turn the wipers to any ON position to return the wipers to the bottom resting position.

### Rear window wiper and washer switch (if equipped)

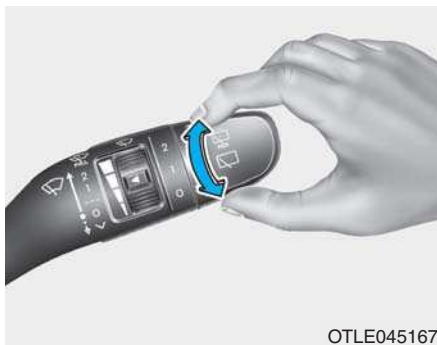

The rear window wiper and washer switch is located at the end of the wiper and washer switch lever.

Turn the switch to the desired position to operate the rear wiper and washer.

- 2 – High wiper speed
- 1 – Low wiper speed
- O – Off

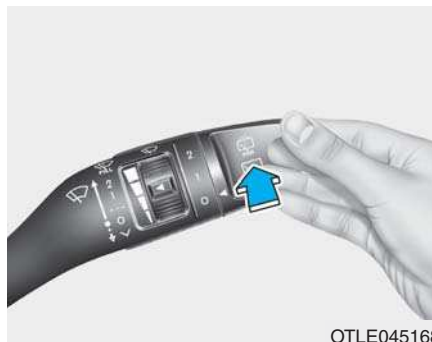

Push the lever away from you to spray rear washer fluid and to run the rear wipers 1~3 cycles. The spray and wiper operation will continue until you release the lever. (if equipped)

### ***Auto rear wiper (if equipped)***

The rear wiper will operate while the vehicle is in reverse with the front wiper ON by selecting the function on the LCD display.

Go to 'User Settings → Convenience → Auto Rear Wiper (reverse)'.

## DRIVER ASSIST SYSTEM

### Rear view camera (if equipped)

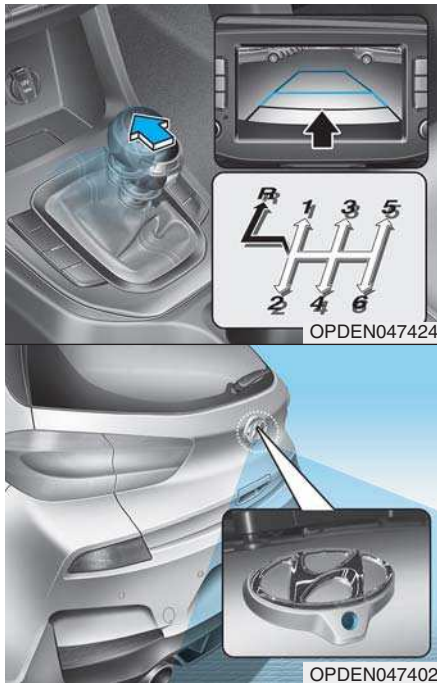

The Rear View Camera will activate when the engine is running and the shift lever is in the R (Reverse) position.

This is a supplemental system that shows behind the vehicle through the mirror or navigation display while backing-up.

### **⚠ WARNING**

The rear camera display is not a safety device. It only serves to assist the driver in identifying objects directly behind the middle of the vehicle. The camera does NOT cover the complete area behind the vehicle.

### **⚠ WARNING**

- Never rely solely on the rear camera display when backing-up.
- ALWAYS look around your vehicle to make sure there are no objects or obstacles before moving the vehicle in any direction to prevent a collision.
- Always pay close attention when the vehicle is driven close to objects, particularly pedestrians, and especially children.



### NOTICE

- Do not spray the camera or its surrounding area directly with a high pressure washer. Shock applied from high pressure water may cause the device to not operate normally.
- Do not use any cleanser containing acid or alkaline detergents when cleaning the lens. Use only a mild soap or neutral detergent, and rinse thoroughly with water.

### **i** Information

Always keep the camera lens clean. The camera may not work normally if the lens is covered with dirt, water or snow.

### Rear parking assist system (if equipped)

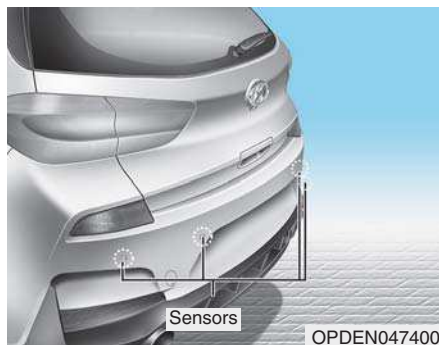

The Rear Parking Assist System assists the driver during reverse movement of the vehicle by chiming if any object is sensed within the distance of 120 cm (50 inches) behind the vehicle.

This system is a supplemental system that senses objects within the range and location of the sensors, it cannot detect objects in other areas where sensors are not installed.

### **⚠** WARNING



- ALWAYS look around your vehicle to make sure there are not any objects or obstacles before moving the vehicle in any direction to prevent a collision.
- Always pay close attention when the vehicle is driven close to objects, particularly pedestrians, and especially children.
- Be aware that some objects may not be visible on the screen or be detected by the sensors, due to the objects distance, size or material, all of which can limit the effectiveness of the sensor.

## Operation of the Rear Parking Assist System

### Operating condition

- This system will activate when backing up with the ignition switch in the ON position. However, if vehicle speed exceeds 5 km/h (3 mph), the system may not detect objects.
- If vehicle speed exceeds 10 km/h (6 mph), the system will not warn you even though objects are detected.
- When more than two objects are sensed at the same time, the closest one will be recognized first.

### Types of warning sound and indicator

Types of warning sound	Indicator
When an object is 120 cm to 60 cm (47 in. to 24 in.) from the rear bumper : Buzzer beeps intermittently.	
When an object is 60 cm to 30 cm (24 in. to 12 in.) from the rear bumper : Buzzer beeps more frequently.	
When an object is within 30 cm (12 in.) of the rear bumper : Buzzer beeps continuously.	

### NOTICE

- The indicator may differ from the illustration depending on objects or sensors status. If the indicator blinks, we recommend that you have your vehicle checked by an authorized HYUNDAI dealer.
- If the audible warning does not sound or if the buzzer sounds intermittently when shifting into R (Reverse) position, this may indicate a malfunction with the Parking Assist System. If this occurs, we recommend that you have your vehicle checked by an authorized HYUNDAI dealer as soon as possible.

### To turn off the Rear Parking Assist System (if equipped)



Push the button to turn off the Rear Parking Assist System. The indicator light on the button will turn on.

### Non-operational conditions of Parking Assist System

The Rear Parking Assist System may not operate normally when:

- Moisture is frozen to the sensor.
- Sensor is covered with foreign matter, such as snow or water, or the sensor cover is blocked.

There is a possibility of the Rear Parking Assist System malfunction when:

- Driving on uneven road surfaces such as unpaved roads, gravel, bumps, or gradient.
- Objects generating excessive noise such as vehicle horns, loud motorcycle engines, or truck air brakes can interfere with the sensor.
- Heavy rain or water spray is present.
- Wireless transmitters or mobile phones are present near the sensor.
- The sensor is covered with snow.
- Any non-factory equipment or accessories have been installed, or if the vehicle bumper height or sensor installation has been modified.

Detecting range may decrease when:

- Outside air temperature is extremely hot or cold.
- Undetectable objects smaller than 1 m (40 inches) and narrower than 14 cm (6 inches) in diameter.

The following objects may not be recognized by the sensor:

- Sharp or slim objects such as ropes, chains or small poles.
- Objects, which tend to absorb sensor frequency such as clothes, spongy material or snow.

 **WARNING**

**Your new vehicle warranty does not cover any accidents or damage to the vehicle or injuries to its occupants related to a Rear Parking Assist System. Always drive safely and cautiously.**

***Rear parking assist system precautions***

- The rear parking assist system may not sound consistently depending on the speed and shapes of the objects detected.
  - The rear parking assist system may malfunction if the vehicle bumper height or sensor installation has been modified or damaged. Any non-factory installed equipment or accessories may also interfere with the sensor performance.
  - The sensor may not recognize objects less than 30 cm (11 in.) from the sensor, or it may sense an incorrect distance. Use caution.
  - When the sensor is frozen or stained with snow, dirt, or water, the sensor may be inoperative until the stains are removed using a soft cloth.
  - Do not push, scratch or strike the sensor with any hard objects that could damage the surface of the sensor. Sensor damage could occur.
- Do not spray the sensors or its surrounding area directly with a high pressure washer. Shock applied from high pressure water may cause the device to not operate normally.

### Parking assist system (if equipped)

#### ■ Front sensor

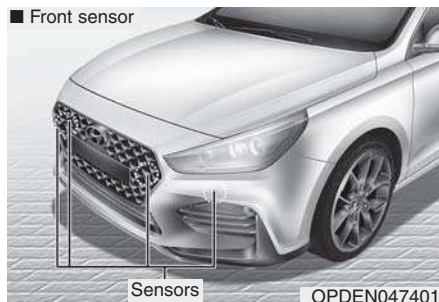

#### ■ Rear sensor

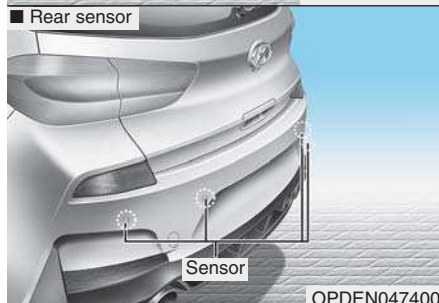

The Parking Assist System assists the driver during movement of the vehicle by chiming if any object is sensed within the distance of 100 cm (39 inches) in front and 120 cm (47 inches) behind the vehicle.

This system is a supplemental system that senses objects within the range and location of the sensors, it cannot detect objects in other areas where sensors are not installed.

#### **⚠ WARNING**

- **ALWAYS** look around your vehicle to make sure there are no objects or obstacles before moving the vehicle in any direction to prevent a collision.
- Always pay close attention when the vehicle is driven close to objects, particularly pedestrians, and especially children.
- Be aware that some objects may not be visible on the screen or be detected by the sensors, due to the objects distance, size or material, all of which can limit the effectiveness of the sensor.

### Operation of the Parking Assist System









#### Operating condition

- This system will activate when the Parking Assist System button is pressed with the engine running.

- The Parking Assist System button turns on automatically and activates the Parking Assist System when you move the shift lever to the R (Reverse) position. However, if vehicle speed exceeds 10 km/h (6 mph), the system will not warn you even though objects are detected, and if vehicle speed exceeds 20 km/h (12 mph), the system will turn off automatically. To turn on the system, press the Parking Assist System button.
- When more than two objects are sensed at the same time, the closest one will be recognized first.

### Types of warning sound and indicator

cm (in)

Distance from object		Warning indicator		Warning sound
		When driving forward	When driving rearward	
61 ~ 100 (24 ~39)	Front		-	Buzzer beeps intermittently
61 ~ 120 (24 ~47)	Rear	-		Buzzer beeps intermittently
31 ~ 60 (12 ~24)	Front			Buzzer beeps frequently
	Rear	-		Buzzer beeps frequently
30 (12)	Front			Buzzer sounds continuously
	Rear	-		Buzzer sounds continuously

#### NOTICE

- The indicator may differ from the illustration depending on objects or sensors status. If the indicator blinks, we recommend that the system be checked by an authorized HYUNDAI dealer.
- If the audible warning does not sound or if the buzzer sounds intermittently when shifting into R (Reverse) position, this may indicate a malfunction with the Parking Assist System. If this occurs, we recommend that you have your vehicle checked by an authorized HYUNDAI dealer as soon as possible.

### ***Non-operational conditions of Parking Assist System***

**Parking Assist System may not operate normally when:**

- Moisture is frozen to the sensor.
- Sensor is covered with foreign matter, such as snow or water, or the sensor cover is blocked.

**There is a possibility of Parking Assist System malfunction when:**

- Driving on uneven road surfaces such as unpaved roads, gravel, bumps, or gradient.
- Objects generating excessive noise such as vehicle horns, loud motorcycle engines, or truck air brakes can interfere with the sensor.
- Heavy rain or water spray is present.
- Wireless transmitters or mobile phones are present near the sensor.
- The sensor is covered with snow.
- Any non-factory equipment or accessories have been installed, or if the vehicle bumper height or sensor installation has been modified.

**Detecting range may decrease when:**

- Outside air temperature is extremely hot or cold.
- Undetectable objects smaller than 1 m and narrower than 14 cm in diameter.

**The following objects may not be recognized by the sensor:**

- Sharp or slim objects such as ropes, chains or small poles.
- Objects, which tend to absorb sensor frequency such as clothes, spongy material or snow.

### **⚠ WARNING**

**Your new vehicle warranty does not cover any accidents or damage to the vehicle or injuries to its occupants related to a Parking Assist System. Always drive safely and cautiously.**

### ***Parking assist system precautions***

- The parking assist system may not sound consistently depending on the speed and shapes of the objects detected.
- The parking assist system may malfunction if the vehicle bumper height or sensor installation has been modified or damaged. Any non-factory installed equipment or accessories may also interfere with the sensor performance.
- The sensor may not recognize objects less than 30 cm (11 in.) from the sensor, or it may sense an incorrect distance. Use caution.
- When the sensor is frozen or stained with snow, dirt, or water, the sensor may be inoperative until the stains are removed using a soft cloth.
- Do not push, scratch or strike the sensor. Sensor damage could occur.
- Do not spray the sensors or its surrounding area directly with a high pressure washer. Shock applied from high pressure water may cause the device to not operate normally.

## AUTOMATIC CLIMATE CONTROL SYSTEM (IF EQUIPPED)



1. Driver's temperature control knob
2. Passenger's temperature control knob
3. AUTO (automatic control) button
4. OFF button
5. Fan speed control button
6. Mode selection button
7. SYNC button
8. Front windshield defroster button
9. Rear window defroster button
10. Air conditioning button
11. Air intake control button
12. Climate control information screen



### Automatic heating and air conditioning

The Automatic Climate Control System is controlled by setting the desired temperature.



1. Press the AUTO button.

The modes, fan speeds, air intake and air-conditioning will be controlled automatically by the temperature setting you select.

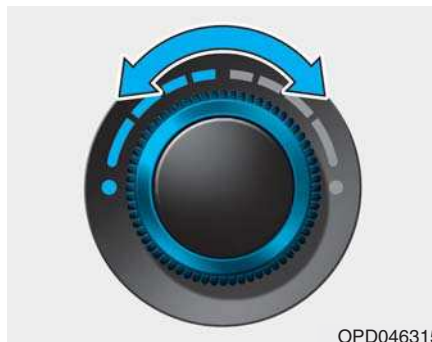

2. Turn the temperature control knob to the desired temperature. If the temperature is set to the lowest setting (Lo), the air conditioning system will operate continuously. After the interior has cooled sufficiently, adjust the knob to a higher temperature set point whenever possible.

To turn the automatic operation off, select any button of the following:

- Mode selection button
- Front windshield defroster button (Press the button one more time to deselect the front windshield defroster function. The 'AUTO' sign will illuminate on the information display once again.)
- Fan speed control button

The selected function will be controlled manually while other functions operate automatically.

For your convenience and to improve the effectiveness of the climate control, use the AUTO button and set the temperature to 23°C (73°F).



### **i** Information

Never place anything near the sensor to ensure better control of the heating and cooling system.

## Manual heating and air conditioning

The heating and cooling system can be controlled manually by pushing buttons other than the AUTO button. In this case, the system works sequentially according to the order of buttons selected. When pressing any button except the AUTO button while using automatic operation, the functions not selected will be controlled automatically.

1. Start the engine.
2. Set the mode to the desired position.  
For improving the effectiveness of heating and cooling, select:
  - Heating:
  - Cooling:
3. Set the temperature control to the desired position.

4. Set the air intake control to the outside (fresh) air position.
5. Set the fan speed control to the desired speed.
6. If air conditioning is desired, turn the air conditioning system on.
7. Press the AUTO button to convert to full automatic control of the system.

### Mode selection

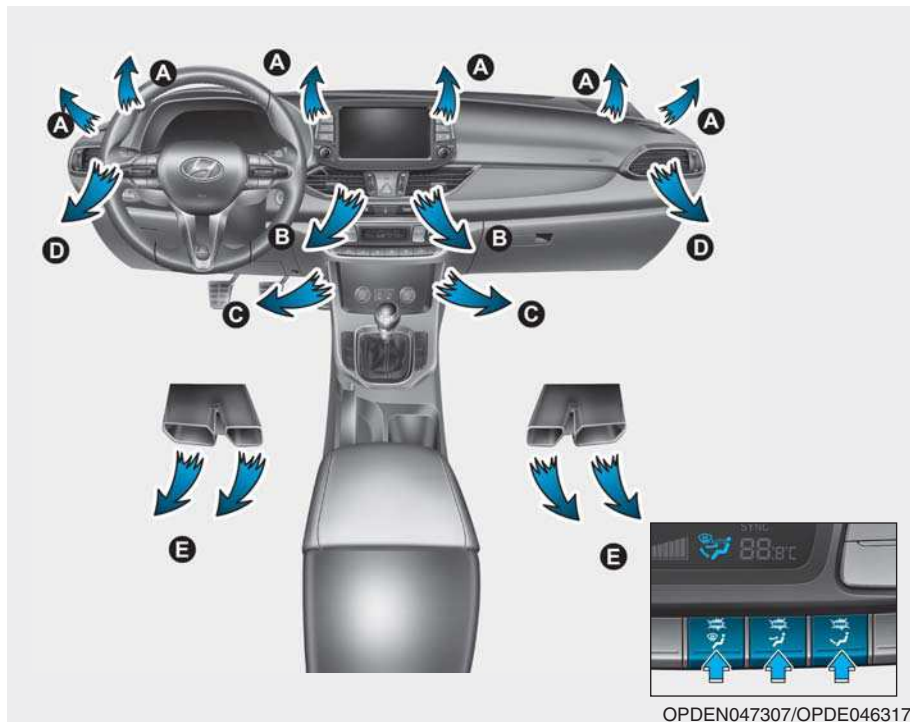

The mode selection button controls the direction of the air flow through the ventilation system.

 **Defrost-Level (A, D)**

Most of the air flow is directed to the windshield.

 **Face-Level (B, D)**

Air flow is directed toward the upper body and face. Additionally, each outlet can be controlled to direct the air discharged from the outlet.

 **Floor-Level (A, C, D, E)**

Most of the air flow is directed to the floor.

Also you may select 2~3 modes at the same time.

- face ( ) + floor ( ) mode
- face ( ) + defrost ( ) mode
- floor ( ) + defrost ( ) mode
- face ( ) + floor ( ) + defrost ( ) mode



### Defrost-Level (A)

Most of the air flow is directed to the windshield with a small amount of air directed to the side window defrosters.

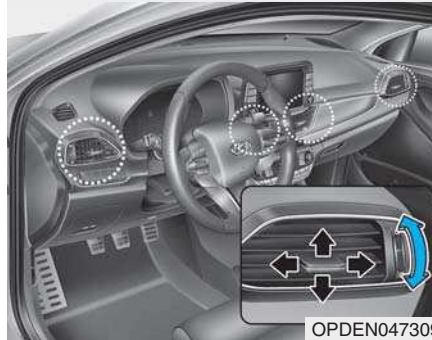

### Instrument panel vents

The outlet vents can be opened (☼) or closed (○) separately using the thumbwheel.

Also, you can adjust the direction of air delivery from these vents using the vent control lever as shown.

### Temperature control

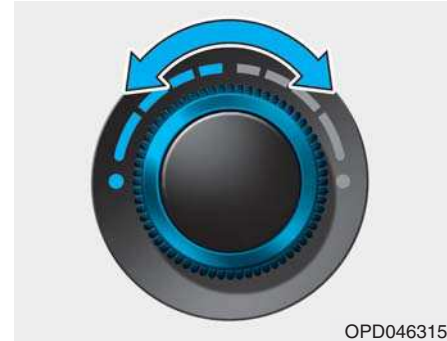

The temperature will increase by turning the knob to the right. The temperature will decrease by turning the knob to the left.



### Adjusting the driver and passenger side temperature equally

- Press the “SYNC” button to adjust the driver and passenger side temperature equally.

The passenger side temperature will be set to the same temperature as the driver side temperature.

- Turn the driver side temperature control knob. The driver and passenger side temperature will be adjusted equally.

### Adjusting the driver and passenger side temperature individually

Press the “SYNC” button again to adjust the driver and passenger side temperature individually. The button indicator will turn off.

### Temperature conversion

If the battery has been discharged or disconnected, the temperature mode display will reset to Centigrade.

To change the temperature unit from °C to °F or °F to °C :

- Automatic climate control system  
Press the AUTO button for 3 seconds while pressing the OFF button.
- Instrument cluster  
Go to User Settings Mode → Other Features → Temperature Unit.

The temperature unit on both the cluster LCD display and the climate control screen will change.

### Air intake control



This is used to select the outside (fresh) air position or recirculated air position.

To change the air intake control position, push the control button.

### Recirculated air position



With the recirculated air position selected, air from the passenger compartment will be drawn through the heating system and heated or cooled according to the function selected.

### Outside (fresh) air position



With the outside (fresh) air position selected, air enters the vehicle from outside and is heated or cooled according to the function selected.

### **i** Information

Using the system in the fresh air position is recommended.

Prolonged operation of the heater in the recirculated air position (without air conditioning selected) can cause fogging of the windshield and side windows and the air within the passenger compartment will become stale.

(continued)

(continued)

In addition, prolonged use of the air conditioning with the recirculated air position selected will result in excessively dry air in the passenger compartment.

### **⚠** WARNING

- Continued climate control system operation in the recirculated air position may allow humidity to increase inside the vehicle which may fog the glass and obscure visibility.
- Do not sleep in a vehicle with the air conditioning or heating system on. It may cause serious harm or death due to a drop in the oxygen level and/or body temperature.
- Continued climate control system operation in the recirculated air position can cause drowsiness or sleepiness, and loss of vehicle control. Set the air intake control to the outside (fresh) air position as much as possible while driving.

### Fan speed control



OPDE046323

The fan speed can be set as desired by pushing the fan speed control button.

More air is delivered with higher fan speeds.

Pressing the OFF button turns off the fan.

### **NOTICE**

Operating the fan when the ignition switch is in the ON position could cause the battery to discharge. Operate the fan when the engine is running.

### Air conditioning



OPDE046322

Push the A/C button to turn the air conditioning system on (indicator light will illuminate).

Push the button again to turn the air conditioning system off.

### OFF mode



OPDE046324



Push the OFF button to turn the climate control system off. However, you can still operate the mode and air intake buttons as long as the ignition switch is in the ON position.

### System operation

#### Ventilation

1. Set the mode to the  position.
2. Set the air intake control to the outside (fresh) air position.
3. Set the temperature control to the desired position.
4. Set the fan speed control to the desired speed.

#### Heating

1. Set the mode to the  position.
2. Set the air intake control to the outside (fresh) air position.
3. Set the temperature control to the desired position.
4. Set the fan speed control to the desired speed.
5. If dehumidified heating is desired, turn the air conditioning system on.
  - If the windshield fogs up, set the mode to the  or  position.

## Operation Tips

- To keep dust or unpleasant fumes from entering the vehicle through the ventilation system, temporarily set the air intake control to the recirculated air position. Be sure to return the control to the fresh air position when the irritation has passed to keep fresh air in the vehicle. This will help keep the driver alert and comfortable.
- To prevent interior fog on the windshield, set the air intake control to the fresh air position and fan speed to the desired position, turn on the air conditioning system, and adjust the temperature control to the desired temperature.

## Air conditioning

HYUNDAI Air Conditioning Systems are filled with R-134a or R-1234yf refrigerant.

1. Start the engine. Push the air conditioning button.
2. Set the mode to the  position.
3. Set the air intake control to the outside air or recirculated air position.
4. Adjust the fan speed control and temperature control to maintain maximum comfort.

### Information

**Your vehicle is filled with R-134a or R-1234yf according to the regulation in your country at the time of production. You can find out which air conditioning refrigerant is applied to your vehicle on the label located inside of the hood. Refer to chapter 8 for the location of the air conditioning refrigerant label.**

### NOTICE

- **The refrigerant system should only be serviced by trained and certified technicians to insure proper and safe operation.**
- **The refrigerant system should be serviced in a well-ventilated place.**
- **The air conditioning evaporator (cooling coil) shall never be repaired or replaced with one removed from a used or salvaged vehicle and new replacement MAC evaporators shall be certified (and labeled) as meeting SAE Standard J2842.**



### **NOTICE**

- **When using the air conditioning system, monitor the temperature gauge closely while driving up hills or in heavy traffic when outside temperatures are high. Air conditioning system operation may cause engine overheating. Continue to use the fan but turn the air conditioning system off if the temperature gauge indicates engine overheating.**
- **When opening the windows in humid weather air conditioning may create water droplets inside the vehicle. Since excessive water droplets may cause damage to electrical equipment, air conditioning should only be used with the windows closed.**

### **Air conditioning system operation tips**

- If the vehicle has been parked in direct sunlight during hot weather, open the windows for a short time to let the hot air inside the vehicle escape.
- After sufficient cooling has been achieved, switch back from the recirculated air to the fresh outside air position.
- To help reduce moisture inside of the windows on rainy or humid days, decrease the humidity inside the vehicle by operating the air conditioning system with the windows and sunroof closed.
- Use the air conditioning system every month for a few minutes to ensure maximum system performance.
- If you operate the air conditioner excessively, the difference between the temperature of the outside air and that of the windshield could cause the outer surface of the windshield to fog up, causing loss of visibility. In this case, set the mode selection button to the  position and set the fan speed control button to the lowest speed setting.

## System maintenance

### Climate control air filter

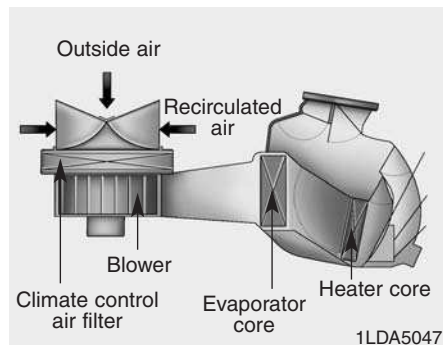

This filter is installed behind the glove box. It filters the dust or other pollutants that enter the vehicle through the heating and air conditioning system.

We recommend that the climate control air filter be replaced by an authorized HYUNDAI dealer according to the maintenance schedule. If the vehicle is being driven in severe conditions such as dusty or rough roads, more frequent climate control filter inspections and changes are required.

If the air flow rate suddenly decreases, we recommend the system be checked at an authorized HYUNDAI dealer.

### Checking the amount of air conditioner refrigerant and compressor lubricant

When the amount of refrigerant is low, the performance of the air conditioning is reduced. Overfilling also reduces the performance of the air conditioning system.

Therefore, if abnormal operation is found, we recommend that the system be inspected by an authorized HYUNDAI dealer.

#### ⚠ WARNING

##### Vehicles equipped with R-134a



**Because the refrigerant is at very high pressure, the air conditioning system should only be serviced by trained and certified technicians. It is important that the correct type and amount of oil and refrigerant is used. Otherwise, it may cause damage to the vehicle and personal injury.**

#### ⚠ WARNING

##### Vehicles equipped with R-1234yf



**Because the refrigerant is mildly flammable at very high pressure, the air conditioning system should only be serviced by trained and certified technicians. It is important that the correct type and amount of oil and refrigerant is used. Otherwise, it may cause damage to the vehicle and personal injury.**

We recommend the air conditioning system be serviced by an authorized HYUNDAI dealer.

### Air Conditioning refrigerant label

■ Example

• Type A

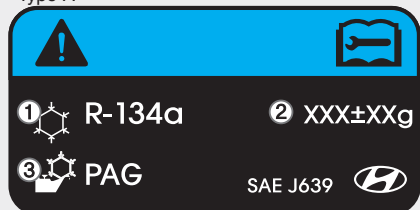

ODH044365R

• Type B



ODH043366

Each symbols and specification on air conditioning refrigerant label means as below:

1. Classification of refrigerant
2. Amount of refrigerant
3. Classification of Compressor lubricant

You can find out which air conditioning refrigerant is applied to your vehicle on the label located inside of the hood.



Refer to chapter 8 for the location of the air conditioning refrigerant label.

The actual Air Conditioning refrigerant label in the vehicle may differ from the illustration.

## WINDSHIELD DEFROSTING AND DEFOGGING

### ⚠ WARNING

#### Windshield heating

Do not use the  or  position during cooling operation in extremely humid weather. The difference between the temperature of the outside air and that of the windshield could cause the outer surface of the windshield to fog up, causing loss of visibility. In this case, set the mode selection knob or button to the  position and fan speed control button to lower speed.

- For maximum windshield defrosting, set the temperature control knob to the highest temperature setting and the fan control button to the highest fan speed. Select the front defrost button on the climate control display. After the engine warm-up period, warm air will be directed to the front windshield.
- If warm air to the floor is desired while defrosting or defogging, set the mode to the floor-defrost position.
- Before driving, clear all snow and ice from the windshield, rear window, outside rear view mirrors, and all side windows.
- Clear all snow and ice from the hood and air inlet in the cowl grill to improve heater and defroster efficiency and to reduce the probability of fogging up inside of the windshield.

### **i** Information

If the engine temperature is still cold after starting, then a brief engine warm up period may be required for the vented air flow to become warm or hot.

## Automatic climate control system

### To defog inside windshield

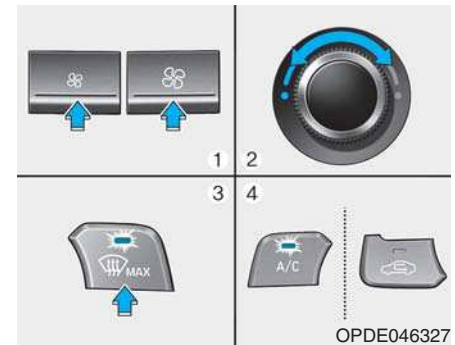



1. Select the desired fan speed.
2. Select the desired temperature.
3. Press the defroster button ().
4. The air-conditioning will turn on according to the detected ambient temperature, outside (fresh) air position and higher fan speed will be selected automatically.

If the air-conditioning, outside (fresh) air position and higher fan speed are not selected automatically, adjust the corresponding button or knob manually.

If the  position is selected, lower fan speed is controlled to higher fan speed.

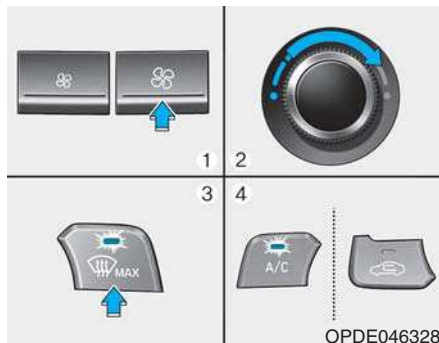
### To defrost outside windshield



1. Set fan speed to the highest position.
2. Set temperature to the extreme hot (HI) position.
3. Press the defroster button (.
4. The air-conditioning will turn on according to the detected ambient temperature and outside (fresh) air position will be selected automatically.

If the  position is selected, lower fan speed is controlled to higher fan speed.

### Defroster

#### NOTICE

To prevent damage to the conductors bonded to the inside surface of the rear window, never use sharp instruments or window cleaners containing abrasives to clean the window.

#### Information

If you want to defrost and defog the front windshield, refer to “Windshield Defrosting and Defogging” in this chapter.

## Rear window defroster



OPDE046319

The defroster heats the window to remove frost, fog and thin ice from the interior and exterior of the rear window, while the engine is running.

- To activate the rear window defroster, press the rear window defroster button located in the center facia switch panel. The indicator on the rear window defroster button illuminates when the defroster is ON.
- To turn off the defroster, press the rear window defroster button again.

### **i** Information

- If there is heavy accumulation of snow on the rear window, brush it off before operating the rear defroster.
- The rear window defroster automatically turns off after approximately 20 minutes or when the ignition switch is in the OFF position.

### Outside mirror defroster (if equipped)

If your vehicle is equipped with outside mirror defrosters, they will operate at the same time you turn on the rear window defroster.

### Front wiper deicer (if equipped)

If your vehicle is equipped with the wiper deicer, it will operate at the same time you turn on the rear window defroster.

## Auto defogging system (if equipped)

Auto defogging reduces the possibility of fogging up the inside of the windshield by automatically sensing the moisture on inside the windshield.

The auto defogging system operates when the heater or air conditioning is on.

### **i** Information

**The auto defogging system may not operate normally, when the outside temperature is below -10 °C.**

To cancel or set the Auto Defogging System, keep the front defroster button pressed for 3 seconds. The “ADS OFF” symbol will be shown in the climate display to inform you that the system is deactivated. To re-activate the auto defogging system, follow the procedure mentioned above and the “ADS OFF” symbol will disappear.

If the battery has been disconnected or discharged, it resets to the auto defogging status.

### **i** Information

For efficiency, do not select recirculated air position while the Auto defogging system is operating.

### **NOTICE**

**Do not remove the sensor cover located on the upper end of the windshield glass.**

**Damage to system parts could occur and may not be covered by your vehicle warranty.**

## CLIMATE CONTROL ADDITIONAL FEATURES

### Cluster ionizer (if equipped)

When the ignition switch is in the ON position, the clean air function turns on automatically.

Also, the clean air function turns off automatically, when the ignition switch is in the OFF position.

### Automatic ventilation (if equipped)

To increase cabin air quality and reduce windscreen misting, air recirculation mode switches off automatically after about 5 to 30 minutes, depending on outside temperature, and the air intake will change to outside (fresh) mode.

To cancel or set the automatic ventilation feature, select Face level mode  and press the air recirculation mode button for 3 seconds.

When the automatic ventilation is set, the air recirculation indicator will blink 6 times. When canceled, the indicator will blink 3 times.

### Sunroof inside air recirculation (if equipped)

When the heater or air conditioning system is on with the sunroof opened, the outside (fresh) air position will be automatically selected. At this time, if you press the recirculated air position button, the recirculated air position will be selected but will change back to the outside (fresh) air position after 3 minutes.

When the sunroof is closed, the air intake position will return to the original position that was selected.

## STORAGE COMPARTMENT

### ⚠ WARNING

Never store cigarette lighters, propane cylinders, or other flammable/explosive materials in the vehicle. These items may catch fire and/or explode if the vehicle is exposed to hot temperatures for extended periods.

### ⚠ WARNING

**ALWAYS** keep the storage compartment covers closed securely while driving. Items inside your vehicle are moving as fast as the vehicle. If you have to stop or turn quickly, or if there is a crash, the items may fly out of the compartment and may cause an injury if they strike the driver or a passenger.

### NOTICE

To avoid possible theft, do not leave valuables in the storage compartments.

## Center console storage

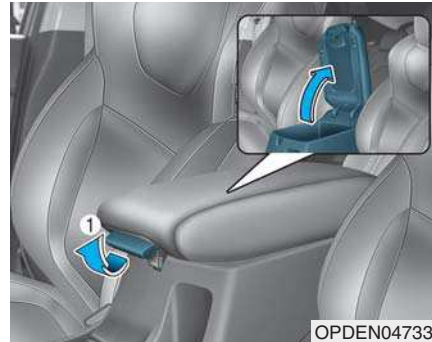

To open :  
Grab and hold the latch (1) on the armrest then lift the lid.

## Glove box



To open the glove box, pull the handle (1) and the glove box will automatically open. Close the glove box after use.

### ⚠ WARNING

**ALWAYS** close the glove box door after use.

An open glove box door can cause serious injury to the passenger in an accident, even if the passenger is wearing a seat belt.



### Sunglass holder

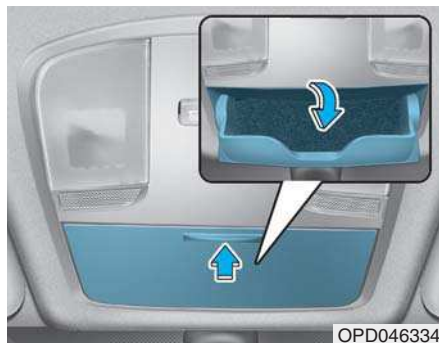

To open:

Press the cover and the holder will slowly open. Place your sunglasses in the compartment door with the lenses facing out.

To close:

Push back into position.

Make sure the sunglass holder is closed while driving.

#### **⚠ WARNING**

- **Do not keep objects except sunglasses inside the sunglass holder. Such objects can be thrown from the holder in the event of a sudden stop or an accident, possibly injuring the passengers in the vehicle.**
- **Do not open the sunglass holder while the vehicle is moving. The rear view mirror of the vehicle can be blocked by an open sunglass holder.**
- **Do not attempt to force sunglasses into the sunglass holder. If the sunglasses become jammed and you try to open it forcibly, personal injury may occur.**

## INTERIOR FEATURES

### Ashtray (if equipped)



To use the ashtray, open the cover.

To clean the ashtray:

The plastic receptacle should be removed by lifting the plastic ashtray receptacle upward after turning the cover counterclockwise and pulling it out.

### WARNING

**Putting lit cigarettes or matches in an ashtray with other combustible materials may cause a fire.**

### Cup holder

#### Front

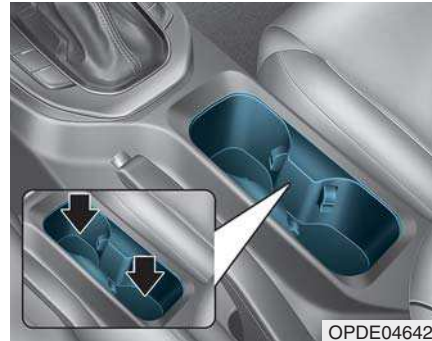

Cups or small beverages cups may be placed in the cup holders.

### Rear (if equipped)

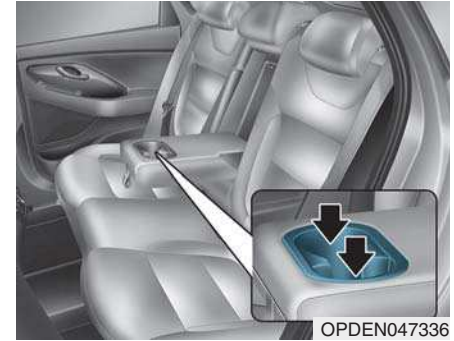

Pull the armrest down to use the cup holders.

### WARNING

- Avoid abrupt starting and braking when the cup holder is in use to prevent spilling your drink. If hot liquid spills, you could be burned. Such a burn to the driver could cause loss of vehicle control resulting in an accident.
- Do not place uncovered or unsecured cups, bottles, cans, etc., in the cup holder containing hot liquid while the vehicle is in motion. Injuries may result in the event of a sudden stop or collision.
- Only use soft cups in the cup holders. Hard objects can injure you in an accident.

### WARNING

Keep cans or bottles out of direct sun light and do not put them in a hot vehicle. It may explode.

### NOTICE

- Keep your drinks sealed while driving to prevent spilling your drink. If liquid spills, it may get into the vehicle's electrical/electronic system and damage electrical/electronic parts.
- When cleaning spilled liquids, do not dry the cup holder at high temperature. This may damage the cup holder.

## Sunvisor

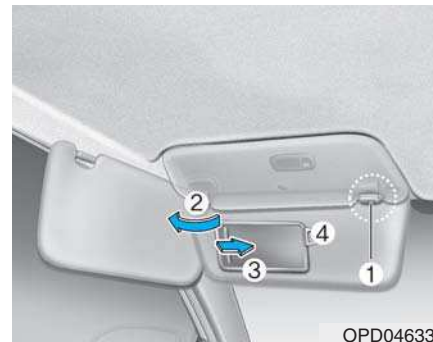

To use a sunvisor, pull it downward.

To use a sunvisor for a side window, pull it downward, unsnap it from the bracket (1) and swing it to the side (2).

To use the vanity mirror, pull down the sunvisor and slide the mirror cover (3).

Use the ticket holder (4) to hold tickets.

### Information

Close the vanity mirror cover securely and return the sunvisor to its original position after use.

**⚠ WARNING**

For your safety, do not block your view when using the sunvisor.

**NOTICE**

Do not put several tickets in the ticket holder at one time. This could cause damage to the ticket holder.

**Power outlet (if equipped)**

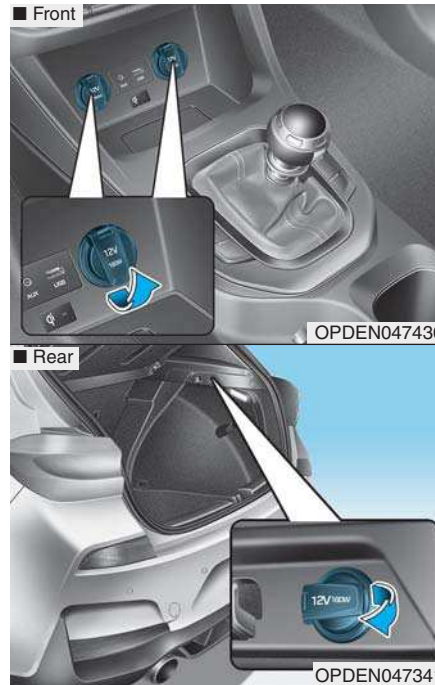

The power outlet is designed to provide power for mobile telephones or other devices designed to operate with vehicle electrical systems.

The devices should draw less than 180 W(Watt) with the engine running.

**⚠ WARNING**

Avoid electrical shocks. Do not place your fingers or foreign objects (pin, etc.) into a power outlet or touch the power outlet with a wet hand.

### NOTICE

To prevent damage to the Power Outlets :

- Use the power outlet only when the engine is running and remove the accessory plug after use. Using the accessory plug for prolonged periods of time with the engine off could cause the battery to discharge.
- Only use 12V electric accessories which are less than 180 W(Watt) in electric capacity.
- Adjust the air-conditioner or heater to the lowest operating level when using the power outlet.
- Close the cover when not in use.

(Continued)

(Continued)

- Some electronic devices can cause electronic interference when plugged into a vehicle's power outlet. These devices may cause excessive audio static and malfunctions in other electronic systems or devices used in your vehicle.
- Push the plug in as far as it will go. If good contact is not made, the plug may overheat and the fuse may open.
- Plug in battery equipped electrical/ electronic devices with reverse current protection. The current from the battery may flow into the vehicle's electrical/electronic system and cause system malfunction.

### Cigarette lighter (if equipped)



To use the cigarette lighter, the ignition switch must be in the ACC or ON position.

Push the cigarette lighter all the way into its socket. When the element is heated, the lighter will pop out to the "ready" position.

We recommend that you use parts for replacement from an authorized HYUNDAI dealer.

## WARNING

- Do not hold the lighter in after it is already heated because it will overheat.
- If the lighter does not pop out within 30 seconds, remove it to prevent overheating.
- Do not insert foreign objects into the socket of the cigarette lighter. It may damage the cigarette lighter.

## NOTICE

Only a genuine HYUNDAI lighter should be used in the cigarette lighter socket. The use of plug-in accessories (shavers, hand-held vacuums, and coffee pots, etc.) may damage the socket or cause electrical failure.

## Wireless cellular phone charging system (if equipped)



There is a wireless cellular phone charger inside the front console.

The system is available when all doors are closed, and when the ignition switch is in the ACC/ON position.

## To charge a cellular phone

The wireless cellular phone charging system charges only the Qi-enabled cellular phones (  ). Read the label on the cellular phone accessory cover or visit your cellular phone manufacturer's website to check whether your cellular phone supports the Qi technology.

The wireless charging process starts when you put a Qi-enabled cellular phone on the wireless charging unit.

1. Remove other items, including the smart key, from the wireless charging unit. If not, the wireless charging process may be interrupted.
2. The indicator light is orange when the phone is charging. The indicator light turns green when phone charging is complete.
3. You can turn ON or OFF the wireless charging function in the User Settings mode on the instrument cluster. For further information, refer to the "LCD Display Modes" in this chapter.

If your phone is not charging:

- Slightly change the position of the cellular phone on the charging pad.
- Make sure the indicator light is orange.

Depending on the cellular phone type, the indicator light may not turn green even though the charging is complete.

The indicator light will blink orange for 10 seconds if there is a malfunction in the wireless charging system.

In this case, temporarily stop the charging process, and re-attempt to wirelessly charge your cellular phone again.

The system warns you with a message on the LCD display if the cellular phone is still on the wireless charging unit after the engine is turned OFF and the front door is opened.

### NOTICE

- **The wireless cellular phone charging system may not support certain cellular phones, which are not verified for the Qi specification ( Qi ).**

(Continued)

(Continued)

- **Locate your cell phone well in the middle of the wireless cellular phone charging system. Even when your cell phone locates slightly to one side, the charging speed may decrease.**
- **The wireless charging process may temporarily stop, when a smart key function operates (i.e. starting the engine, opening the doors, closing the doors).**
- **For certain cell phones, the indicator color may not change to green, even when the wireless charging process is properly completed.**
- **The wireless charging process may temporarily stop, when temperature abnormally increases inside the wireless cellular phone charging system. The wireless charging process restarts, when temperature falls to a certain level.**
- **The wireless charging process may temporarily stop when there is any metallic item, such as a coin, between the wireless cellular phone charging system and a cellular phone.**

## Clock

### WARNING

**Do not adjust the clock while driving. You may lose your steering control and cause severe personal injury or accidents.**

### *Vehicles with Audio system*

Select the [SETUP/CLOCK ] button on the audio system → Select [Date/Time].

- Set time: Set the time displayed on the audio screen.
- Time format: Choose between 12-hour and 24-hour time formats.

### *Vehicles with Navigation system*

Select the Settings menu on the Navigation system → Select [Date/Time].

- GPS time: Displays time according to the received GNSS time.
- 24-hour: Switches to 12 hour or 24 hour.

**For more details, please refer to the separate manual that was supplied with your vehicle.**

## Clothes hanger (if equipped)

■ Type A

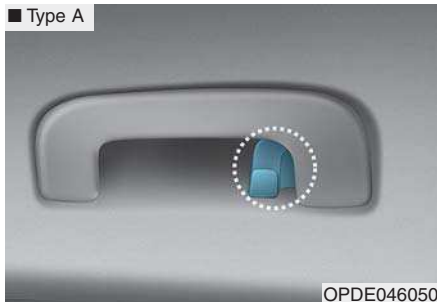

■ Type B

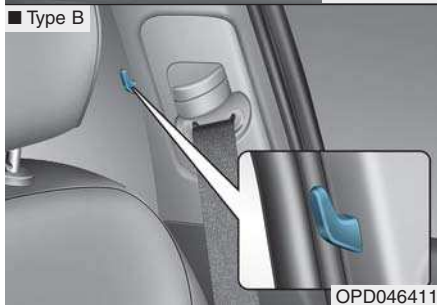

These hangers are not designed to hold large or heavy items.

## ⚠ WARNING



**Do not hang other objects such as hangers or hard objects except clothes. Also, do not put heavy, sharp or breakable objects in the clothes pockets.**

**In an accident or when the curtain air bag is inflated, it may cause vehicle damage or personal injury.**

## Floor mat anchor(s) (if equipped)

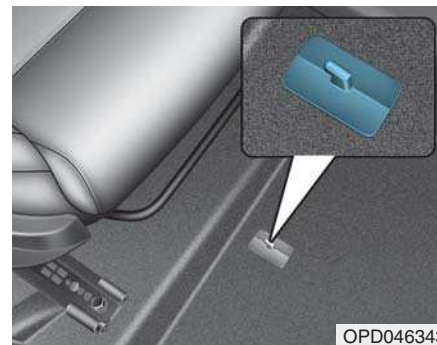

**ALWAYS** use the Floor Mat Anchors to attach the front floor mats to the vehicle. The anchors on the front floor carpet keep the floor mats from sliding forward.

3

Convenient features of your vehicle



**⚠ WARNING**

The following must be observed when installing ANY floor mat to the vehicle.

- Ensure that the floor mats are securely attached to the vehicle's floor mat anchor(s) before driving the vehicle.
- Do not use ANY floor mat that cannot be firmly attached to the vehicle's floor mat anchors.
- Do not stack floor mats on top of one another (e.g. all-weather rubber mat on top of a carpeted floor mat). Only a single floor mat should be installed in each position.

**IMPORTANT** - Your vehicle was manufactured with driver's side floor mat anchors that are designed to securely hold the floor mat in place. To avoid any interference with pedal operation, HYUNDAI recommends that the HYUNDAI floor mat designed for use in your vehicle be installed.

**Luggage net (holder)  
(if equipped)**



To keep items from shifting in the luggage compartment, you can use the four holders located in the luggage compartment, to attach the luggage net.

If necessary, we recommend that you contact your authorized HYUNDAI dealer to obtain a luggage net.

**⚠ CAUTION**

To prevent damage to the goods or the vehicle, care should be taken when carrying fragile or bulky objects in the luggage compartment.

**⚠ WARNING**

To avoid eye injury, **DO NOT** overstretch the luggage net. **ALWAYS** keep your face and body out of the luggage net's recoil path. **DO NOT** use the luggage net when the strap has visible signs of wear or damage.

## Cargo area cover (if equipped)

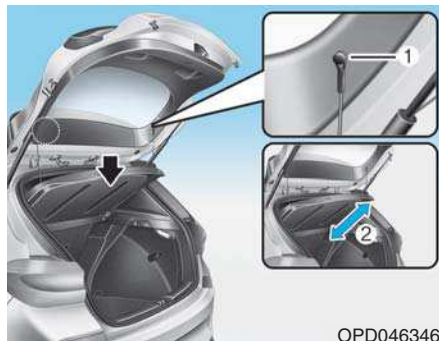

Use the cover to hide items stored in the cargo area.

The cargo area cover will lift when the tailgate is opened.

Disconnect the strap (1) from the holder if you want to return the cover to the original position. To remove the cargo area cover completely, lift the cover to a 50-degree angle and pull it out (2).

### NOTICE

Since the cargo area cover may be damaged or deformed, do not put luggage on it when it is being used.

### ⚠ WARNING

- Do not place objects on the cargo area cover while driving. Such objects may be thrown about inside the vehicle and possibly injure vehicle occupants during an accident or when braking.
- Never allow anyone to ride in the luggage compartment. It is designed for luggage only.
- Maintain balance of the vehicle and locate the weight as far forward as possible.

# Multimedia System

- Multimedia system .....4-2
  - AUX, USB and iPod® port .....4-2
  - Antenna .....4-2
  - Steering wheel audio controls .....4-3
  - Bluetooth*® Wireless Technology hands-free .....4-4
  - Audio / Video / Navigation system (AVN) .....4-4
  - How vehicle radio works .....4-4
- Audio (With Touch Screen) .....4-8**
  - Feature of Your Audio .....4-9
  - Radio .....4-14
  - Media.....4-17
  - Phone.....4-28
  - Setup .....4-36
- Declaration of Conformity.....4-38**
  - CE for EU .....4-38

## MULTIMEDIA SYSTEM

### **i** Information

- If you install an aftermarket HID headlamp, your vehicle's audio and electronic devices may malfunction.
- Prevent chemicals such as perfume, cosmetic oil, sun cream, hand cleaner, and air freshener from contacting the interior parts because they may cause damage or discoloration.

### AUX, USB and iPod® port



You can use an AUX port to connect audio devices and an USB port to plug in an USB and an iPod® port.

### **i** Information

When using a portable audio device connected to the power outlet, noise may occur during playback. If this happens, use the power source of the portable audio device.

\* iPod® is a trademark of Apple Inc.

### Antenna

#### *Shark fin antenna*

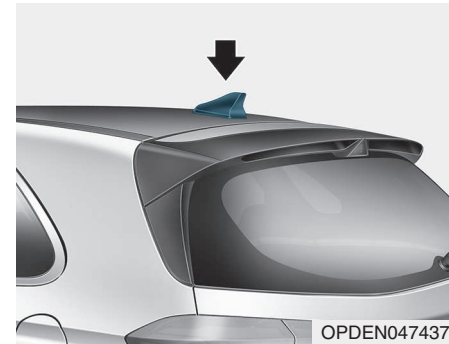

The shark fin antenna receives transmitted data. (for example: AM/FM, DAB, GPS/ GNSS)

## Steering wheel audio controls (if equipped)

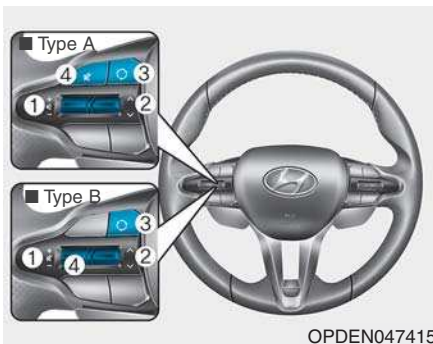

OPDEN047415

The steering wheel audio control switches are installed for your convenience.

### NOTICE

**Do not operate audio remote control buttons simultaneously.**

### VOLUME (VOL + / - ) (1)

- Move the VOLUME toggle switch up to increase volume.
- Move the VOLUME toggle switch down to decrease volume.

### SEEK/PRESET ( ^ / v ) (2)

If the SEEK/PRESET toggle switch is moved up or down and held for 0.8 seconds or more, it will function in the following modes.

#### RADIO mode

It will function as the AUTO SEEK select switch. It will SEEK until you release the switch.

#### MEDIA mode

It will function as the FF/REW switch.

If the SEEK/PRESET toggle switch is moved up or down, it will function in the following modes.

#### RADIO mode

It will function as the PRESET STATION UP/DOWN switch.

#### MEDIA mode

It will function as the TRACK UP/DOWN switch.

### MODE ( ) (3)

Press the MODE button to select Radio, Disc, or AUX.

### MUTE ( ) (4)

- Press the button to mute the sound.
- Press the button again to activate the sound.

### **i** Information

**Detailed information for audio control buttons are described in the following pages in this chapter.**

### Bluetooth® Wireless Technology hands-free



OPDEN047422



OPD046348

You can use the phone wirelessly by using the *Bluetooth®* Wireless Technology.

- (1) Call / Answer button
- (2) Call end button
- (3) Microphone

- Audio : For detailed information, refer to “AUDIO” in this chapter.
- AVN : Detailed information for the *Bluetooth®* Wireless Technology hands-free is described in the manual supplied separately.

### Audio / Video / Navigation system (AVN) (if equipped)

Detailed information for the AVN system is described in a separately supplied manual.

### How vehicle radio works

#### FM reception

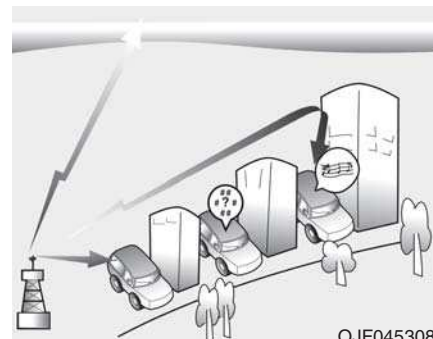

OJF045308L

AM and FM radio signals are broadcast from transmitter towers located around your city. They are intercepted by the radio antenna on your vehicle. This signal is then received by the radio and sent to your vehicle speakers.

When a strong radio signal has reached your vehicle, the precise engineering of your audio system ensures the best possible quality reproduction. However, in some cases the signal coming to your vehicle may not be strong and clear.

This can be due to factors, such as the distance from the radio station, closeness of other strong radio stations or the presence of buildings, bridges or other large obstructions in the area.

### **AM (MW, LW) reception**

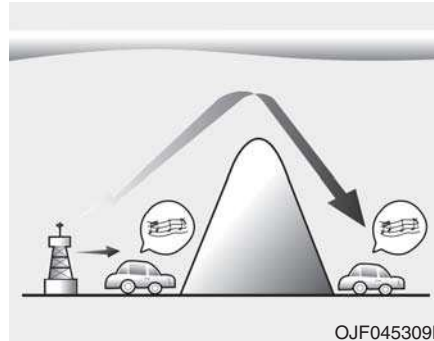

AM broadcasts can be received at greater distances than FM broadcasts. This is because AM radio waves are transmitted at low frequencies. These long, low frequency radio waves can follow the curvature of the earth rather than travelling straight out into the atmosphere. In addition, they curve around obstructions so that they can provide better signal coverage.

### **FM radio station**

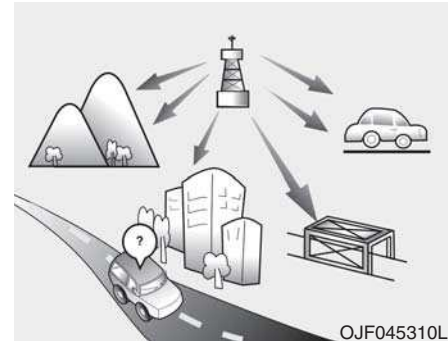

FM broadcasts are transmitted at high frequencies and do not bend to follow the earth's surface. Because of this, FM broadcasts generally begin to fade at short distances from the station. Also, FM signals are easily affected by buildings, mountains, or other obstructions. These can result in certain listening conditions which might lead you to believe a problem exists with your radio. The following conditions are normal and do not indicate radio trouble :

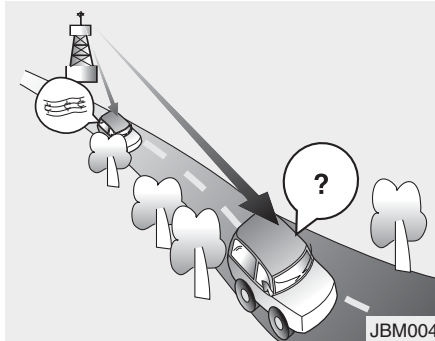

- **Fading** - As your vehicle moves away from the radio station, the signal will weaken and sound will begin to fade. When this occurs, we suggest that you select another stronger station.
- **Flutter/Static** - Weak FM signals or large obstructions between the transmitter and your radio can disturb the signal causing static or fluttering noises to occur. Reducing the treble level may lessen this effect until the disturbance clears.

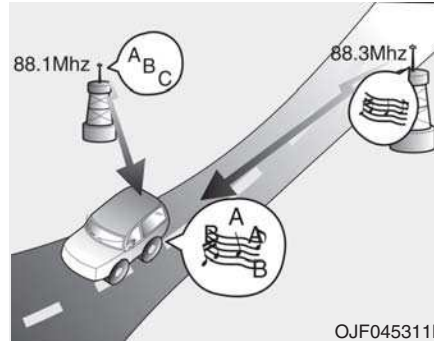

- **Station Swapping** - As a FM signal weakens, another more powerful signal near the same frequency may begin to play. This is because your radio is designed to lock onto the clearest signal. If this occurs, select another station with a stronger signal.
- **Multi-Path Cancellation** - Radio signals being received from several directions can cause distortion or fluttering. This can be caused by a direct and reflected signal from the same station, or by signals from two stations with close frequencies. If this occurs, select another station until the condition has passed.

### **Using a cellular phone or a two-way radio**

When a cellular phone is used inside the vehicle, noise may be produced from the audio system. This does not mean that something is wrong with the audio equipment. In such a case, use the cellular phone at a place as far as possible from the audio equipment.

#### **NOTICE**

**When using a communication system such as a cellular phone or a radio set inside the vehicle, a separate external antenna must be fitted. When a cellular phone or a radio set is used with an internal antenna alone, it may interfere with the vehicle's electrical system and adversely affect safe operation of the vehicle.**

#### **⚠ WARNING**

**Do not use a cellular phone while driving. Stop at a safe location to use a cellular phone.**



---

## iPod®

---

iPod® is a registered trademark of Apple Inc.

---

## Bluetooth® Wireless Technology

---

The Bluetooth® word mark and logos are registered trademarks owned by Bluetooth SIG, Inc. and any use of such marks by HYUNDAI is under license.

Other trademarks and trade names are those of their respective owners.

A *Bluetooth®* Wireless Technology enabled cell phone is required to use *Bluetooth®* Wireless Technology.



## AUDIO (With Touch Screen)

■ Type A



■ Type B



(With *Bluetooth*® Wireless Technology)

S0H4H0000EE/S0H4H0001EE

## Feature of Your Audio

### Head unit

#### ■ Type A

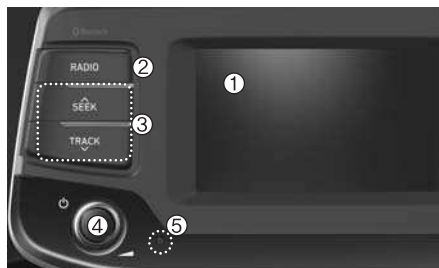

#### ■ Type B

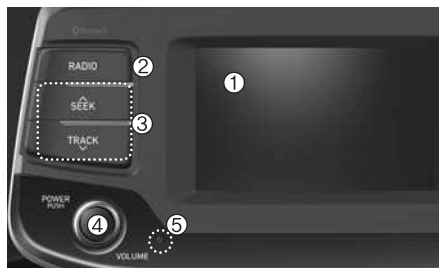

\* The actual features in the vehicle may differ from the illustration.

#### (1) LCD screen

- Tap the screen to select a button.

#### (2) RADIO

- Start DAB/FM\* and AM radio.

\* with DAB

#### (3) SEEK/TRACK

- Search for next station in DAB/FM\* and AM radio mode.
- Change the current song in media mode.

\* with DAB

#### (4) POWER/VOLUME knob

- Turn to adjust the volume.
- Press to turn the device on or off.

#### (5) RESET

- Shutdown and restart the system.

### ■ Type A



### ■ Type B



### (6) **MEDIA**

- Select USB(iPod®), Bluetooth®(BT) Audio, AUX or My Music.
- Display the media menu when two or more media are connected or when the **[MEDIA]** button is pressed in media mode.

### (7) **PHONE**

- Start Bluetooth® Phone mode.

### (8) **SETUP**

- Access Display, Sound, Date/Time, Bluetooth, System, Screensaver and Display Off settings.

### (9) **TUNE** knob

- Turn to navigate through the stations/songs list.
- Press to select an item.

### Steering wheel remote control



※ The actual features in the vehicle may differ from the illustration.

#### (1) MUTE

- Mutes the audio.
- Mutes the microphone during a call.

#### (2) MODE

- Press the button to change the mode in the following order: Radio → Media.

#### (3) VOLUME

- Press to adjust the volume.

#### (4) UP/DOWN

- Press the button in radio mode to search Presets.
- Press and hold the button in radio mode to search frequencies.
- Press the button in media mode to change the current song.(except AUX)
- Press and hold the button in media mode to quick search through songs. (except Bluetooth®(BT) Audio and AUX)

#### (5) CALL

- Pressing the button
  - If not in Bluetooth® Handsfree mode or receiving a phone call.
    - First press: Display Dial Number screen.
    - Second press: Automatically display the most recently Dialed Call number.
    - Third press: Dial the phone number entered.
  - Press in the Incoming Call notification screen to accept the phone call.
  - Press in Bluetooth® Handsfree mode to switch to the waiting call.

- Pressing and holding the button (more than 1.0 seconds)
  - If not in Bluetooth® Handsfree mode or receiving a phone call, the most recently Dialed Call number is dialed.
  - Press in Bluetooth® Handsfree mode to transfer the call to your cell phone.
  - Press in cell phone mode to switch to Bluetooth® Handsfree mode.

#### (6) END

- Press in Bluetooth® Handsfree mode to end the phone call.
- Press in the incoming call screen to reject the call.

 **WARNING**

- Do not stare at the screen while driving. Staring at the screen for prolonged periods of time could lead to traffic accidents.
- Do not disassemble, assemble, or modify the audio system. Such acts could result in accidents, fire, or electric shock.
- Using the phone while driving may lead to a lack of attention of traffic conditions and increase the likelihood of accidents. Use the phone feature after parking the vehicle.
- Exercise caution not to spill water or introduce foreign objects into the device. Such acts could lead to smoke, fire, or product malfunction.

(Continued)

(Continued)

- Please refrain from use if the screen is blank or no sound can be heard as these signs may indicate product malfunction. Continued use in such conditions could lead to accidents (fires, electric shock) or product malfunctions.
- Do not touch the antenna during thunder or lightening as such acts may lead to lightning induced electric shock.
- Do not stop or park in parking-restricted areas to operate the product. Such acts could lead to traffic accidents.
- Use the system with the vehicle engine turned on. Prolonged use with the ignition turned on only could result in battery discharge.

 **WARNING**

Driving while distracted can result in a loss of vehicle control that may lead to an accident, severe personal injury, and death. The driver's primary responsibility is in the safe and legal operation of a vehicle, and use of any handheld devices, other equipment, or vehicle systems which take the driver's eyes, attention and focus away from the safe operation of a vehicle or which are not permissible by law should never be used during operation of the vehicle.

## **NOTICE**

- Operating the device while driving could lead to accidents due to a lack of attention to external surroundings. First park the vehicle before operating the device.
- Adjust the volume to levels that allow the driver to hear sounds from outside of the vehicle. Driving in a state where external sounds cannot be heard may lead to accidents.
- Pay attention to the volume setting when turning the device on. A sudden output of extreme volume upon turning the device on could lead to hearing impairment. (Adjust the volume to a suitable levels before turning off the device.)

(Continued)

(Continued)

- Turn on the car engine before using this device. Do not operate the audio system for long periods of time only with the ignition turned on as such operations may lead to battery discharge.
- Do not subject the device to severe shock or impact. Direct pressure onto the front side of the monitor may cause damage to the LCD.
- When cleaning the device, make sure to turn off the device and use a dry and smooth cloth. Never use tough materials, chemical cloths, or solvents (alcohol, benzene, thinners, etc.). As such materials may damage the device panel or cause color/quality deterioration.











(Continued)

(Continued)

- Do not place beverages close to the audio system. Spilling beverages may lead to system malfunction.
- In case of product malfunction, please contact your place of purchase or After Service center.
- Placing the audio system within an electromagnetic environment may result in noise interference.
- Prevent caustic solutions such as perfume and cosmetic oil from contacting the dashboard because they may cause damage or discoloration.

### Information on status icons

Icons showing audio status are shown in the upper-right corner of the screen.

Icon	Description
	Mute Mute engaged
	Battery Remaining battery life of a connected Bluetooth® device
	Handsfree + Audio streaming connection Bluetooth® Handsfree call and audio streaming available
	Handsfree connection Bluetooth® Handsfree call available
	Bluetooth® audio streaming Bluetooth® audio streaming available
	Downloading contacts Downloading contacts through Bluetooth® wireless communications
	Downloading call history Downloading call history through Bluetooth® wireless communications
	Line busy Phone call in progress
	Mute mic Mic muted during a call (caller cannot hear your voice)
	Phone signal strength Display the phone signal strength for a cell phone connected by Bluetooth®

### Radio

#### FM/AM (with RDS)



#### (1) Radio

Switch between FM and AM.

#### (2) List

View all available stations.

#### (3) Presets

View all presets.

#### (4) Menu

Navigate to the menu screen.

### Switching between FM and AM

- Press the **[RADIO]** button on the audio system to switch between FM and AM.
- Select [Radio] on the screen to switch between FM and AM.

### Searching stations

Press the **[SEEK/TRACK]** button to search stations.

### List

A list of all available stations in the vehicle's current location is displayed. Select the desired station.

Favourite stations can be saved to [Presets] by selecting [+].



### Presets

Save up to 40 frequently used stations. To listen to a preset, select the desired station list.

Press and hold the desired slot from 1 through 40. This saves the current station in the selected slot.

If the slot is empty, simply selecting saves the station to the slot.

### Menu

Select [Menu], and select the desired function.

- Traffic Announcement (TA): Enable or disable Traffic Announcements.
- Scan: All available stations are played for five seconds each.
- Sound Settings: Audio sound settings can be changed.

### DAB/FM (with DAB)



#### (1) Radio

Switch between DAB/FM and AM.

#### (2) List

View all available stations.

#### (3) Presets

View all presets.

#### (4) Menu

Navigate to the menu screen.

### Switching between DAB/FM and AM

- Press the **[RADIO]** button on the audio system to switch between DAB/FM and AM.
- Select [Radio] on the screen to switch between DAB/FM and AM.

### Searching stations

Press the **[SEEK/TRACK]** button to search stations.

### List

A list of all available stations in the vehicle's current location is displayed. Select the desired station.

Favourite stations can be saved to [Presets] by selecting [+].

### Presets

Save up to 40 frequently used stations. To listen to a preset, select the desired station list.

Press and hold the desired slot from 1 through 40. This saves the current station in the selected slot.

If the slot is empty, simply selecting saves the station to the slot.

### Menu

Select [Menu], and select the desired function.

- Traffic Announcement (TA): Enable or disable Traffic Announcements.
- Region : Enable or disable automatic switching between regional stations.
- Scan: All available stations are played for five seconds each.
- Sound Settings: Audio sound settings can be changed.
- Manual tune FM : Search for frequencies manually.

### FM/AM (without RDS)



#### (1) Band

Switch between FM and AM.

#### (2) Presets

View all presets.

#### (3) List

View all available stations.

#### (4) Menu

Navigate to the menu screen.

### Switching between FM and AM

- Press the [**RADIO**] button on the audio system to switch between FM and AM.
- Select [Band] on the screen to switch between FM and AM.

### Searching stations

Press the [**SEEK/TRACK**] button to search stations.

### List

A list of all available stations in the vehicle's current location is displayed. Press the desired station.

Favourite stations can be saved to [Presets] by selecting [save].

## Presets

Save up to 40 frequently used stations.

To listen to a preset, select the desired station list.

Press and hold the desired slot from 1 through 40. This saves the current station in the selected slot.

If the slot is empty, simply selecting saves the station to the slot.

## Menu

Select [Menu], and select the desired function.

- Scan: All available stations are played for five seconds each.
- Sound Settings: Audio sound settings can be changed.

## Media

### **i** Information - Using MP3

#### Supported audio formats

Audio formats	WAVEform audio format
Compressed audio formats	MPEG1 Audio Layer3
	MPEG2 Audio Layer3
	MPEG2.5 Audio Layer3
	Windows Media Audio Ver 7.X & 8.X

#### **NOTICE**

**File formats other than the formats above may not be recognized or playable. Information such as filename may not be displayed.**

## Range of supported compressed file types

### 1. Bitrate range (Kbps)

BIT RATE(kbps)	MPEG1	MPEG2	MPEG2.5	WMA
	Layer3			High Range
	32	8	8	48
	40	16	16	64
	48	24	24	80
	56	32	32	96
	64	40	40	128
	80	48	48	160
	96	56	56	192
	112	64	64	
	128	80	80	
	160	96	96	
	192	112	112	
	224	128	128	
	256	144	144	
	320	160	160	
	WAV			
	PCM(Stereo)	IMA ADPCM	MS ADPCM	
	24	4	4	

### 2. Sampling frequency (Hz)

MPEG1	MPEG2	MPEG2.5	WMA	WAV
44100	22050	11025	32000	44100
48000	24000	12000	44100	48000
32000	16000	8000	48000	

- The sound quality of MP3/WMA compressed and WAV files may vary depending on the bitrate. (A higher bitrate can have better sound quality.)
- The product only recognizes files with the MP3, WMA or WAV extension. Files without one of these extensions are not recognized.

### 3. Number of recognizable folders and files

- Folders: 2,000 for USB
- Files: 6,000 for USB
- No recognition limit for folder hierarchies.

### 4. Character display range (Unicode)

- Filenames: Up to 64 English characters (64 Korean characters)
- Folder names: Up to 32 English characters (32 Korean characters)

#### Languages supported (Unicode support)

- Korean: 2,604 characters
- English: 94 characters
- Common Chinese characters: 4,888 characters
- Special symbols: 986 characters

#### **NOTICE**

**Japanese/Simplified Chinese characters are not supported.**

#### **i Information**

##### **- Using the USB Devices**

- Starting the vehicle while a USB device is connected can damage the device. Please disconnect USB devices before starting the vehicle.
- Starting the vehicle or stopping the engine while an external USB device is connected can result in failure of the external USB device to operate.
- Be cautious of static electricity when connecting/disconnecting external USB devices.
- An encrypted MP3 player is not recognized when connected as an external device.
- External USB devices may not be recognized, depending on the state of the external USB device.
- Only products with byte/sectors formatted at 4 KB or lower are recognized.
- Only USB devices in FAT12/16/32 format are recognized; NTFS and ExFAT file systems are not recognized.

(Continued)

**(Continued)**

- Some USB devices are not recognized due to compatibility issues.
- Do not touch the USB connections.
- Connecting and disconnecting USB devices rapidly over a short period of time can cause equipment failure.
- Abnormal sounds may be audible when the USB device is disconnected.
- Turn the audio off before connecting or disconnecting external USB devices.
- Recognition may take longer depending on the type, capacity or file format of the external USB device. This is not a product malfunction.
- Use of USB devices for purposes other than playing music files is prohibited.
- Image display and video playback are not supported.

**(Continued)****(Continued)**

- Use of USB accessories, including charge and heat though the USB I/F, can lead to reduced product performance or malfunctions. Do not use USB devices or accessories for these purposes.
- Use of aftermarket USB hubs and extension cables can result in the vehicle's audio system failing to recognize your USB device. Connect the USB device directly to the multimedia port of your vehicle.
- When using high-capacity USB devices with logical drive divisions, only files saved on the highest level logical drive can be played.  
If applications are loaded on a USB drive, file playback may fail.
- Some MP3 players, cell phones, digital cameras, etc. (USB devices that are not recognized as mobile storage) may not operate normally when connected.
- USB charging may not be supported by some mobile devices.

**(Continued)****(Continued)**

- Operation is guaranteed only for standard (Metal Cover Type) USB Memory drives.
- Operation of HDD, CF, SD and memory stick devices is not guaranteed.
- DRM (Digital Rights Management) files cannot be played.
- SD-type USB memory, CF-type USB memory, and other USB memory devices that require adapters for connection are not supported.
- Proper operation of USB HDDs or USB drives with connectors that loosen due to vehicle vibrations is not guaranteed. (iStick, etc.)
- USB products that are used as key chains or cell phone accessories may damage the USB jack and affect proper file playback. Please refrain from use. Use only products with plug connectors, as shown in the following illustration.
- When MP3 devices or cell phones are connected simultaneously through AUX, BT Audio and USB modes, a popping noise or malfunction may occur.



### USB

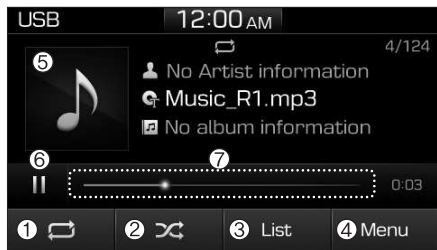

#### (1) Repeat

Enable/disable repeat.

#### (2) Shuffle

Enable/disable shuffle play.

#### (3) List

View a list of all songs.

#### (4) Menu

Navigate to the menu screen.

#### (5) Album Image

View song info.

#### (6) Pause

Pause or play music.

#### (7) Playback progress

Select to skip to the desired location.

### Playback

- Press the **[MEDIA]** button, and select **[USB]**.
- Connect a USB drive to the USB port to automatically play files on the USB drive.

### Changing songs

- Press the **[SEEK/TRACK]** button to play the previous or next song.
- Press and hold the **[SEEK/TRACK]** button to rewind or fast forward the currently playing song.
- Search songs by turning **TUNE** knob, and press the knob to play.

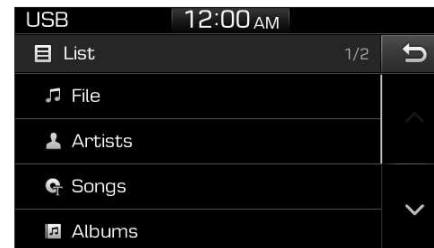

### Selecting songs from a list

Select **[List]** to see a list of songs available for play.

Select and play the desired song.

### Repeat play

Select **[Repeat]** to enable or disable 'Repeat all', 'Repeat current song', 'Repeat folder' or 'Repeat category' play.



- Repeat all: All songs in the playlist are repeated.
- Repeat current song: The currently playing song is repeated.
- Repeat folder: All songs in the current folder are repeated.
- Repeat category: Repeat all songs in the current category.

## **i** Information

The repeat folder function is available only when songs are playing from the [File] category under [List].

### Shuffle play

Select [Shuffle] to enable or disable 'Shuffle', 'Shuffle folder' or 'Shuffle category' play.

-  Shuffle: Songs are played in random order.
-  Shuffle folder: Songs within the current folder are played in random order
-  Shuffle category: Songs within the current category are played in random order.

### Menu

Select [Menu], and select the desired function.

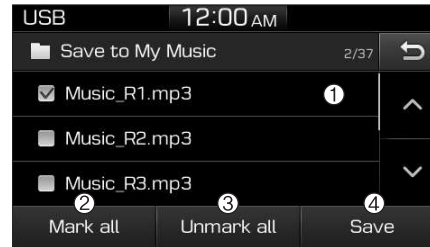

- Save to My Music: Songs on your USB device can be saved to My Music.

- (1) File: Select a file to save.
- (2) Mark all: Select all files.
- (3) Unmark all: Deselect all files.

- (4) Save: Save the selected file(s).

- Select the files you want to save, and select [Save]. This saves the selected files to My Music.
- Saving is canceled if phone calls are received or made while saving.
- Up to 6,000 files can be saved.
- The currently playing file on the USB device cannot be changed while saving.
- My Music cannot be used while saving.
- Up to 700 MB can be saved.
- Information: Detailed information on the currently playing song is displayed.
- Sound Settings: Audio sound settings can be changed.

### **i** Information

#### - Using the iPod® Devices

- To use the audio system's iPod® control function, use the dedicated cable provided with your iPod®.
- Connecting the iPod® to the vehicle during play may result in a loud noise that lasts about one to two seconds. Connect the iPod® to the vehicle after stopping or pausing play.
- Connect the iPod® with the vehicle in the ACC ON state to begin charging.
- When connecting the iPod® cable, be sure to fully push the cable into the port.
- When EQ effects are enabled simultaneously on external devices, such as iPod®s and the audio system, the EQ effects may overlap, causing sound quality deterioration or distortion. Deactivate the EQ function for all external devices, if possible.
- Noise may occur when your iPod® or the AUX port is connected. Disconnect and store separately when not in use.

(Continued)

(Continued)

- There may be noise if the audio system is used with an iPod® or AUX external device connected to the power jack. In these cases, disconnect the iPod® or external device from the power jack.
- Play may be interrupted, or device malfunctions may occur depending on the characteristics of your iPod®/iPhone®.
- Play may fail if your iPhone® is connected through both Bluetooth® and USB. In this case, select Dock connector or Bluetooth® on your iPhone® to change the sound output settings.
- If your software version does not support the communication protocol or your iPod® is not recognized due to device failure, anomalies or defects, iPod® mode cannot be used.
- iPod® nano (5th generation) devices may not be recognized if the battery is low. Charge sufficiently before use.

(Continued)

(Continued)

- The search and song play order in the iPod® device may be different from the search order in the audio system.
- If the iPod® has failed due to an internal defect, please reset the iPod® (consult your iPod® manual).
- Depending on the software version, the iPod® may fail to sync with the system. If the media is removed or disconnected before recognition, the previous mode may not be restored (iPad® cannot be charged).
- Cables other than the 1-meter cable provided with iPod®/iPhone® products may not be recognized.
- When other music apps are used on your iPod®, the system sync function may fail due to malfunction of the iPod® application.

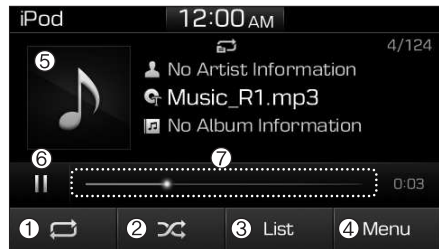

**iPod®****(1) Repeat**

Enable/disable repeat play.

**(2) Shuffle**

Enable/disable shuffle play.

**(3) List**

View a list of all songs.

**(4) Menu**

Navigate to the menu screen.

**(5) Album Image**

View song info.

**(6) Pause**

Pause or play music.

**(7) Playback progress**

Select to skip to the desired location.

**Playback**

- Connect your iPod® to the audio USB port, press the **[MEDIA]** button, and select [iPod].

**Changing songs**

- Press the **[SEEK/TRACK]** button to play the previous or next song.
- Press and hold the **[SEEK/TRACK]** button to rewind or fast forward the currently playing song.
- Search songs by turning the **TUNE** knob, and press the knob to play.

**Selecting songs from a list**

Select [List] to see a list of songs available for play.

Select and play the desired song.

**Repeat play**

Select [Repeat] to enable or disable 'Repeat category', 'Repeat current song' play.

- Repeat category: Repeat all songs in the current category.
- Repeat current song: The currently playing song is repeated.

**Shuffle play**

Select [Shuffle] to enable or disable 'Shuffle category' play.

- Shuffle category: Songs within the current category are played in random order.

**Menu**

Select [Menu], and select the desired function.

- Information: Detailed info on the currently playing song is displayed.
- Sound Settings: Audio sound settings can be changed.

### When other music programs are running

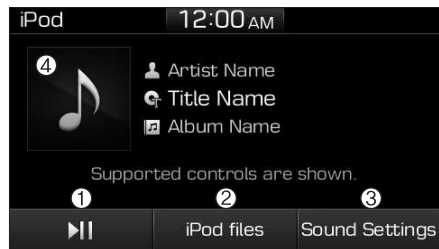

When songs saved on your iPod® are playing through a separate music app, the above screen is displayed.

- (1) Play/Pause: Pause or play music.
- (2) iPod files: Play music saved on your iPod®.
- (3) Sound Settings: Audio sound settings can be changed.
- (4) Album Image: View playback info.

### Playing iPod files

- Select [iPod files] to play songs saved on your iPod®.

If there are no songs saved on your iPod®, the [iPod files] is disabled.

### **i** Information

Operation cannot be carried out correctly due to iPod® application malfunction.

### **i** Information

#### - Using Bluetooth® (BT) Audio

- Bluetooth® Audio mode can only be used if a Bluetooth®-enabled phone is connected. Only devices that support Bluetooth® audio can be used.
- If the Bluetooth®-enabled phone is disconnected during play, the music stops.
- When the TRACK UP/DOWN buttons are used during Bluetooth® audio streaming, a popping noise or sound interruptions may occur, depending on the cell phone device.
- Depending on the cell phone model, the audio streaming function may not be supported.
- If a phone call is made or received when music is playing in Bluetooth® Audio mode, the call may mix with the music.
- When returning to Bluetooth® Audio mode after ending a call, play might not resume automatically for some cell phone models.

**NOTICE**

- **Bluetooth® Handsfree** is a feature that enables drivers to practice safe driving. Connecting the car audio system with a Bluetooth® phone allows the user to conveniently make calls, receive calls, and manage the phone book. Before using the **Bluetooth® Wireless Technology**, carefully read the contents of this user's manual.
- **Excessive use or operations while driving** may lead to negligent driving practices and be the cause of accidents.
- **Do not operate the device excessively while driving.**
- **Viewing the screen for prolonged periods of time is dangerous and may lead to accidents.**
- **When driving, view the screen only for short periods of time.**

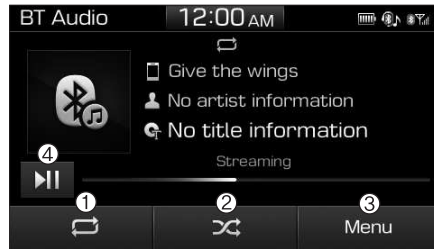
**Bluetooth® (BT) Audio**

- (1) **Repeat**  
Enable/disable repeat play.
- (2) **Shuffle**  
Enable/disable shuffle play.
- (3) **Menu**  
Navigate to the menu screen.
- (4) **Play/Pause**  
Pause or play music.

**i Information**

- Some cell phone models may not support particular functions.
- Bluetooth® audio volume is synced with cell phone media volume.

**Playback**

- Press the **[MEDIA]** button, and select **[BT Audio]**.

**Changing songs**

- Press the **[SEEK/TRACK]** button to play the previous or next song.

**i Information**

Some cell phones may not support this function.

**Repeat play**

Select **[Repeat]** to enable or disable 'Repeat all', 'Repeat current song' or 'Repeat category' play.



- Repeat all: All songs in the playlist are repeated.
- Repeat current song: The currently playing song is repeated.
- Repeat category: Repeat all songs in the current category.

### **i** Information

The repeat play function is engaged, depending on the operation of the connected Bluetooth® device.

### Shuffle play

Select [Shuffle] to enable or disable 'Shuffle', 'Shuffle category' play.

-  Shuffle: Songs are played in random order.
-  Shuffle category: Songs within the current category are played in random order.

### **i** Information

The shuffle function is engaged, depending on the operation of the connected Bluetooth® device.

### Menu

Select [Menu], and select the desired function.

- Connections: The currently connected Bluetooth® device can be changed.
- Information: Detailed information on the currently playing song is displayed.
- Sound Settings: Audio sound settings can be changed.

## AUX

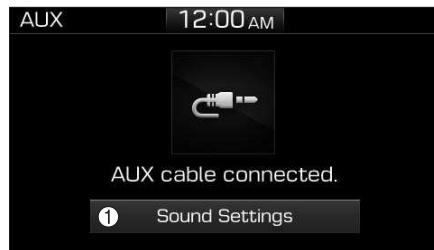

### Running AUX

- Press the [MEDIA] button, and select [AUX].
- Connect the external device connection jack to the AUX terminal to run AUX.

(1) Sound Settings: Audio sound settings can be changed.

## My Music

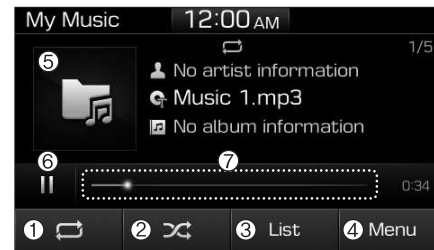

### (1) Repeat

Enable/disable repeat play.

### (2) Shuffle

Enable/disable shuffle play.

### (3) List

View a list of all songs.

### (4) Menu

Navigate to the menu screen.

### (5) Album Image

View song info.

### (6) Pause

Pause or play music.

### (7) Playback progress

Select to skip to the desired location.

### Playback

Press the **[MEDIA]** button, and select [My Music].

- My Music cannot be selected if it does not contain music.
- Check the content of your USB drive before saving music to My Music.

### Changing songs

Press the **[SEEK/TRACK]** button to play the previous or next song.

- Press and hold the **[SEEK/TRACK]** button to rewind or fast forward the currently playing song.
- Search songs by turning the **TUNE** knob and press the knob to play.

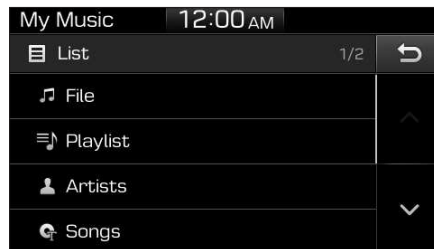

### Selecting songs from a list

Select [List] to see a list of songs available for play.

Select and play the desired song.

### Repeat play

Select [Repeat] to enable or disable 'Repeat all', 'Repeat current song' or 'Repeat category' play.

- Repeat all: All songs in the playlist are repeated.
- Repeat current song: The currently playing song is repeated.
- Repeat category: Repeat all songs in the current category.

### Shuffle play

Select [Shuffle] to enable or disable 'Shuffle', 'Shuffle category' play.

- Shuffle: Songs are played in random order.
- Shuffle category: Songs within the current category are played in random order.

### Menu

Select [Menu], and select the desired function.

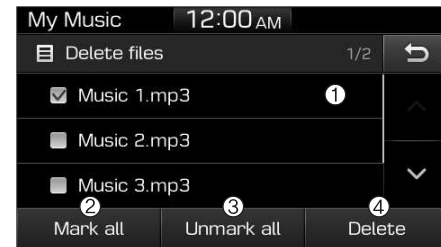

- Delete files: You can delete files from My Music.

- (1) File: Select saved file.
- (2) Mark all: Select all files.
- (3) Unmark all: Deselect all files.

- (4) Delete: Delete the selected file(s).
- Select the file to delete, then select [Delete] to delete it.
  - Delete is canceled if phone calls are received or made during delete.
- Add to playlist: Frequently played songs can be paired in a [Playlist].
    - Songs can be played from the [Playlist].
  - Information: Detailed info on the currently playing song is displayed.
  - Sound Settings: Audio sound settings can be changed.

### Delete from playlist

When a song in the playlist is playing, select [Menu] and select [Delete from playlist].

Select the song to delete, then select [Delete].

## Phone

### **i** Information

#### - Using Bluetooth® (BT) Phone

- **Bluetooth® is a near-field wireless networking technology that uses the 2.4 GHz frequency to connect various devices within a certain distance wirelessly.**
- **The technology is used in PCs, peripherals, Bluetooth® phones, tablet PCs, household appliances and automobiles. Devices supporting Bluetooth® can exchange data at high speeds without physical cable connections.**
- **Bluetooth® Handsfree devices enable convenient access to phone functions through cell phones equipped with Bluetooth®.**
- **Some Bluetooth® devices may not be supported by the Bluetooth® Handsfree function.**

(Continued)

(Continued)

- **When Bluetooth® is connected and calls are attempted through a connected cell phone from outside the vehicle, the call is connected through the Bluetooth® Handsfree function of the vehicle.**
- **Please be sure to disconnect the Bluetooth® Handsfree function through your Bluetooth® device or the audio screen.**

### Safety precautions

- The Bluetooth® Handsfree function helps drivers to drive safely. By connecting a Bluetooth®-enabled phone to the vehicle's audio system, phone calls can be made and received through the audio system and contacts can be managed. Consult the user manual before use.
- Excessive manipulation of controls while driving, making it difficult to pay attention to the road ahead, can lead to accidents. Do not operate the device excessively while driving.
- Looking at the screen for a prolonged time increases the risk of accidents. Keep time spent looking at the screen to a minimum.

### Precautions when connecting Bluetooth® devices

- The vehicle supports the following Bluetooth® functions. Some Bluetooth® devices may not support some functions.
  - 1) Bluetooth® Handsfree phone calls
  - 2) Operations during a call (Private, Switch, Mic Vol. controls)
  - 3) Download call history saved to the Bluetooth® device
  - 4) Download contacts saved to the Bluetooth® device
  - 5) Automatic contacts/call history download when Bluetooth® is connected
  - 6) Automatic Bluetooth® device connection when the vehicle is started
  - 7) Bluetooth® audio streaming playback
- Before connecting the audio system to your device, make sure your device supports Bluetooth®.
- Even if your device supports Bluetooth®, a Bluetooth® connection cannot be established if the device's Bluetooth® function is switched off. Search and connect with the Bluetooth® function enabled.
- Pair or connect Bluetooth® devices to the audio system with the vehicle at a standstill.
- If a Bluetooth® connection is lost due to abnormal conditions while a Bluetooth® device is connected (communication range exceeded, device power OFF, communication errors, etc.), the disconnected Bluetooth® device is searched for and automatically reconnected.
- If you want to disable the Bluetooth® device auto-connect function, turn the Bluetooth® function OFF on your device. Consult the user manuals for individual devices to see whether Bluetooth® is supported.
- Handsfree call quality and volume may vary depending on the type of Bluetooth® device.

- Some Bluetooth® devices are subject to intermittent Bluetooth® connection failures. In this case, use the following method.

- 1) Turn the Bluetooth® function off on your Bluetooth® device → Turn it on and try again.
- 2) Delete the paired device from both the audio system and Bluetooth® device, then pair again.
- 3) Power down your Bluetooth® device → Turn it on and try again.
- 4) Completely remove the battery from your Bluetooth® device; reinsert it, reboot, and attempt connection.
- 5) Restart the vehicle and reattempt connection.

### **i** Information

**Maximum power output of Bluetooth is 3mW.**

### **Pairing a Bluetooth® device**

#### Information on pairing Bluetooth® devices

- Pairing refers to the process of pairing Bluetooth® cell phones or devices with the system prior to connection. This is a necessary procedure for Bluetooth® connection and usage.
- Up to five devices can be paired.
- Pairing Bluetooth® device is not allowed while vehicle is moving.

#### Pairing the first Bluetooth® device

Press the **[PHONE]** button on the audio system or the **[CALL]** button on the steering wheel remote control → Search for the vehicle from the Bluetooth® device, and pair → Enter the passkey on the Bluetooth® device or approve passkey → Bluetooth® pairing completed.

1. When the **[PHONE]** button on the audio or the **[CALL]** button on the steering wheel remote control is pressed, the following screen is displayed. Devices can now be paired.

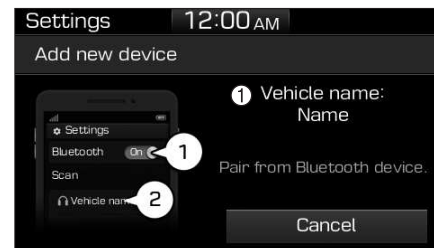

- (1) Vehicle name: Searched name in Bluetooth® device.

### **i** Information

**The vehicle name in the image above is an example. Refer to your device for the actual name of your device.**

2. Search for available Bluetooth® devices in the Bluetooth® menu of your Bluetooth® device (cell phone, etc.).
3. Confirm that the vehicle name in your Bluetooth® device matches the vehicle name shown on the audio screen, then select it.



- 4-1. For devices that require passkey entry, a passkey entry screen is shown on your Bluetooth® device.
- Enter the passkey '0000', in your Bluetooth® device.
- 4-2. For devices that require passkey confirmation, the following screen is shown on the audio system. A 6-digit passkey input screen is shown in the Bluetooth® device.

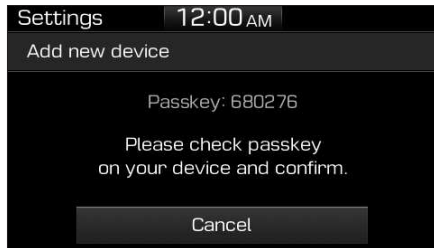

- After confirming that the 6-digit passkey on the audio screen and the Bluetooth® device are identical, select [OK] in your Bluetooth® device.

### **i** Information

The 6-digit passkey in the image above is an example. Refer to your vehicle for the actual passkey.

### Pairing a second Bluetooth® device

Press the [SETUP] button on the audio system → Select [Bluetooth] → Select [Connections] → Select [Add new].

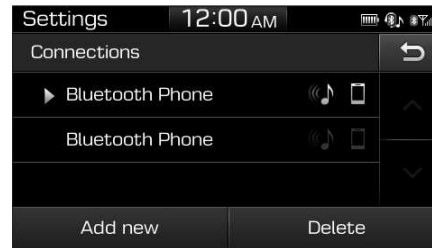

- The pairing procedure from this point is identical to [Pairing the first Bluetooth device].

### **i** Information

- Bluetooth® standby mode lasts for three minutes. If a device is not paired within three minutes, pairing is canceled. Start over from the beginning.
- For most Bluetooth® devices, a connection is established automatically after pairing. Some devices, however, require separate confirmation when connecting after pairing. Be sure to check your Bluetooth® device after pairing to confirm that it has connected.

### Connecting Bluetooth® devices

#### If there are no connected devices

Press the **[PHONE]** button on the audio system or the **[CALL]** button in the steering wheel remote control → List of paired Bluetooth® devices → Select the desired Bluetooth® device from the list → Connect Bluetooth®.

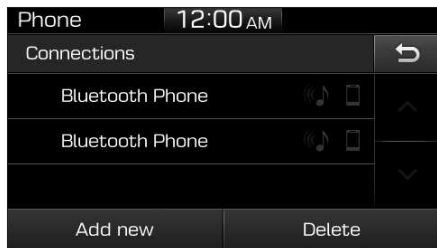

#### If there are connected devices

Press the **[PHONE]** button on the audio system → Select **[Settings]** → Select **[Connections]** → Select Bluetooth® device to connect → Select **[Connect]** → Connect Bluetooth®.

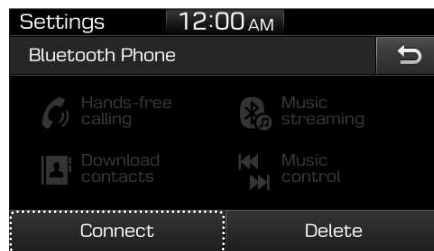

### **i** Information

- Only one Bluetooth® device can be connected at a time.
- When a Bluetooth® device is connected, other devices cannot be paired.

### Accepting/rejecting phone calls

Receiving phone calls with Bluetooth® connected.



- (1) Caller name: If the caller number is in your contacts, the corresponding name is displayed.
- (2) Incoming phone number: Incoming phone number is displayed.
- (3) Accept: Accept call.
- (4) Reject: Reject call.

### **i** Information

- When the incoming call screen is displayed, audio mode and the settings screen cannot be shown. Only call volume control is supported.
- Some Bluetooth® devices may not support the call reject function.
- Some Bluetooth® devices may not support the phone number display function.

### **Operation during calls**

Incoming call with Bluetooth® connected → Select [Accept].

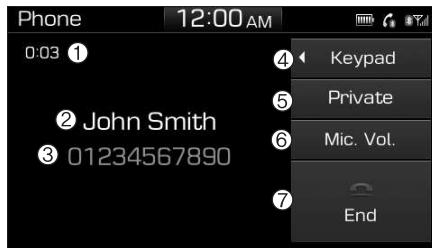

- (1) Call duration: Call duration display.
- (2) Caller name: If the caller number is in your contacts, the corresponding name is displayed.
- (3) Incoming phone number: Incoming phone number is displayed.
- (4) Keypad: Number keypad for Automatic Response Service input is displayed.
- (5) Private: Call is transferred to a cell phone.
- (6) Microphone Volume: Adjust outgoing voice volume.
- (7) End: End call.

### **i** Information

- Some Bluetooth® devices may not support the Private function.
- The outgoing voice volume may vary depending on the type of Bluetooth® device. If the outgoing voice volume is too high or low, adjust the Microphone Volume.

### **Favourites**

Press the [PHONE] button on the audio system → Select [Favourites] → Favourites list displayed.



- (1) Favourites list: A list of paired favourites is displayed. Connect a call when selected.

- (2) Add to favourites: Add a downloaded phone number to favourites.
- (3) Delete: Delete a saved favourites.

### **i** Information

- Up to 20 favourites can be saved for each connected Bluetooth® device.
- Favourites can be accessed when the Bluetooth® device they were paired from is connected.
- The audio system does not download favourites from Bluetooth® devices. Favourites must be newly saved before use.
- To add to favourites, contacts must be downloaded first.
- Saved favourites are not updated even if the contacts of the connected Bluetooth® device are changed. In this case, favourites need to be deleted and added again.

### **Call history**

Press the **[PHONE]** button on the audio system → Select [Call history] → Call history is displayed.



- (1) Call history: Display the downloaded call history list.  
Connect a call when selected.
- (2) Sort by: Sort by all calls, dialled calls, received calls or missed calls.
- (3) Download: Download call history from connected Bluetooth® devices.

### **i** Information

- Up to 50 dialled, received and missed calls are saved.
- When the latest call history is received, the existing call history is deleted.

### **Contacts**

Press the **[PHONE]** button on the audio system → Select [Contacts] → Select letter (ABC) → Contacts displayed.



- (1) Contacts: Display downloaded contacts.  
Connect a call when selected.
- (2) Download: Download contacts from connected Bluetooth® devices.

## **i** Information

- Only supported contacts format can be downloaded and displayed from the Bluetooth device, contacts from some applications will not be included.
- Up to 2,000 contacts can be saved.
- In some cases, additional confirmation from your Bluetooth® device is necessary when downloading contacts. If downloading of contacts unsuccessful, consult your Bluetooth® device's settings or the audio screen to approve the download.
- Contacts without phone numbers are not displayed.

## **Dial**

Press the **[PHONE]** button on the audio system → Select [Dial].



- (1) Phone number entry window: The phone number entered using the keypad is displayed.
- (2) Clear
  - Select to delete individual digits.
  - Press and hold to delete the entire phone number.
- (3) Keypad: Enter phone number.
- (4) Bluetooth® Phone name
  - The name of the connected Bluetooth® device is displayed.
  - Contacts matching the keypad number/letter input are displayed.

## (5) Call

- Enter and select a phone number to call.
- Select without entering a phone number to see the most recent dialled call.

## **Settings**

Press the **[PHONE]** button on the audio system → Select [Settings].

- For more details, refer to Setup → Bluetooth page.

### Setup



Access Display, Sound, Date/Time, Bluetooth, System, Screensaver, Display Off and Drive mode settings. Press the **[SETUP]** button on the audio system.

#### **Display**

Press the **[SETUP]** button on the audio system → Select [Display].

- Dimming mode: Adjusts the brightness automatically according to surrounding brightness.
- Brightness: The brightness of the audio screen can be changed.

#### **Sound**

Press the **[SETUP]** button on the audio system → Select [Sound].

- Position: Sound balance and fader can be adjusted.
- Equaliser: Sound tone color can be adjusted.
- Rear parking sensors prioritised: Automatically lower audio volume while reversing.
- Speed dependent volume control: Automatically adjust volume based on vehicle speed.
- Beep: Select whether to play a beep sound when the screen is touched.

#### **Date/Time**

Press the **[SETUP]** button on the audio system → Select [Date/Time].

- Set time: Set the time displayed on the audio screen.
- Time format: Choose between 12-hour and 24-hour time formats.
- Set date: Set the date displayed on the audio screen.

#### **Bluetooth**

Press the **[SETUP]** button on the audio system → Select [Bluetooth].

- Connections: Control pairing, deletion, connection and disconnection of Bluetooth® devices.
- Auto connection priority: Set the connection priority of Bluetooth® devices when the vehicle is started.
- Update contacts: Contacts can be downloaded from connected Bluetooth® devices.
- Bluetooth voice guidance: Play or mute voice prompts for Bluetooth® device pairing, connection and errors.

### **i** Information

- When paired devices are deleted, the call history and contacts of the device saved to the audio system are deleted.
- For Bluetooth® connections with low connection priority, some time may be required for the connection to be established.
- Contacts can be downloaded only from the currently connected Bluetooth® device.
- If no Bluetooth® device is connected, the Download Contacts button is disabled.
- If the language setting is Slovakian or Hungarian, Bluetooth voice guidance is not supported.

### **System**

Press the [SETUP] button on the audio system → Select [System].

- Memory information: View My Music memory usage.
- Language: Change the user language.
- Default: Reset the audio system.

### **i** Information

The system resets to the default values, and all saved data and settings are lost.

### **Screensaver**

Set the information displayed when the audio system is switched off or the screen is turned off.

Press the [SETUP] button on the audio system → Select [Screensaver].

- Analogue: An analog clock is displayed.
- Digital: A digital clock is displayed.
- None: No information is displayed.

### **Display Off**

To prevent glare, the screen can be turned off with the audio system in operation.

Press the [SETUP] button on the audio system → Select [Display Off].

### **i** Information

Use ‘Screensaver’ to set the information to be displayed when the screen is turned off.

### **Drive Mode**

Sets Drive Mode detailed settings for each vehicle control unit and notification settings for Mode changes.

Press the [SETUP] button on the audio system → Select [Drive mode].

### **i** Information

The options provided in the Vehicle Settings may vary by the vehicle model.

# Declaration of Conformity

## CE for EU

### Declaration of Conformity

We, manufacturer, hereby declare that the product

Model: ACBC2G4EE, ACB00G3GG, ACB10G3GG, ACB01G3GG, ACB11G3GG, ACB00G3BN,  
ACB10G3BN, ACB00G3GE, ACB10G3GE, ACB00G3GL, ACB10G3GL, ACB12G4RE, ACB11G4EG,  
ACB11G4EN, ACB13G4EE, ACB11G4EE, ACB13G4EG, ACB10G3MG, ACB00G3MG, ACB10S0EE,  
ACB13S0EE, ACBC0S0EE, ACBC1S0EE, ACB10S0EG, ACB11S0EG, ACB10S0EN, ACB11S0EE,  
ACB14S0EE, ACB10S0GL, ACB11S0GL, ACB10S0UG, ACB11S0UG  
Type: DIGITAL CAR AUDIO SYSTEM

satisfies all the technical regulations applicable to the product within the scope of Council Directives 2006/95/EC, 2004/108/EC and 99/5/EC:

Radio: EN 300 328 V.1.9.1(2015-02) \_\_\_\_\_  
EMC: EN 55013 : 2013 \_\_\_\_\_  
EN 55020 : 2007 / A11 : 2011 \_\_\_\_\_  
ETSI EN 301 488-1 V.1.9.2 \_\_\_\_\_  
ETSI EN 301 489-17 V.2.2.1 \_\_\_\_\_  
Safety: EN 60965:2014 \_\_\_\_\_

All essential radio test suites have been carried out.

Testing laboratory: DT&C Co., Ltd.

42 Yurim-ro, 154beon-gil, Cheoin-gu, Yongin-si, Gyeonggi-do, Korea, 449-935  
Tel. +82 31 321 2664 / Fax. +82 31 321 1664

Authorized representative or manufacturer:

HYUNDAI MOBIS Co., Ltd.  
203 Teheran-ro, Gangnam-gu, Seoul, 135-977, Korea  
Tel. 82-31-260-0098 / Fax. 82-31-899-1788

This declaration is issued under the sole responsibility of the manufacturer and, if applicable, his authorized Representative, and is marked in accordance with the CE marking directive 93/68/EEC.

Point of contact :

HYUNDAI MOBIS Co., Ltd. Tel. 82-31-260-0098 / Fax. 82-31-899-1788

Seoul, Korea Feb. 27, 2017



최승훈

/ S. H. Choe  
/ Director



## Driving your vehicle

<b>Before driving</b> .....	5-4	<b>Electronic limited slip differential</b> .....	5-38
Before entering the vehicle .....	5-4	Warning messages .....	5-39
Before starting.....	5-4	<b>Drive Mode integrated control system</b> .....	5-40
<b>Ignition switch</b> .....	5-6	DRIVE MODE button.....	5-40
Key ignition switch.....	5-6	P button.....	5-41
Engine Start/Stop button.....	5-9	Vehicle characteristic .....	5-43
<b>Manual transmission</b> .....	5-14	<b>ISG (Idle Stop and Go) system</b> .....	5-44
Manual transmission operation .....	5-14	To activate the ISG system.....	5-44
Rev matching.....	5-17	To deactivate the ISG system .....	5-47
<b>Launch control</b> .....	5-21	ISG system malfunction.....	5-47
Prerequisite for activation .....	5-21	The battery sensor deactivation .....	5-48
Launch control activation .....	5-21	<b>Autonomous Emergency Braking (AEB)</b>	
<b>Braking system</b> .....	5-23	- <b>Camera Type</b> .....	5-49
Power brakes .....	5-23	System setting and activation.....	5-49
Disc brakes wear indicator .....	5-24	AEB warning message and system control.....	5-51
High performance brake .....	5-24	AEB sensor .....	5-53
Parking brake .....	5-25	Warning message and warning light.....	5-54
Anti-lock Brake System (ABS) .....	5-26	Limitations of the system .....	5-56
Electronic Stability Control (ESC).....	5-28	<b>Speed Limit Information Function (SLIF)</b> .....	5-60
Vehicle Stability Management.....	5-33	System setting and activation.....	5-61
Hill-Start Assist Control (HAC) .....	5-35	Display.....	5-61
Emergency Stop Signal (ESS) .....	5-35	Warning message .....	5-62
Good braking practices.....	5-36	Limitations of the system .....	5-63
<b>Electronic control suspension (ECS)</b> .....	5-37		

<b>Lane Keeping Assist System (LKAS)</b> .....	5-64
LKAS operation.....	5-66
Warning light and message.....	5-69
Limitations of the system.....	5-71
LKAS function change.....	5-72
<b>Lane Departure Warning System (LDWS)</b> .....	5-73
LDWS operation.....	5-74
Warning light and message.....	5-75
Limitations of the system.....	5-76
<b>Driver Attention Alert system (DAA)</b> .....	5-78
System setting and activation.....	5-78
Resetting the system.....	5-79
System standby.....	5-80
System malfunction.....	5-80
<b>Cruise control</b> .....	5-82
Cruise Control operation.....	5-82
<b>Special driving conditions</b> .....	5-88
Hazardous driving conditions.....	5-88
Rocking the vehicle.....	5-88
Smooth cornering.....	5-89
Driving at night.....	5-89
Driving in the rain.....	5-89
Driving in flooded areas.....	5-90
Highway driving.....	5-90
<b>Winter driving</b> .....	5-91
Snow or icy conditions.....	5-91
Winter Precautions.....	5-94
<b>Trailer towing (for europe)</b> .....	5-96
If you decide to pull a trailer?.....	5-97
Trailer towing equipment.....	5-99
Driving with a trailer.....	5-100
Maintenance when towing a trailer.....	5-103
<b>Vehicle weight</b> .....	5-105
Overloading.....	5-105

## WARNING

### **Carbon monoxide (CO) gas is toxic. Breathing CO can cause unconsciousness and death.**

Engine exhaust contains carbon monoxide which cannot be seen or smelled.

#### **Do not inhale engine exhaust.**

If at any time you smell engine exhaust inside the vehicle, open the windows immediately. Exposure to CO can cause unconsciousness and death by asphyxiation.

#### **Be sure the exhaust system does not leak.**

The exhaust system should be checked whenever the vehicle is raised to change the oil or for any other purpose. If you hear a change in the sound of the exhaust or if you drive over something that strikes the underneath side of the vehicle, we recommend that the exhaust system be checked as soon as possible by an authorized HYUNDAI dealer.

#### **Do not run the engine in an enclosed area.**

Letting the engine idle in your garage, even with the garage door open, is a hazardous practice. Run the engine only long enough to start the engine and to move the vehicle out of the garage.

#### **Avoid idling the engine for prolonged periods with people inside the vehicle.**

If it is necessary to idle the engine for a prolonged period with people inside the vehicle, be sure to do so only in an open area with the air intake set at "Fresh" and fan control set to high so fresh air is drawn into the interior.

#### **Keep the air intakes clear.**

To assure proper operation of the ventilation system, keep the ventilation air intakes located in front of the windshield clear of snow, ice, leaves, or other obstructions.

#### **If you must drive with the tailgate open:**

Close all windows.

Open instrument panel air vents.

Set the air intake control at "Fresh", the air flow control at "Floor" or "Face", and the fan control set to high.

### BEFORE DRIVING

#### Before entering the vehicle

- Be sure all windows, outside mirror(s), and outside lights are clean and unobstructed.
- Remove frost, snow, or ice.
- Visually check the tires for uneven wear and damage.
- Check under the vehicle for any sign of leaks.
- Be sure there are no obstacles behind you if you intend to back up.

#### Before starting

- Make sure the hood, the tailgate, and the doors are securely closed and locked.
- Adjust the position of the seat and steering wheel.
- Adjust the inside and outside rearview mirrors.
- Verify all the lights work.
- Fasten your seat belt. Check that all passengers have fastened their seat belt.
- Check the gauges and indicators in the instrument panel and the messages on the instrument display when the ignition switch is in the ON position.
- Check that any items you are carrying are stored properly or fastened down securely.

#### WARNING

**To reduce the risk of SERIOUS INJURY or DEATH, take the following precautions:**

- **ALWAYS wear your seat belt. All passengers must be properly belted whenever the vehicle is moving. For more details, refer to "Seat Belts" in chapter 2.**
- **Always drive defensively. Assume other drivers or pedestrians may be careless and make mistakes.**
- **Stay focused on the task of driving. Driver distraction can cause accidents.**
- **Leave plenty of space between you and the vehicle in front of you.**

 **WARNING**

**NEVER** drink or take drugs and drive.

Drinking or taking drugs and driving is dangerous and may result in an accident and **SERIOUS INJURY** or **DEATH**.

Drunk driving is the number one contributor to the highway death toll each year. Even a small amount of alcohol will affect your reflexes, perceptions and judgment. Just one drink can reduce your ability to respond to changing conditions and emergencies and your reaction time gets worse with each additional drink.

Driving while under the influence of drugs is as dangerous or more dangerous than driving under the influence of alcohol.

(Continued)

(Continued)

You are much more likely to have a serious accident if you drink or take drugs and drive. If you are drinking or taking drugs, don't drive. Do not ride with a driver who has been drinking or taking drugs. Choose a designated driver or call a taxi.

## IGNITION SWITCH

### WARNING

To reduce the risk of **SERIOUS INJURY** or **DEATH**, take the following precautions:

- **NEVER** allow children or any person who is unfamiliar with the vehicle to touch the ignition switch or related parts. Unexpected and sudden vehicle movement can occur.
- **NEVER** reach through the steering wheel for the ignition switch, or any other control, while the vehicle is in motion. The presence of your hand or arm in this area may cause a loss of vehicle control resulting in an accident.

### Key ignition switch (if equipped)

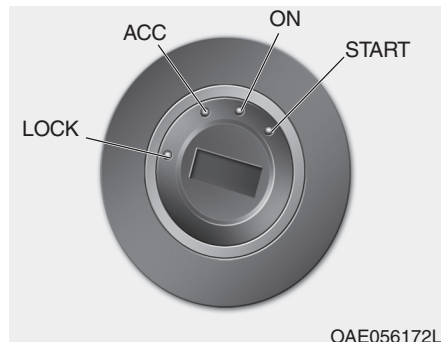

Whenever the front door is opened, the ignition switch will illuminate, provided the ignition switch is not in the ON position. The light will go off immediately when the ignition switch is turned on or go off after about 30 seconds when the door is closed. (if equipped)

### WARNING

- **NEVER** turn the ignition switch to the **LOCK** or **ACC** position while the vehicle is in motion except in an emergency.

(Continued)

(Continued)

This will result in the engine turning off and loss of power assist for the steering and brake systems. This may lead to loss of directional control and braking function, which could cause an accident.

- Before leaving the driver's seat, always make sure the shift lever is in 1st gear when the vehicle is parked on a uphill and in R (Reverse) on a downhill, apply the parking brake, and turn the ignition switch to the **LOCK** position.

Unexpected vehicle movement may occur if these precautions are not followed.

### NOTICE

Never use aftermarket keyhole covers. This may generate start-up failure due to communication failure.

### **Key ignition switch positions**

<b>Switch Position</b>	<b>Action</b>	<b>Notes</b>
<b>LOCK</b>	To turn the ignition switch to the LOCK position, push the key in at the ACC position and turn the key towards the LOCK position. The ignition key can be removed in the LOCK position. The steering wheel locks to protect the vehicle from theft. (if equipped)	
<b>ACC</b>	Some electrical accessories are usable. The steering wheel unlocks.	If difficulty is experienced turning the ignition switch to the ACC position, turn the key while turning the steering wheel right and left to release.
<b>ON</b>	This is the normal key position when the engine has started. All features and accessories are usable. The warning lights can be checked when you turn the ignition switch from ACC to ON.	Do not leave the ignition switch in the ON position when the engine is not running to prevent the battery from discharging.
<b>START</b>	To start the engine, turn the ignition switch to the START position. The switch returns to the ON position when you let go of the key.	The engine will crank until you release the key.

### Starting the engine

#### WARNING

- Always wear appropriate shoes when operating your vehicle. Unsuitable shoes, such as high heels, ski boots, sandals, flip-flops, etc., may interfere with your ability to use the brake, accelerator and clutch pedals.
- Do not start the vehicle with the accelerator pedal depressed. The vehicle can move which can lead to an accident.
- Wait until the engine rpm is normal. The vehicle may suddenly move if the brake pedal is released when the rpm is high.

1. Make sure the parking brake is applied.
2. Make sure the shift lever is in neutral.
3. Depress the clutch and brake pedals.
4. Turn the ignition switch to the START position. Hold the key (maximum of 10 seconds) until the engine starts and release it.

#### Information

- Do not wait for the engine to warm up while the vehicle remains stationary. Start driving at moderate engine speeds. (Steep accelerating and decelerating should be avoided.)
- Always start the vehicle with your foot on the brake pedal. Do not depress the accelerator while starting the vehicle. Do not race the engine while warming it up.

#### NOTICE

#### To prevent damage to the vehicle:

- Do not hold the ignition key in the START position for more than 10 seconds. Wait 5 to 10 seconds before trying again.
- Do not turn the ignition switch to the START position with the engine running. It may damage the starter.
- If traffic and road conditions permit, you may put the shift lever in the N (Neutral) position while the vehicle is still moving and turn the ignition switch to the START position in an attempt to restart the engine.
- Do not push or tow your vehicle to start the engine.

#### Turning off the engine

1. Stop the vehicle and depress the clutch and brake pedals at the same time.
2. With the clutch and brake pedals depressed, put the shift lever in neutral.
3. Turn off the engine and apply the parking brake.



## Engine Start/Stop button (if equipped)



OPD056001

Whenever the front door is opened, the Engine Start/Stop button will illuminate and will go off 30 seconds after the door is closed.

### WARNING

To turn the engine off in an emergency:



Press and hold the Engine Start/Stop button for more than two seconds OR Rapidly press and release the Engine Start/Stop button three times (within three seconds).



If the vehicle is still moving, you can restart the engine without depressing the brake pedal by pressing the Engine Start/Stop button with the shift lever in the N (Neutral) position.

### WARNING

- NEVER press the Engine Start/Stop button while the vehicle is in motion except in an emergency. This will result in the engine turning off and loss of power assist for the steering and brake systems. This may lead to loss of directional control and braking function, which could cause an accident.
- Before leaving the driver's seat, always make sure the shift lever is in 1st gear when the vehicle is parked on an uphill and in R (Reverse) on a downhill, set the parking brake, press the Engine Start/Stop button to the OFF position, and take the Smart Key with you. Unexpected vehicle movement may occur if these precautions are not followed.

### Engine Stop/Start button positions

Button Position	Action	Notes
<b>OFF</b> 	To turn off the engine, stop the vehicle and then press the Engine Start/Stop button. The steering wheel locks to protect the vehicle from theft. (if equipped)	If the steering wheel is not locked properly when you open the driver's door, the warning chime will sound.
<b>ACC</b> 	Press the Engine Start/Stop button when the button is in the OFF position without depressing the clutch pedal. Some electrical accessories are usable. The steering wheel unlocks.	If you leave the Engine Start/Stop button in the ACC position for more than one hour, the battery power will turn off automatically to prevent the battery from discharging. If the steering wheel doesn't unlock properly, the Engine Start/Stop button will not work. Press the Engine Start/Stop button while turning the steering wheel right and left to release.

Button Position	Action	Notes
<p data-bbox="254 250 299 274"><b>ON</b></p> 	<p data-bbox="416 257 925 341">Press the Engine Start/Stop button while it is in the ACC position without depressing the clutch pedal.</p> <p data-bbox="416 351 911 406">The warning lights can be checked before the engine is started.</p>	<p data-bbox="959 257 1485 341">Do not leave the Engine Start/Stop button in the ON position when the engine is not running to prevent the battery from discharging.</p>
<p data-bbox="232 556 320 580"><b>START</b></p> 	<p data-bbox="416 563 925 647">To start the engine, depress the clutch and brake pedals and press the Engine Start/Stop button with the shift lever in neutral.</p>	<p data-bbox="959 563 1442 676">If you press the Engine Start/Stop button without depressing the clutch pedal, the engine does not start and the Engine Start/Stop button changes as follows:</p> <p data-bbox="959 683 1389 712"><b>OFF → ACC → ON → OFF or ACC</b></p>

### Starting the engine

#### WARNING

- Always wear appropriate shoes when operating your vehicle. Unsuitable shoes, such as high heels, ski boots, sandals, flip-flops, etc., may interfere with your ability to use the brake, accelerator and clutch pedals.
- Do not start the vehicle with the accelerator pedal depressed. The vehicle can move which can lead to an accident.
- Wait until the engine rpm is normal. The vehicle may suddenly move if the brake pedal is released when the rpm is high.

#### Information

- The engine will start by pressing the Engine Start/Stop button, only when the smart key is in the vehicle.
- Even if the smart key is in the vehicle, if it is far away from the driver, the engine may not start.
- When the Engine Start/Stop button is in the ACC or ON position, if any door is open, the system checks for the smart key. If the smart key is not in the vehicle, the "🚗" indicator will blink and the warning "Key not in vehicle" will come on, and if all doors are closed, the chime will also sound for about 5 seconds. Keep the smart key in the vehicle when using the ACC position or if the vehicle engine is ON.

1. Always carry the smart key with you.
2. Make sure the parking brake is applied.
3. Make sure the shift lever is in neutral.
4. Depress the clutch and brake pedals.
5. Press the Engine Start/Stop button.

#### Information

- Do not wait for the engine to warm up while the vehicle remains stationary. Start driving at moderate engine speeds. Steep accelerating and decelerating should be avoided.
- Always start the vehicle with your foot on the brake pedal. Do not depress the accelerator while starting the vehicle. Do not race the engine while warming it up.

#### NOTICE

To prevent damage to the vehicle:

- If traffic and road conditions permit, you may put the shift lever in the N (Neutral) position while the vehicle is still moving and press the Engine Start/Stop button in an attempt to restart the engine.
- Do not push or tow your vehicle to start the engine.

## NOTICE

To prevent damage to the vehicle: Do not press the Engine Start/Stop button for more than 10 seconds except when the stop lamp fuse is blown.

When the stop lamp fuse is blown, you can't start the engine normally. Replace the fuse with a new one. If you are not able to replace the fuse, you can start the engine by pressing and holding the Engine Start/Stop button for 10 seconds with the Engine Start/Stop button in the ACC position.

For your safety always depress the brake and/or clutch pedal before starting the engine.

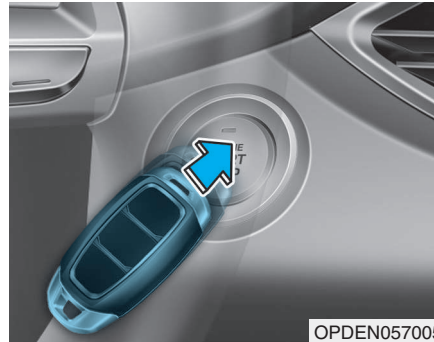

## **i** Information

If the smart key battery is weak or the smart key does not work correctly, you can start the engine by pressing the Engine Start/Stop button with the smart key in the direction of the picture above.

## **Turning off the engine**

1. Stop the vehicle and depress the clutch and brake pedals at the same time.
2. With the clutch and brake pedals depressed, put the shift lever in neutral.
3. Press the Engine Start/Stop button to the off position and apply the parking brake.

## MANUAL TRANSMISSION

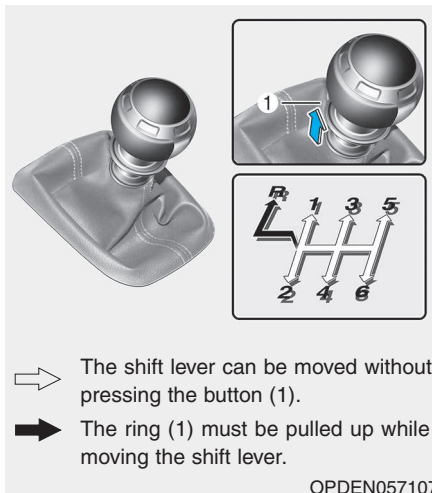

### Manual transmission operation

The manual transmission has 6 forward gears. The transmission is fully synchronized in all forward gears so shifting to either a higher or a lower gear is easily accomplished.

#### WARNING

**Before leaving the driver's seat, always make sure the shift lever is in 1st gear when the vehicle is parked on a uphill and in R (Reverse) on a downhill, set the parking brake, and place the ignition switch in the LOCK/OFF position. Unexpected vehicle movement may occur if these precautions are not followed.**

To shift to R (Reverse), make sure the vehicle has completely stopped, and then move the shift lever to neutral before moving into R (Reverse).

When you've come to a complete stop and it's hard to shift into 1st gear or R (Reverse):

1. Put the shift lever in neutral and release the clutch pedal.
2. Depress the clutch pedal, and then shift into first or R (Reverse) gear.

#### Information

During cold weather, shifting may be difficult until the transmission lubricant has warmed up.

### **Using the clutch**

The clutch pedal should be depressed all the way to the floor before:

- Starting the engine

The engine will not start without depressing the clutch pedal.

- Shifting into gear, up shifting to the next higher gear, or down shifting to the next lower gear.

When releasing the clutch pedal, release it slowly. The clutch pedal should always be released while driving.



#### **CAUTION**

**To start or reverse the vehicle, release the clutch pedal slowly after shifting the gear. Sudden release of the clutch pedal may result in an abrupt accident.**

#### **NOTICE**

**To prevent unnecessary wear or damage to the clutch:**

- **Do not rest your foot on the clutch pedal while driving.**
- **Do not hold the vehicle with the clutch on an incline, while waiting for the traffic light, etc.**
- **Always depress the clutch pedal down fully to prevent noise or damage.**
- **Do not repeatedly depress the clutch pedal before the clutch pedal returns back to its original place when released.**
- **Do not start with the 2nd (second) gear engaged except when you start on a slippery road.**
- **Do not drive with cargo loaded more than required loading capacity.**

### **Downshifting**

Downshift when you must slow down in heavy traffic or drive up a steep hill, to prevent engine load.

Also, downshifting reduces the chance of stalling and helps to accelerate when you need to increase your speed again.

When the vehicle is going downhill, downshifting helps maintain safe speed by providing brake power from the engine and results in less wear on the brakes.

### NOTICE

To prevent damage to the engine, clutch and transmission:

- When downshifting from 5th gear to 4th gear, be careful not to inadvertently push the shift lever sideways engaging the 2nd gear. A drastic downshift may cause the engine speed to increase to the point the tachometer will enter the red-zone.
- Do not downshift more than two gears at a time or downshift the gear when the engine is running at high speed (5,000 RPM or higher). Such a downshifting may damage the engine, clutch and the transmission.

### Good driving practices

- Never take the vehicle out of gear and coast down a hill. This is extremely dangerous.
- Don't "ride" the brakes. This can cause the brakes and related parts to overheat and malfunction.

When you are driving down a long hill, slow down and shift to a lower gear. Engine braking will help slow down the vehicle.

- Slow down before shifting to a lower gear. This will help avoid over-revving the engine, which can cause damage.
- Slow down when you encounter cross winds. This gives you much better control of your vehicle.
- Be sure the vehicle is completely stopped before you shift into R (Reverse) to prevent damage to the transmission.

- Exercise extreme caution when driving on a slippery surface. Be especially careful when braking, accelerating or shifting gears. On a slippery surface, an abrupt change in vehicle speed can cause the drive wheels to lose traction and may cause loss of vehicle control resulting in an accident.

### WARNING

**Do not use aggressive engine braking (shifting from a higher gear to a lower gear) on slippery roads. This could cause the tires to slip and may result in an accident.**



## WARNING

To reduce the risk of **SERIOUS INJURY** or **DEATH**:

- **ALWAYS** wear your seat belt. In a collision, an unbelted occupant is significantly more likely to be seriously injured or killed than a properly belted occupant.
- Avoid high speeds when cornering or turning.
- Do not make quick steering wheel movements, such as sharp lane changes or fast, sharp turns.
- The risk of rollover is greatly increased if you lose control of your vehicle at highway speeds.
- Loss of control often occurs if two or more wheels drop off the roadway and the driver over steers to reenter the roadway.

(Continued)

(Continued)

- In the event your vehicle leaves the roadway, do not steer sharply. Instead, slow down before pulling back into the travel lanes.
- **HYUNDAI** recommends you follow all posted speed limits.

## Rev matching

The Rev Matching system automatically helps synchronize engine rpm with the optimal speed of the gear about to be engaged which reduces the impact of clutch connection and improves gear shift response.

### Information

- Fully depress the clutch pedal. Without the clutch pedal fully depressed, the system may not response correctly.
- The system does not operate when backing up.
- Rev Matching controls the engine speed up to the rev limit, but the function cannot prevent over-revving caused by shifting mistake.

### Rev Matching activation

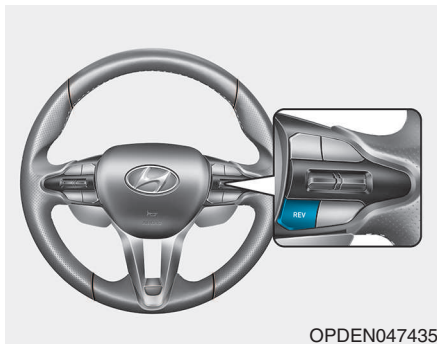

#### 1. Press REV button (ON/OFF)

- Press the REV button to turn on the system. A message appears "Rev Matching On" with a REV indicator on the cluster LCD display.
- Press the REV button again to turn off the system. A message appears "Rev Matching Off" and the REV indicator disappears.

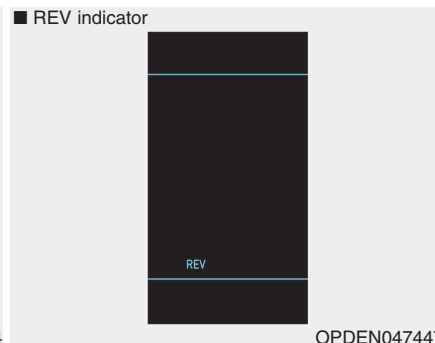
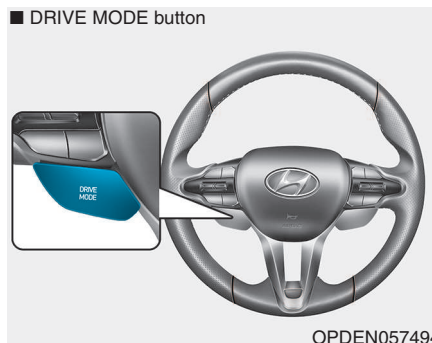

#### 2. Select Drive Mode.

##### DRIVE MODE button

Use Rev Matching in normal driving conditions in below modes.

- When ECO mode is selected:
  - Rev Matching cannot be activated even if the driver presses the REV button.
  - REV indicator is off.
- When NORMAL mode is selected:
  - Rev Matching activates if Rev Matching is turned on by the REV button.
  - White REV indicator illuminates.
  - Engine rpm response during gear shift is smooth.
- When SPORT mode is selected:
  - Rev Matching activates if Rev Matching is turned on by the REV button.
  - Yellow REV indicator illuminates.
  - Engine rpm response is faster than NORMAL mode.

The system must be turned on by pressing the REV button whenever the engine is turned on.

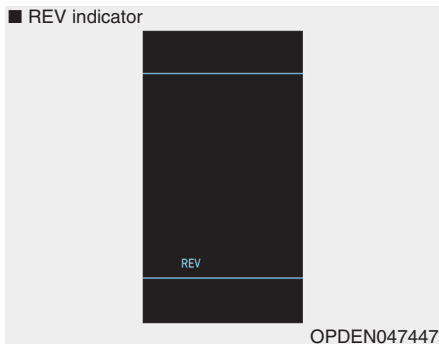
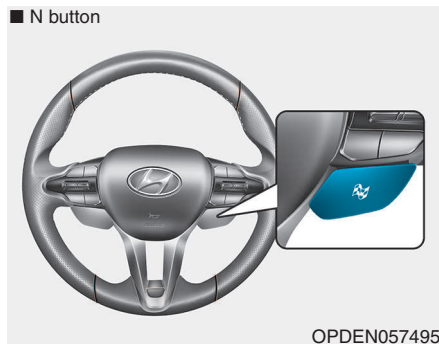

### N button

Use Rev Matching when driving on race tracks, etc. in N mode.

- When N mode (SPORT+) is selected:
  - REV Matching is turned on automatically. To turn off Rev Matching, press the REV button.
  - Red REV indicator illuminates.
  - Engine speed is automatically adjusted to the shifted gear without the accelerator pedal depressed.
  - Engine rpm response is faster than SPORT mode when downshifting with heavy braking such as when driving on a race track.
- When CUSTOM mode is selected:
  - You may select the drive mode you prefer from the Audio or AVN screen Custom setting page. (OFF/NORMAL/SPORT/SPORT+).

**For more details on "Custom Mode" refer to the Audio manual in chapter 4 or the separately supplied Multimedia manual.**

### Rev Matching operation

Engine speed is automatically synchronized with the next selected gear. The accelerator pedal does not have to be depressed to speed up the engine rpm.

- Clutch depressed with the gear engaged

At once, engine speed automatically decreases right after the clutch is disengaged, but the selected gear is fixed and then the engine rpm reverts to the selected gear's target speed. This operation method gives more comfortable feeling in public road driving.

- Upshifting

Engine speed will automatically decrease and stay at the target engine speed before the clutch is engaged.

- Downshifting

Engine speed will automatically increase and stay at the target engine speed.

### **Warning message**

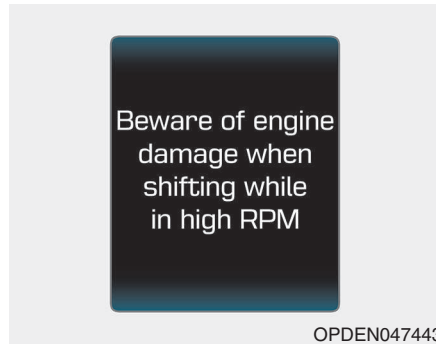

#### **Beware of engine damage when shifting while in high RPM**

If transmission input rpm is too high (over rev limit) due to shifting, a warning message will appear and a warning chime will sound.

## LAUNCH CONTROL

The Launch Control system controls the vehicle to reduce wheel spin or slip on a hard acceleration from a standing start.

### Prerequisite for activation

The Launch Control gets ready to be activated, when the following prerequisites are satisfied.

- The engine is warmed up.
- The driver's seatbelt is fastened.
- All doors, hood and tailgate is closed.
- The vehicle is at a complete stop.
- Malfunction warning lights related to the engine and ESC (Electronic Stability Control) is off.

### Launch control activation

To activate Launch Control:

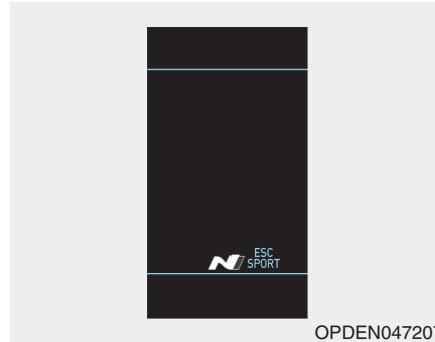

1. Select N mode.
2. Check if ESC SPORT mode is turned on. If not, set ESC mode to ESC SPORT mode.
3. Depress the clutch pedal.
4. Shift the transmission to 1st gear.
5. Align the steering wheel straight.

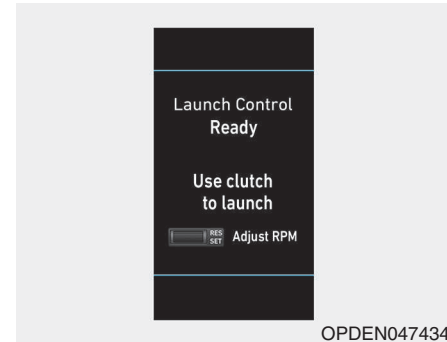

6. Fully depress the accelerator pedal. The Launch Control system will initially limit engine speed as the driver fully applies the accelerator pedal. Allow the engine rpm to stabilize.

The message "Launch Control Ready. Use clutch to launch" and "Adjust RPM" will appear on the cluster LCD display. If necessary, adjust engine rpm with the cruise control switch (+/-).

7. A smooth, quick release of the clutch, while maintaining full depression of the accelerator pedal will initiate launching of the vehicle. Do not rapidly drop the clutch pedal as it may damage clutch related parts and will not result in optimal launching performance.

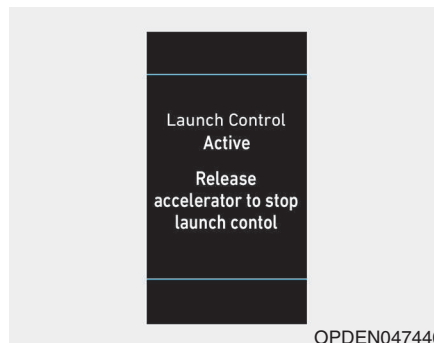

8. During vehicle launching, continue to depress the accelerator pedal to keep the Launch Control system active until desired duration.

The message "Launch Control Active" and "Release accelerator to stop launch control" will appear on the cluster LCD display.

To deactivate (end) Launch Control, release the accelerator pedal or depress clutch pedal.

### **i** Information

Launch Control is available again after cooling down by driving the vehicle for at least 3 minutes.

### **⚠ CAUTION**

- The Launch Control system is intended for use at a closed race track and not intended for use on public roads. It will not compensate for driver's who are inexperienced or lack familiarity with the race track.
- Do not use Launch Control during break-in period of the vehicle.

### **NOTICE**

Constant use of Launch Control can put enormous stress on the vehicle resulting in premature wear of related components.

### **NOTICE**

In a manual transmission vehicle, the Launch Control system's performance heavily depends on clutch contact maneuver, tire grip level and road surface conditions. The system does not always guarantee best launching performance of the vehicle.

## BRAKING SYSTEM

### Power brakes

Your vehicle has power-assisted brakes that adjust automatically through normal usage.

If the engine is not running or is turned off while driving, the power assist for the brakes will not work. You can still stop your vehicle by applying greater force to the brake pedal than typical. The stopping distance, however, will be longer than with power brakes.

When the engine is not running, the reserve brake power is partially depleted each time the brake pedal is applied. Do not pump the brake pedal when the power assist has been interrupted.

Pump the brake pedal only when necessary to maintain steering control on slippery surfaces.

### WARNING

Take the following precautions:

- **Do not drive with your foot resting on the brake pedal. This will create abnormal high brake temperatures, excessive brake lining and pad wear, and increased stopping distances.**
- **When descending a long or steep hill, shift to a lower gear and avoid continuous application of the brakes. Applying the brakes continuously will cause the brakes to overheat and could result in a temporary loss of braking performance.**

(Continued)

(Continued)

- **Wet brakes may impair the vehicle's ability to safely slow down; the vehicle may also pull to one side when the brakes are applied. Applying the brakes lightly will indicate whether they have been affected in this way. Always test your brakes in this fashion after driving through deep water. To dry the brakes, lightly tap the brake pedal to heat up the brakes while maintaining a safe forward speed until brake performance returns to normal. Avoid driving at high speeds until the brakes function correctly.**

### Disc brakes wear indicator

When your brake pads are worn and new pads are required, you will hear a high pitched warning sound from your front or rear brakes. You may hear this sound come and go or it may occur whenever you depress the brake pedal.

Note that some driving conditions or climates may cause a brake squeal when you first apply (or lightly apply) the brakes. This is normal and does not indicate a problem with your brakes.

#### **NOTICE**

To avoid costly brake repairs, do not continue to drive with worn brake pads.

#### **i** Information

Always replace brake pads as complete front or rear axle sets.

### High performance brake

For vehicles equipped with the High Performance Brake (applied with material having high coefficient of friction), noise such as a squeal, squeak or groan is generated while braking. This is normal and the friction may create circle patterns on the disc surface. This is also a normal situation which does not affect braking performance.

#### **NOTICE**

- Occasional brake noise is normal. If a continuous grinding or continuous squeal sound is present, the brake lining may be worn-out. We recommend that the vehicle be checked by an authorized HYUNDAI dealer.
- If the vehicle has continuous vibration or shudder in the steering wheel while braking, we recommend that the vehicle be checked by an authorized HYUNDAI dealer.

#### **⚠ WARNING**

**Frequent speeding and braking may deform components and worn the disc brake causing vibration when braking. Prevent brake damage by avoiding excessive braking.**

**Brake wear, noise, vibration from excessive braking or deformation of the brakes caused by repeatedly braking in high speed, racing on tracks, etc. can be excluded from warranty coverage.**



## Parking brake

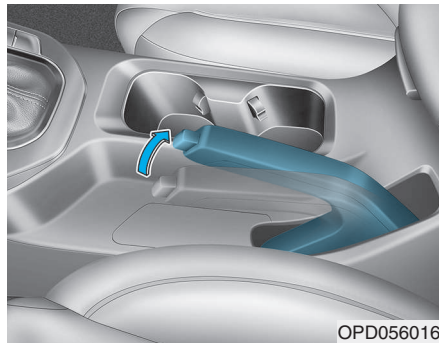

Always set the parking brake before leaving the vehicle, to apply:

Firmly depress the brake pedal.

Pull up the parking brake lever as far as possible.

### WARNING

To reduce the risk of **SERIOUS INJURY** or **DEATH**, do not operate the parking brake while the vehicle is moving except in an emergency situation. It could damage the brake system and lead to an accident.

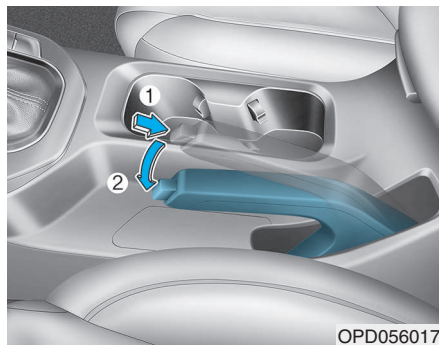

To release:

Firmly depress the brake pedal.

Slightly pull up the parking brake lever.

While pressing the release button (1), lower the parking brake (2).

If the parking brake does not release or does not release all the way, we recommend that the system be checked by an authorized HYUNDAI dealer.

### WARNING

- Whenever leaving the vehicle or parking, always come to a complete stop and continue to depress the brake pedal. Move the shift lever into 1st gear when the vehicle is parked on a uphill and in R (Reverse) on a downhill, then apply the parking brake, and place the ignition switch in the LOCK/OFF position.

Vehicles with the parking brake not fully engaged are at risk for moving inadvertently and causing injury to yourself or others.

- When parking on an incline, block the wheels to prevent the vehicle from rolling down.
- **NEVER** allow anyone who is unfamiliar with the vehicle to touch the parking brake. If the parking brake is released unintentionally, serious injury may occur.

(Continued)

(Continued)

- **Only release the parking brake when you are seated inside the vehicle with your foot firmly on the brake pedal.**

### NOTICE

- **Do not apply the accelerator pedal while the parking brake is engaged. If you depress the accelerator pedal with the parking brake engaged, a warning will sound. Damage to the parking brake may occur.**
- **Driving with the parking brake on can overheat the braking system and cause premature wear or damage to brake parts. Make sure the parking brake is released and the Brake Warning Light is off before driving.**



Check the Parking Brake Warning Light by placing the ignition switch to the ON position (do not start the engine).

This light will be illuminated when the parking brake is applied with the ignition switch in the START or ON position.

Before driving, be sure the parking brake is released and the Brake Warning Light is OFF.

If the Parking Brake Warning Light remains on after the parking brake is released while the engine is running, there may be a malfunction in the brake system. Immediate attention is necessary.

If at all possible, cease driving the vehicle immediately. If that is not possible, use extreme caution while operating the vehicle and only continue to drive the vehicle until you can reach a safe location.

## Anti-lock Brake System (ABS)

### ⚠ WARNING

**An Anti-Lock Braking System (ABS) or an Electronic Stability Control (ESC) system will not prevent accidents due to improper or dangerous driving maneuvers. Even though vehicle control is improved during emergency braking, always maintain a safe distance between you and objects ahead of you. Vehicle speeds should always be reduced during extreme road conditions. The braking distance for vehicles equipped with ABS or ESC may be longer than for those without these systems in the following road conditions.**

**Drive your vehicle at reduced speeds during the following conditions:**

- **Rough, gravel or snow-covered roads.**

(Continued)

(Continued)

- On roads where the road surface is pitted or has different surface height.
- Tire chains are installed on your vehicle.

**The safety features of an ABS or ESC equipped vehicle should not be tested by high speed driving or cornering. This could endanger the safety of yourself or others.**

ABS is an electronic braking system that helps prevent a braking skid. ABS allows the driver to steer and brake at the same time.

### **Using ABS**

To obtain the maximum benefit from your ABS in an emergency situation, do not attempt to modulate your brake pressure and do not try to pump your brakes. Depress your brake pedal as hard as possible.

When you apply your brakes under conditions which may lock the wheels, you may hear sounds from the brakes, or feel a corresponding sensation in the brake pedal. This is normal and it means your ABS is active.

ABS does not reduce the time or distance it takes to stop the vehicle.

Always maintain a safe distance from the vehicle in front of you.

ABS will not prevent a skid that results from sudden changes in direction, such as trying to take a corner too fast or making a sudden lane change. Always drive at a safe speed for the road and weather conditions.

ABS cannot prevent a loss of stability. Always steer moderately when braking hard. Severe or sharp steering wheel movement can still cause your vehicle to veer into oncoming traffic or off the road.

On loose or uneven road surfaces, operation of the anti-lock brake system may result in a longer stopping distance than for vehicles equipped with a conventional brake system.

The ABS warning light () will stay on for several seconds after the Ignition switch is placed in the ON position. During that time, the ABS will go through self-diagnosis and the light will go off if everything is normal. If the light stays on, you may have a problem with your ABS. We recommend that you contact an authorized HYUNDAI dealer as soon as possible.

 **WARNING**

If the ABS warning light () is on and stays on, you may have a problem with the ABS. Your power brakes will work normally. To reduce the risk of serious injury or death, we recommend that you contact your HYUNDAI dealer as soon as possible.

**NOTICE**

When you drive on a road having poor traction, such as an icy road, and apply your brakes continuously, the ABS will be active continuously and the ABS warning light () may illuminate. Pull your vehicle over to a safe place and turn the engine off.

Restart the engine. If the ABS warning light is off, then your ABS system is normal.

Otherwise, you may have a problem with your ABS system. We recommend that you contact an authorized HYUNDAI dealer as soon as possible.

 **Information**

When you jump start your vehicle because of a drained battery, the ABS warning light () may turn on at the same time. This happens because of the low battery voltage. It does not mean your ABS is malfunctioning. Have the battery recharged before driving the vehicle.

**Electronic Stability Control (ESC)**

The Electronic Stability Control (ESC) system helps to stabilize the vehicle during cornering maneuvers. ESC checks where you are steering and where the vehicle is actually going. ESC applies braking pressure to any one of the vehicle's brakes and intervenes in the engine management system to assist the driver with keeping the vehicle on the intended path. It is not a substitute for safe driving practices. Always adjust your speed and driving to the road conditions.

 **WARNING**

**Never drive too fast for the road conditions or too quickly when cornering. The ESC system will not prevent accidents.**

**Excessive speed in turns, abrupt maneuvers, and hydroplaning on wet surfaces can result in severe accidents.**

## ESC operation



### ESC ON condition

When the ignition switch is in the ON position, the ESC and the ESC OFF indicator lights illuminate for approximately three seconds and goes off, then the ESC is turned on. (After a new ignition cycle, the ESC ON mode is always activated (default setting).)

You may select between the following state of ESC:

- ESC NORMAL activated (ESC ON)
- ESC SPORT activated (ESC SPORT indicator illuminates)
- ESC deactivated (ESC OFF indicator illuminates)

## When operating

When the ESC is in operation, the ESC indicator light blinks:

- When you apply your brakes under conditions which may lock the wheels, you may hear sounds from the brakes, or feel a corresponding sensation in the brake pedal. This is normal and it means your ESC is active.
- When the ESC operates, the engine may not respond to the accelerator as it does under routine conditions.
- If the Cruise Control was in use when the ESC activates, the Cruise Control automatically disengages. The Cruise Control can be reengaged when the road conditions allow. **See "Cruise Control System" later in this chapter.** (if equipped)
- When moving out of the mud or driving on a slippery road, the engine rpm (revolutions per minute) may not increase even if you press the accelerator pedal deeply. This is to maintain the stability and traction of the vehicle and does not indicate a problem.

## Deactivating / Activating ESC

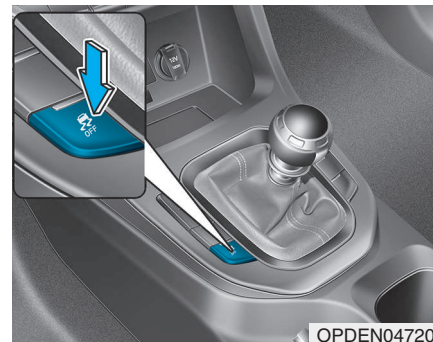

You may select between the following state of ESC:

- ESC NORMAL activated
- ESC SPORT activated (ESC SPORT indicator illuminates)
- ESC deactivated (ESC OFF indicator illuminates)

### WARNING

- If you deactivate ESC, ESC no longer stabilizes the vehicle. There is an increased risk of skidding and an accident.
- When ESC SPORT mode is activated, the stability support from ESC will be less than in "ESC ON mode", there is a greater risk of skidding and an accident.

**Only deactivate ESC or activate ESC SPORT in the situations described in the following.**

In the following situations, it may be better to activate ESC SPORT or deactivate ESC (ESC OFF):

- When using snow chains
- Driving in deep snow
- Driving in sand or gravel
- Driving on specially designed roads where oversteering and understeering characteristics are desired

We recommend only qualified and experienced drivers to drive the vehicle with the ESC deactivated or ESC SPORT activated.

### CAUTION

**After the above situations are over, activate ESC immediately. If not, the vehicle can be unstable due to vehicle slip or wheel spin.**

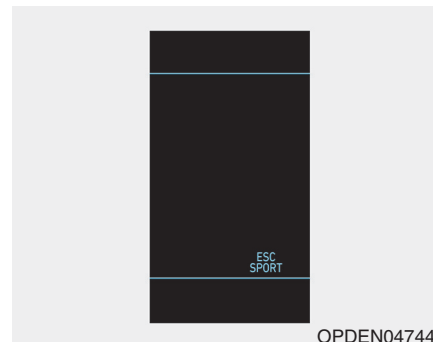

OPDEN047448

### ESC SPORT

#### • To activate ESC SPORT mode

Press the ESC OFF button briefly. The ESC SPORT indicator light illuminates on the cluster LCD display. In this state, ESC only stabilizes the vehicle to a limited degree.

When ESC SPORT mode is activated:

- ESC only improves driving stability to a limited degree.
- Traction control is still activated, but with less wheel control (more slip).
- Engine torque can partially be limited for the vehicle's stability and the driving wheel spin may be restricted for better traction.

- **To deactivate ESC SPORT mode**

Press the ESC OFF button briefly. The ESC SPORT indicator light will go off on the cluster LCD display.

### To deactivate ESC (ESC OFF)



Press and hold the ESC OFF button continuously for more than 3 seconds. The ESC OFF indicator light and message "Traction & Stability Control disabled" illuminates and a warning chime sounds. In this state, both the traction control function of ESC (engine management) and the brake control function of ESC (braking management) are disabled.

To activate the ESC again, briefly press the ESC OFF button. The ESC OFF indicator light will go off.

### Indicator lights

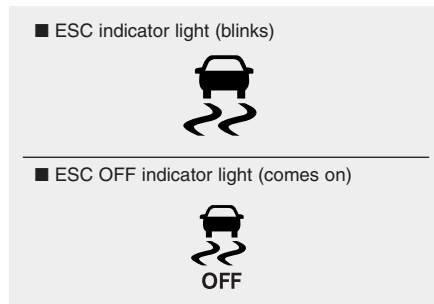

When the ignition switch is in the ON position, the ESC indicator light illuminates, then goes off if the ESC system is operating normally.

The ESC indicator light blinks whenever the ESC is operating.

If the ESC indicator light stays on, your vehicle may have a malfunction with the ESC system. When this warning light illuminates we recommend that the vehicle be checked by an authorized HYUNDAI dealer as soon as possible.

The ESC OFF indicator light comes on when the ESC is turned off with the button.

### WARNING

**When the ESC is blinking, this indicates the ESC is active:**

**Drive slowly and NEVER attempt to accelerate. NEVER turn the ESC off while the ESC indicator light is blinking or you may lose control of the vehicle resulting in an accident.**

### NOTICE

**Driving with wheels and tires with different sizes may cause the ESC system to malfunction. Before replacing tires, make sure all four tires and wheels are the same size. Never drive the vehicle with different sized wheels and tires installed.**

**⚠ WARNING**

**Don't use ESC SPORT mode or ESC OFF while using a minispare tire or a tire repair kit is in use!**

**ESC OFF usage**

**When Driving**

The ESC OFF mode should only be used briefly to help free the vehicle if stuck in snow or mud, by temporarily stopping operation of the ESC, to maintain wheel torque.

To turn ESC off while driving, press the ESC OFF button while driving on a flat road surface.

**NOTICE**

To prevent damage to the transmission:

- **Do not allow wheel(s) of one axle to spin excessively while the ESC, ABS, and parking brake warning lights are displayed. The repairs would not be covered by the vehicle warranty. Reduce engine power and do not spin the wheel(s) excessively while these lights are displayed.**
- **When operating the vehicle on a dynamometer, make sure the ESC is turned off (ESC OFF light illuminated).**

**i Information**

Turning the ESC off does not affect ABS or standard brake system operation.

**Drive mode selection**

When the ESC is on, the characteristic of ESC varies according to which drive mode is selected by pressing the DRIVE MODE or N button on the steering wheel.

Mode button	Selected mode	Characteristic of ESC
DRIVE MODE button	ECO mode	NORMAL
	NORMAL mode	NORMAL
	SPORT mode	NORMAL
N button	N mode	SPORT
	N CUSTOM mode	NORMAL/SPORT/OFF

For more details, refer to "Drive Mode Integrated Control System" in this chapter.



## CUSTOM mode

You may select the drive mode you prefer from the Audio or AVN screen.

- Select CUSTOM mode by pressing the N button on the steering wheel. The audio or AVN screen will display the CUSTOM mode menu. From the CUSTOM mode menu, select 'ESC → NORMAL / SPORT / OFF'.
- You may directly go to the CUSTOM mode menu by touching the audio or AVN screen. **For more details, refer to the Audio manual in chapter 4 or the separately supplied Multimedia manual.**



When ESC is turned off or on from the CUSTOM mode, you may not turn OFF/ON the system with the ESC OFF button. If the ESC OFF button is pressed, a message "ESC will be Off in CUSTOM mode. Hold flag button for 3 sec to continue" will appear on the cluster LCD display. You may change the state of ESC (NORMAL, SPORT, OFF) from the CUSTOM mode.

## Vehicle Stability Management

The Vehicle Stability Management (VSM) is a function of the Electronic Stability Control (ESC) system. It helps ensure the vehicle stays stable when accelerating or braking suddenly on wet, slippery and rough roads where traction over the four tires can suddenly become uneven.

### WARNING

**Take the following precautions when using the Vehicle Stability Management (VSM):**

- **ALWAYS** check the speed and the distance to the vehicle ahead. The VSM is not a substitute for safe driving practices.
- **Never drive too fast for the road conditions. The VSM system will not prevent accidents. Excessive speed in bad weather, slippery and uneven roads can result in severe accidents.**

### **VSM operation**

#### **VSM ON condition**

The VSM operates when:

- The Electronic Stability Control (ESC) is on.
- Vehicle speed is approximately above 15 km/h (9 mph) on curve roads.
- Vehicle speed is approximately above 20 km/h (12 mph) when the vehicle is braking on rough roads.

#### **When operating**



When you apply your brakes under conditions which may activate the ESC, you may hear sounds from the brakes, or feel a corresponding sensation in the brake pedal. This is normal and it means your VSM is active.

### **Information**

The VSM does not operate when:

- Driving on a banked road such as gradient or incline.
- Driving in reverse.
- The ESC OFF indicator light is on.
- The EPS (Electric power steering) warning light () is on or blinks.

### **WARNING**

If the ESC indicator light () or EPS warning light () stays or blinks, your vehicle may have a malfunction with the VSM system. When the warning light illuminates we recommend that the vehicle be checked by an authorized HYUNDAI dealer as soon as possible.

### **NOTICE**

Driving with wheels and tires with different sizes may cause the ESC system to malfunction. Before replacing tires, make sure all four tires and wheels are the same size. Never drive the vehicle with different sized tires and wheels installed.

## Hill-Start Assist Control (HAC)

The Hill-Start Assist Control (HAC) helps prevent the vehicle from rolling backwards when starting a vehicle from a stop on a hill. The system operates the brakes automatically for approximately 2 seconds and releases the brake after 2 seconds or when the accelerator pedal is depressed.

### WARNING

**Always be ready to depress the accelerator pedal when starting off on a incline. The HAC activates only for approximately 2 seconds.**

### Information

- The HAC does not operate when the shift lever is in P (Park) or N (Neutral).
- The HAC activates even when the ESC (Electronic Stability Control) is off. However, it does not activate, when the ESC does not operate normally.

## Emergency Stop Signal (ESS) (if equipped)

The Emergency Stop Signal system alerts the driver behind by blinking the stop lights, while sharply and severely braking.

The system is activated when:

- The vehicle suddenly stops. (The deceleration power exceeds  $7 \text{ m/s}^2$ , and the driving speed exceeds 55 km/h (34 mph).)
- The ABS is activated and the driving speed exceeds 55 km/h (34 mph).

The hazard warning flasher automatically turns ON after blinking the stop lights:

- When the driving speed is under 40 km/h (25 mph),
- When the ABS is deactivated, and
- When the sudden braking situation is over.

The hazard warning flasher turns OFF:

- When the vehicle drives at a low speed for a certain period of time.

The driver can manually turn OFF the hazard warning flasher by pressing the button.

### Information

**The Emergency Stop Signal (ESS) system will not activate, when the hazard warning flashers are already on.**

### Good braking practices

#### WARNING

**Whenever leaving the vehicle or parking, always come to a complete stop and continue to depress the brake pedal. Move the shift lever into 1st gear when the vehicle is parked on a uphill and in R (Reverse) on a downhill, then apply the parking brake, and place the ignition switch in the LOCK/OFF position.**

**Vehicles parked with the parking brake not applied or not fully engaged may roll inadvertently and may cause injury to the driver and others. ALWAYS apply the parking brake before exiting the vehicle.**

Wet brakes can be dangerous! The brakes may get wet if the vehicle is driven through standing water or if it is washed. Your vehicle will not stop as quickly if the brakes are wet. Wet brakes may cause the vehicle to pull to one side.

To dry the brakes, apply the brakes lightly until the braking action returns to normal, taking care to keep the vehicle under control at all times. If the braking action does not return to normal, stop as soon as it is safe to do so and we recommend that you call an authorized HYUNDAI dealer for assistance.

DO NOT drive with your foot resting on the brake pedal. Even light, but constant pedal pressure can result in the brakes overheating, brake wear, and possibly even brake failure.

If a tire goes flat while you are driving, apply the brakes gently and keep the vehicle pointed straight ahead while you slow down. When you are moving slowly enough for it to be safe to do so, pull off the road and stop in a safe location.

Keep your foot firmly on the brake pedal when the vehicle is stopped to prevent the vehicle from rolling forward.

## ELECTRONIC CONTROL SUSPENSION (ECS)

The Electronic Control Suspension (ECS) controls the vehicle suspension automatically to maximize driving comfort by taking into account the driving conditions such as speed, surface of the road, cornering, stopping requirements and acceleration.

### *System malfunction*

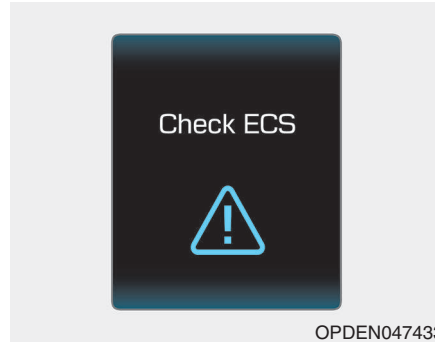

### **Check ECS**

If the ECS warning message comes on, you may have a problem with the ECS system. We recommend that you have the system checked by an authorized HYUNDAI dealer.

## ELECTRONIC LIMITED SLIP DIFFERENTIAL (IF EQUIPPED)

Electronic Limited Slip Differential refers to a feature equipped with a mechanism that controls the differential functions of the wheels.

The Electronic Limited Slip Differential helps:

- Improve handling performance when circling at high speed.
- Improve launching performance.
- Prevent slipping on rainy or snowy roads due to dissimilar friction of the left and right wheels.

### WARNING

**Never run wheels with one of them lifted by the jack. It is extremely dangerous for a vehicle equipped with Electronic Limited Slip Differential.**

### *Drive mode selection*

The characteristic of e-LSD varies according to which drive mode is selected by pressing the DRIVE MODE or N button on the steering wheel.

Mode button	Selected mode	Characteristic of e-LSD
DRIVE MODE button	ECO mode	NORMAL
	NORMAL mode	NORMAL
	SPORT mode	SPORT
N button	N mode	SPORT
	N CUSTOM mode	NORMAL/SPORT

**For more details, refer to "Drive Mode Integrated Control System" in this chapter.**

### **CUSTOM mode**

You may select the drive mode you prefer from the Audio or AVN screen.

- Select CUSTOM mode by pressing the N button on the steering wheel. The audio or AVN screen will display the CUSTOM mode menu. From the CUSTOM mode menu, select 'e-LSD → NORMAL/SPORT'.
- You may directly go to the CUSTOM mode menu by touching the audio or AVN screen. **For more details, refer to the Audio manual in chapter 4 or the separately supplied Multimedia manual.**

## Warning messages

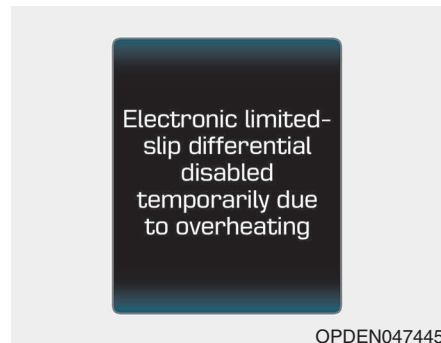

### Electronic Limited Slip Differential disabled temporarily due to overheating

Overheating of related parts will temporarily disable e-LSD. Wait until the vehicle cools down.

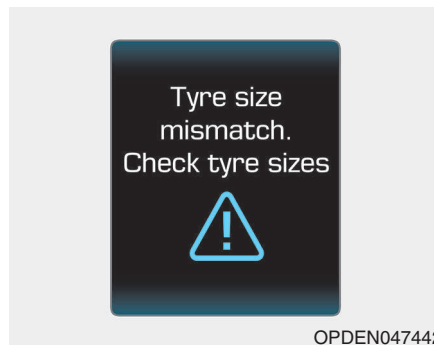

### Tyre size mismatch. Check tyre sizes

If your vehicle is equipped with different tires (size, type, etc.) on the front, the message will appear. To use the Electronic Limited Slip Differential, equip the vehicle with the same tires on the front.

## System malfunction

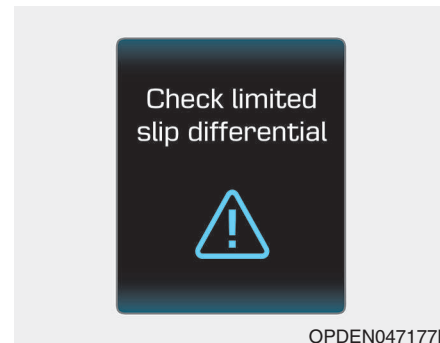

### Check limited slip differential

If the Electronic Limited Slip Differential warning message comes on, you may have a problem with the Electronic Limited Slip Differential system. We recommend that you have the system checked by an authorized HYUNDAI dealer

## DRIVE MODE INTEGRATED CONTROL SYSTEM

### DRIVE MODE button

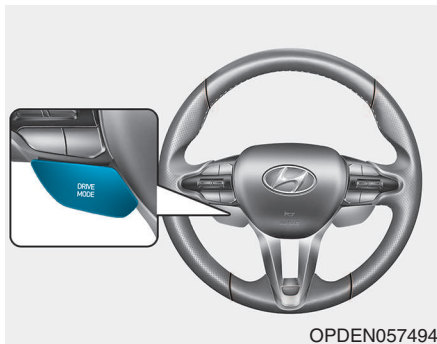

The drive mode may be selected according to the driver's preference or road condition.

The system resets to be in the NORMAL mode, when the engine is restarted.

The mode changes, whenever the DRIVE MODE button is pressed.

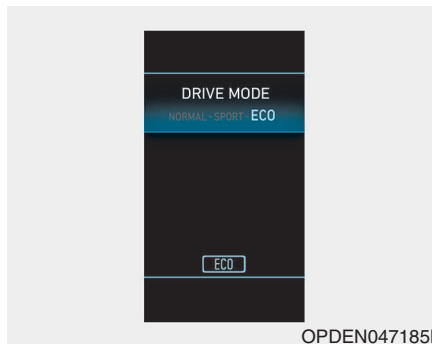

### ECO mode



When the Drive Mode is set to ECO mode, the engine and transmission control logic are changed to maximize fuel efficiency.

- When the ECO mode is selected by pressing the DRIVE MODE button, the ECO indicator will illuminate.

### **i** Information

**Fuel efficiency depends on the driver's driving habit and road condition.**

#### **When ECO mode is activated:**

- The acceleration response may be slightly reduced as the accelerator pedal is depressed moderately.
- The air conditioner performance may be limited.
- The shift pattern of the automatic transmission may change.
- The engine noise may get louder.

The above situations are normal conditions when ECO mode is activated, to improve fuel efficiency.



### Limitation of ECO mode operation:

If the following conditions occur while ECO mode is operating, the system operation is limited even though there is no change in ECO indicator.

- When the coolant temperature is low:

The system will be limited until engine performance becomes normal.

- When driving up a hill:

The system will be limited to gain power when driving uphill because engine torque is restricted.

The system will be limited due to the shift location.

- When the accelerator pedal is deeply depressed for a few seconds:

The system will be limited, judging that the driver wants to speed up.

### SPORT mode

**SPORT**

SPORT mode manages the driving dynamics by automatically adjusting the steering effort, the engine and transmission control logic for enhanced driving performance.

- When SPORT mode is selected by pressing the DRIVE MODE button, the SPORT indicator will illuminate.
- When SPORT mode is activated:
  - The engine rpm will tend to remain raised over a certain length of time even after releasing the accelerator
  - Upshifts are delayed when accelerating

### **i** Information

**In SPORT mode, the fuel efficiency may decrease.**

### N button

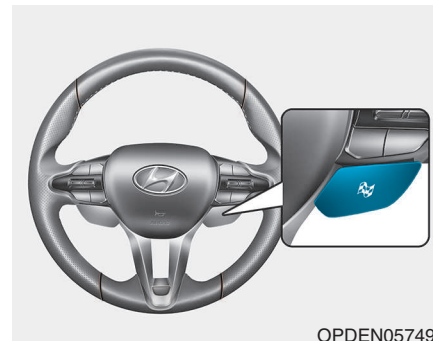

OPDEN057495

N mode or CUSTOM mode may be selected by pressing the N button.

The system resets to be in the NORMAL mode, when the engine is restarted.

The mode changes, whenever the N button is pressed.

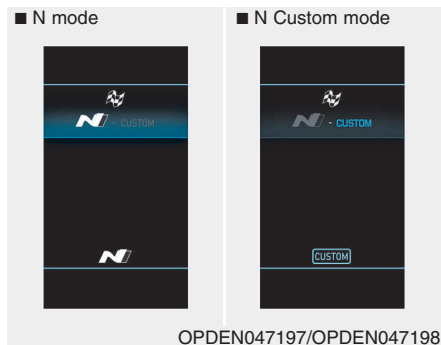

### **N mode**



N mode selects the proper driving mode among SPORT and SPORT+ for each components that will effect the performance of a high-performance vehicle.

- When N mode is selected by pressing the N button, the N indicator will illuminate.
- N mode (SPORT/SPORT+) manages the driving dynamics by automatically adjusting the steering effort, and the engine and transmission control logic for enhanced driver performance.
- When N mode (SPORT/SPORT+) is activated:
  - The engine rpm will tend to remain raised over a certain length of time even after releasing the accelerator
  - Upshifts are delayed when accelerating

### **NOTICE**

**In SPORT/SPORT+ mode, the fuel efficiency may decrease.**

### **CUSTOM mode**



In CUSTOM mode, the driver can select the drive mode for each component they prefer on the audio or AVN screen.

- Engine : NORMAL/SPORT/SPORT+
- Rev matching : OFF/NORMAL/SPORT/SPORT+
- E-LSD (Electronic Limited Slip Differential) : NORMAL/SPORT
- Suspension : NORMAL/SPORT/SPORT+
- Steering : NORMAL/SPORT/SPORT+
- ESC (Electronic Stability Control) : NORMAL/SPORT/OFF
- Exhaust sound : NORMAL/SPORT/SPORT+

**For more details, refer to the Audio manual in chapter 4 or the separately supplied Multimedia manual.**

## Vehicle characteristic

The characteristic of each component varies according to which drive mode is selected by pressing the DRIVE MODE or N button on the steering wheel.

	Component	DRIVE MODE Button			N Button	
		ECO mode	NORMAL mode	SPORT mode	N mode	CUSTOM mode
Engine & Driving	Engine	ECO	NORMAL	SPORT	SPORT+	NORMAL / SPORT / SPORT+
	Rev matching	OFF	NORMAL	SPORT	SPORT+	OFF / NORMAL / SPORT / SPORT+
	e-LSD *1	NORMAL	NORMAL	SPORT	SPORT	NORMAL / SPORT
Chassis	Suspension	NORMAL	NORMAL	SPORT	SPORT+	NORMAL / SPORT / SPORT+
	Steering	NORMAL	NORMAL	SPORT	SPORT+	NORMAL / SPORT / SPORT+
	ESC *2	NORMAL	NORMAL	NORMAL	SPORT	NORMAL / SPORT / OFF
Sound	Exhaust sound *3	ECO	NORMAL	SPORT	SPORT+	NORMAL / SPORT / SPORT+

The information provided may differ depending on which features are applicable to your vehicle.

\*1 : Electronic Limited Slip Differential

\*2 : Electronic Stability Control

\*3 : a) The volume of the exhaust sound made by the exhaust gas flap (if equipped) changes according to the mode selected.

**[Quietest]** ECO/NORMAL mode < SPORT mode < N mode **[Loudest]**

b) An exhaust crackle sound, to deliver emotional effect, is produced while driving when the accelerator pedal is released right after being depressed. This exhaust sound effect will be heard when SPORT+ is selected for the Sound component. To turn it off, select NORMAL or SPORT for the Engine component in CUSTOM mode.

### ISG (IDLE STOP AND GO) SYSTEM (IF EQUIPPED)

The ISG system is to reduce the fuel consumption by automatically shutting down the engine, when the vehicle is at a standstill (i.e. red stop light, stop sign, and traffic jam).

The engine is automatically started upon satisfying the starting conditions.

The ISG system is always active, when the engine is running.

#### **i** Information

When the engine is automatically started by the ISG system, some warning lights (i.e. ABS, ESC, ESC OFF, EPS, and parking brake warning light) may illuminate for a few seconds due to the low battery voltage. However, it does not indicate a malfunction with the ISG system.

#### To activate the ISG system

##### **Prerequisite for activation**

The ISG system operates in the following situations.

- The driver's seatbelt is fastened.
- The driver's door and the hood are closed.
- The brake vacuum pressure is adequate.
- The battery is sufficiently charged.
- The outside temperature is between -10 °C and 35 °C (14 °F and 95 °F).
- The engine coolant temperature is not too low.
- The system is not in the diagnostic mode.

#### **i** Information

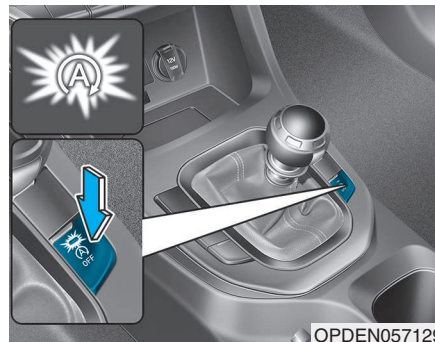

- The ISG system is not activated, when the prerequisites to activate the ISG system are unsatisfied. In this case, the ISG OFF button indicator illuminates, and the auto stop indicator (A) illuminates in yellow on the instrument cluster.
- When the above indicator remains illuminated on the instrument cluster, we recommend that you have the ISG system checked by an authorized HYUNDAI dealer.

## Auto stop

To stop the engine in idle stop mode



1. Decrease the vehicle speed to 5 km/h (3 mph).
2. Set the gear in N (Neutral).
3. Release the clutch pedal.

The auto stop indicator () illuminates in green on the instrument cluster, when the engine stops.

### Information

The driving speed must reach at least 10 km/h (6 mph) after an idle stop to stop the engine in idle stop mode again.

In auto stop mode, when the driver opens the hood, the ISG system will be deactivated.

When the system is deactivated:

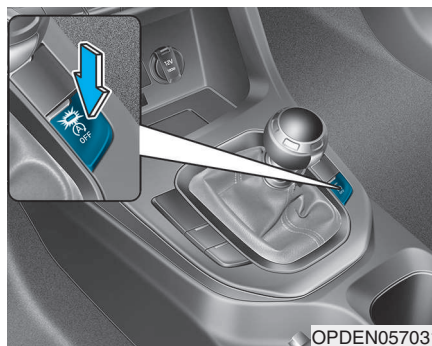

The ISG OFF button indicator illuminates.

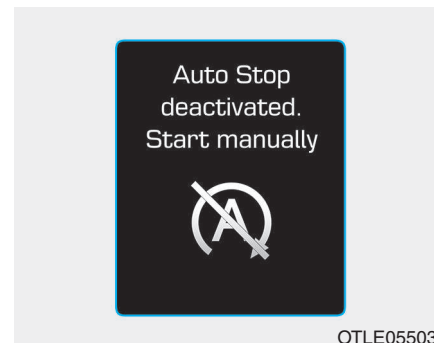

The message, "Auto Stop deactivated. Start manually", appears on the LCD display with a beep sound.

At this time, restart the vehicle manually by:

Depressing the clutch and brake pedal with the gear in neutral.

### **Auto start**

To restart the engine in the auto stop mode

- Depress the clutch pedal with the gear in N (Neutral).

The auto stop indicator ((A)) goes OFF on the instrument cluster, when the engine is restarted.

The engine is automatically restarted in the following situations.

- The fan speed of the manual climate control system is set above the 3rd position, with the air condition ON.
- The fan speed of the automatic climate control system is set above the 6th position, with the air condition ON.
- A certain period of time has elapsed with the air condition ON.
- The defroster is activated.
- The brake vacuum pressure is low.
- The battery is weak.
- The driving speed exceeds 5 km/h (3 mph).

The auto stop indicator ((A)) blinks in green for 5 seconds on the instrument cluster and a message "Auto Start" will appear on the LCD display.

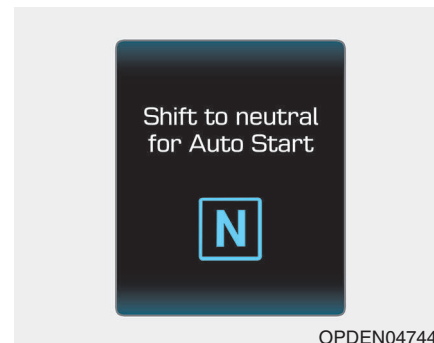

The auto start is temporarily deactivated in the following situations.

When the clutch pedal is depressed without shifting the gear to neutral, a message "Shift to neutral for Auto Start" will appear on the cluster LCD display. To activate auto start, shift to neutral and depress the clutch pedal.

## To deactivate the ISG system

- Press the ISG OFF button to deactivate the ISG system. Then, the ISG OFF button indicator illuminates, and the message "Auto Stop System Off" appears on the LCD display.
- Press the ISG OFF button again to reactivate the ISG system. Then, the ISG OFF button indicator turns OFF.

## ISG system malfunction

### The ISG system may not operate:

When there is a malfunction with the ISG sensors or the ISG system.

### The followings occur, when there is a malfunction with the ISG system:

- The auto stop indicator ((A)) will blink in yellow on the instrument cluster.
- The light on the ISG OFF button will illuminate.

## Information

- When you cannot turn OFF the ISG OFF button indicator by pressing the ISG OFF button, or when the malfunction with the ISG system persists, we recommend that you contact an authorized HYUNDAI dealer.
- You can turn off the ISG OFF button indicator by driving over 80 km/h (50 mph) for up to 2 hours with the fan speed below the 2nd position. If the ISG OFF button indicator remains ON, we recommend that you contact an authorized HYUNDAI dealer.

## WARNING

When the engine is in auto stop mode, the engine may restart. Before leaving the vehicle or checking the engine compartment, stop the engine by placing the ignition switch to the LOCK/OFF position or removing the ignition key.

### The battery sensor deactivation

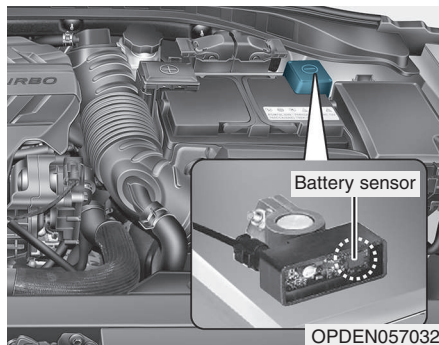

The battery sensor is deactivated, when the battery is disconnected from the negative pole for maintenance purpose.

In this case, the ISG system is limitedly operated due to the battery sensor deactivation. Thus, the driver needs to take the following procedures to reactivate the battery sensor after disconnecting the battery.

### ***Prerequisites to reactivate the battery sensor***

Keep the engine in the OFF status for 4 hours, and attempt to restart the engine 3 to 4 times for the battery-sensor reactivation.

Pay extreme caution not to connect any accessories (i.e. navigation and black box) to the vehicle with the engine in the OFF status. If not, the battery sensor may not be reactivated.

### **i Information**

The ISG system may not operate in the following situations.

- There is a malfunction with the ISG system.
- The battery is weak.
- The brake vacuum pressure is low.

In those cases, we recommend that you have the ISG system checked by an authorized HYUNDAI dealer.

### **NOTICE**

- Use only the genuine HYUNDAI ISG battery for replacement. If not, the ISG system may not normally operate.
- Do not recharge the ISG battery with a general battery charger. If not, it may damage or explode the ISG battery.
- Do not remove the battery cap. If not, the battery electrolyte, which is harmful to the human body, may leak out.



## AUTONOMOUS EMERGENCY BRAKING (AEB) – CAMERA TYPE (IF EQUIPPED)

The Autonomous Emergency Braking (AEB) system is designed to help detect and monitor the vehicle ahead in the roadway through camera recognition to warn the driver that a collision is imminent, and if necessary, apply emergency braking.

*The camera type AEB system does not detect pedestrians.*

### WARNING

**Take the following precautions when using the Autonomous Emergency Braking (AEB):**

- **This system is only a supplemental system and it is not intended to, nor does it replace the need for extreme care and attention of the driver. The sensing range and objects detectable by the sensors are limited. Pay attention to the road conditions at all times.**
- **NEVER drive too fast in accordance with the road conditions or while cornering.**
- **Always drive cautiously to prevent unexpected and sudden situations from occurring. AEB does not stop the vehicle completely and is not a collision avoidance system.**

### System setting and activation

#### System setting

- The driver can activate the AEB by placing the ignition switch to the ON position and by selecting: 'User Settings → Driving Assist → Autonomous Emergency Braking'

The AEB deactivates, when the driver cancels the system setting.



The warning light illuminates on the LCD display, when you cancel the AEB system. The driver can monitor the AEB ON/OFF status on the LCD display. Also, the warning light illuminates when the ESC (Electronic Stability Control) is turned off. If the warning light remains ON when the AEB is activated, we recommend that you have the system checked by an authorized HYUNDAI dealer.

- The driver can select the initial warning activation time on the LCD display.

Go to the 'User Settings → Driving Assist → Forward Collision Warning → Late/Normal/Early'.

The options for the initial Forward Collision Warning includes the following:

- Early:

When this condition is selected, the initial Forward Collision Warning is activated earlier than normal. This setting maximizes the amount of distance between the vehicle ahead before the initial warning occurs.

Even though, 'Early' is selected if the front vehicle suddenly stops the initial warning activation time may not seem fast.

- Normal:

When this condition is selected, the initial Forward Collision Warning is activated normally. This setting allows for a nominal amount of distance between the vehicle ahead before the initial warning occurs.

- Late:

When this condition is selected, the initial Forward Collision Warning is activated later than normal. This setting reduces the amount of distance between the vehicle ahead before the initial warning occurs.

Select 'Late' when traffic is light and when driving speed is slow.

### ***Prerequisite for activation***

The AEB gets ready to be activated, when the AEB is selected on the LCD display, and when the following prerequisites are satisfied.

- The ESC (Electronic Stability Control) is on.
- Vehicle speed is over 10 km/h (6 mph). (The AEB is only activated within a certain speed range.)
- The system detects vehicle in front, which may collide with your vehicle. (The AEB may not be activated or may sound a warning alarm in accordance with the driving situation or vehicle condition.)

## WARNING

- **Completely stop the vehicle on a safe location before operating the switch on the steering wheel to activate/deactivate the AEB system.**
- **The AEB automatically activates upon placing the Engine Start/Stop button to the ON position. The driver can deactivate the AEB by canceling the system setting on the LCD display.**
- **The AEB automatically deactivates upon canceling the ESC (Electronic Stability Control). When the ESC is canceled, the AEB cannot be activated on the LCD display. The AEB warning light will illuminate which is normal.**

## AEB warning message and system control

The AEB produces warning messages and warning alarms in accordance with the collision risk levels, such as abrupt stopping of the vehicle in front, insufficient braking distance, or detection. Also, it controls the brakes in accordance with the collision risk levels.

The driver can select the initial warning activation time in the User Settings in the LCD display. The options for the initial Forward Collision Warning include Early, Normal or Late initial warning time.

## Forward Warning (1<sup>st</sup> warning)

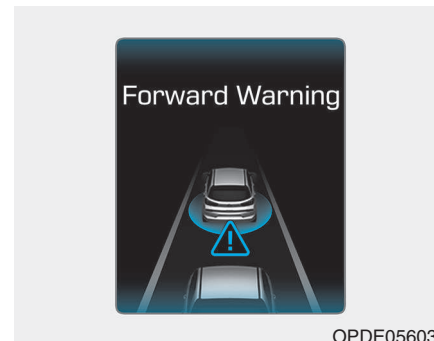

OPDE056036

This initial warning message appears on the LCD display with a warning chime.

### Collision Warning (2<sup>nd</sup> warning)

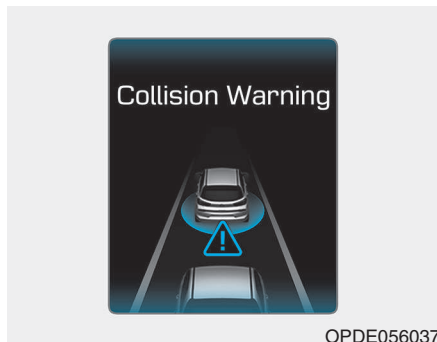

This warning message appears on the LCD display with a warning chime. Additionally, some vehicle system intervention occurs by the engine management system to help decelerate the vehicle.

- Your vehicle speed may decelerate moderately.
- The AEB system limitedly controls the brakes to preemptively mitigate impact in a collision.

### Emergency braking (3<sup>rd</sup> warning)

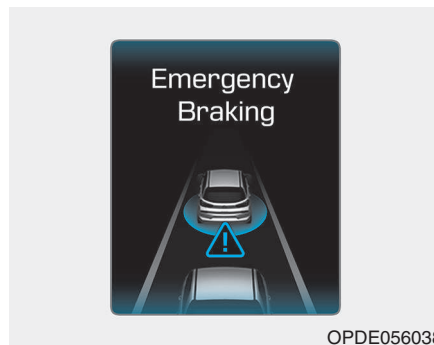

This warning message appears on the LCD display with a warning chime.

Additionally, some vehicle system intervention occurs by the engine management system to help decelerate the vehicle.

- The AEB system limitedly controls the brakes to preemptively mitigate impact in a collision. The brake control is maximized just before a collision.

### Brake operation

- In an urgent situation, the braking system enters into the ready status for prompt reaction against the driver's depressing the brake pedal.
- The AEB provides additional braking power for optimum braking performance, when the driver depresses the brake pedal.
- The braking control is automatically deactivated, when the driver sharply depresses the accelerator pedal, or when the driver abruptly operates the steering wheel.
- The AEB brake control is automatically canceled, when risk factors disappear.

#### CAUTION

**The driver should always use extreme caution while operating the vehicle, whether or not there is a warning message or alarm from the AEB system.**

**⚠ WARNING**

The braking control cannot completely stop the vehicle nor avoid all collisions. The driver should hold the responsibility to safely drive and control the vehicle.

**⚠ WARNING**

The AEB system logic operates within certain parameters, such as the distance from the vehicle ahead, the speed of the vehicle ahead, and the driver's vehicle speed. Certain conditions such as inclement weather and road conditions may affect the operation of the AEB system.

**⚠ WARNING**

Never deliberately drive dangerously to activate the system.

### AEB sensor

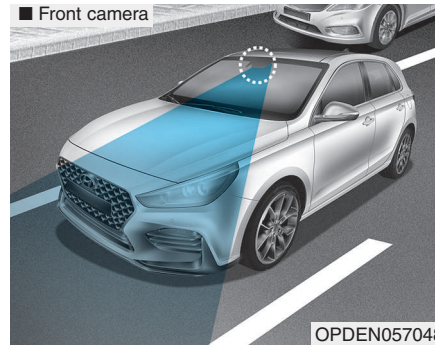

In order for the AEB system to operate properly, always make sure the camera is clean and free of dirt, snow, and debris. Dirt, snow, or foreign substances on the lens may adversely affect the sensing performance of the camera.

**NOTICE**

The sensing performance of the sensor may be affected if the following instructions are not followed.

- Always keep the camera sensor clean and free of dirt and debris.
- Use only genuine parts to repair or replace a damaged sensor.

**NOTICE**

Be careful not to apply unnecessary force on the camera sensor. If the sensor is forcibly moved out of proper alignment, the AEB system may not operate correctly. In this case, a warning message may not be displayed. Have the vehicle inspected by an authorized HYUNDAI dealer.

### NOTICE

- **NEVER** install any accessories or stickers on the front windshield, nor tint the front windshield.
- **NEVER** locate any reflective objects (i.e. white paper, mirror) over the dashboard. Any light reflection may cause a malfunction of the system.
- Pay extreme caution to keep the camera out of water.
- **NEVER** arbitrarily disassemble the camera assembly, nor apply any impact on the camera assembly.
- Playing the vehicle audio system at high volume may offset the system warning sounds.

### **i** Information

We recommend that you have the system checked by an authorized HYUNDAI dealer when:

- The windshield glass is replaced.
- The camera or related parts are repaired or removed.

### Warning message and warning light

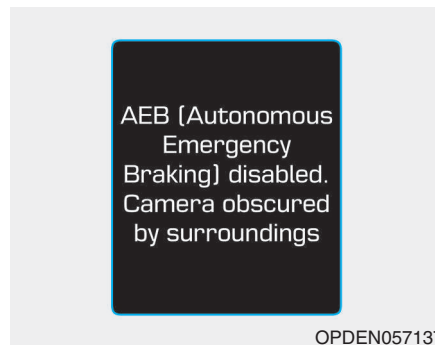

#### **AEB (Autonomous Emergency Braking) disabled. Camera obscured by surroundings**

When the camera sensor is blocked with dirt, snow, or debris, the AEB system operation may stop temporarily. If this occurs, a warning message will appear on the LCD display.

Remove any dirt, snow, or debris and clean the camera sensor cover before operating the AEB system. The system will operate normally when such dirt, snow or debris is removed.

The AEB may not properly operate in an area (e.g. open terrain), where any substances are not detected after turning ON the engine.

## System malfunction

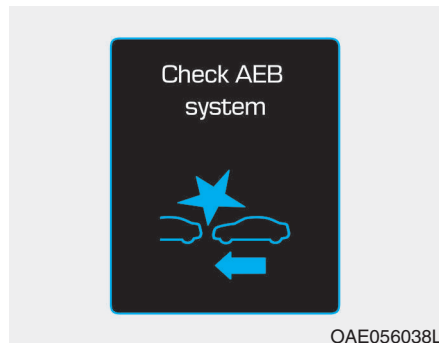

### Check AEB system

- When the AEB is not working properly, the AEB warning light (🚨) will illuminate and the warning message will appear for a few seconds. After the message disappears, the master warning light (⚠️) will illuminate. In this case, we recommend that you have the vehicle inspected by an authorized HYUNDAI dealer.
- The AEB warning message may appear along with the illumination of the ESC (Electronic Stability Control) warning light.

## ⚠️ WARNING

- The AEB is only a supplemental system for the driver's convenience. The driver should hold the responsibility to control the vehicle operation. Do not solely depend on the AEB system. Rather, maintain a safe braking distance, and, if necessary, depress the brake pedal to reduce the driving speed.
- In certain instances and under certain driving conditions, the AEB system may activate unintentionally. This initial warning message appears on the LCD display with a warning chime.  
**Also, in certain instances the front camera recognition system may not detect the vehicle ahead. The AEB system may not activate and the warning message will not be displayed.**

(Continued)

(Continued)

- Even if there is any problem with the brake control function of the AEB system, the vehicle's basic braking performance will operate normally. However, brake control will not activate.
- If the vehicle in front stops suddenly, you may have less control of the brake system. Therefore, always keep a safe distance between your vehicle and the vehicle in front of you.
- The AEB system may activate during braking and the vehicle may stop suddenly shifting loose objects toward the passengers. Always keep loose objects secured.
- The AEB system may not activate if the driver applies the brake pedal to avoid a collision.

### **WARNING**

- **The AEB system operates only to detect vehicles in front of the vehicle.**
- **The AEB system does not operate when the vehicle is in reverse.**
- **The AEB system is not designed to detect other objects on the road such as animals.**
- **The AEB system does not detect vehicles in the opposite lane.**
- **The AEB system does not detect cross traffic vehicles that are approaching.**
- **The AEB system cannot detect the driver approaching the side view of a parked vehicle (for example on a dead end street.)**

**In these cases, you must maintain a safe braking distance, and if necessary, depress the brake pedal to reduce the driving speed in order to maintain a safe distance.**

### **Limitations of the system**

The Autonomous Emergency Braking (AEB) system is designed to monitor the vehicle ahead on the roadway through camera recognition to warn the driver that a collision is imminent, and if necessary, apply emergency braking.

In certain situations, the camera may not be able to detect the vehicle ahead. In these cases, the AEB system may not operate normally. The driver must pay careful attention in the following situations where the AEB operation may be limited.

#### ***Detecting vehicles***

The sensor may be limited when:

- The camera is blocked with a foreign object or debris
- The camera lens is contaminated due to tinted, filmed or coated windshield, damaged glass, or stuck of foreign matter (sticker, bug, etc.) on the glass
- Inclement weather such as heavy rain or snow obscures the field of view of the camera

- There is interference by electromagnetic waves
- The camera sensor recognition is limited
- The vehicle in front is too small to be detected (for example a motorcycle or a bicycle, etc.)
- The vehicle in front is an oversize vehicle or trailer that is too big to be detected by the camera recognition system (for example a tractor trailer, etc.)
- The driver's field of view is not well illuminated (either too dark or too much reflection or too much back-light that obscures the field of view)
- The vehicle in front does not have their rear lights properly turned ON
- The outside brightness changes suddenly, for example when entering or exiting a tunnel
- When light coming from a street light or an oncoming vehicle is reflected on a wet road surface such as a puddle in the road
- The field of view in front is obstructed by sun glare



- The windshield glass is fogged up; a clear view of the road is obstructed
- The vehicle in front is driving erratically
- The vehicle is on unpaved or uneven rough surfaces, or road with sudden gradient changes.
- The vehicle is driven near areas containing metal substances as a construction zone, railroad, etc.
- The vehicle drives inside a building, such as a basement parking lot
- The adverse road conditions cause excessive vehicle vibrations while driving
- The sensor recognition changes suddenly when passing over a speed bump
- The vehicle in front is moving vertically to the driving direction
- The vehicle in front is stopped vertically
- The vehicle in front is driving towards your vehicle or reversing
- You are on roundabouts and the vehicle in front circles

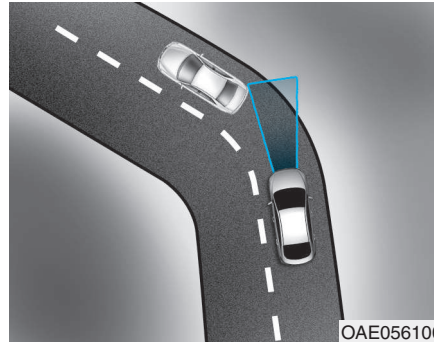

#### - Driving on a curve

The performance of the AEB system may be limited when driving on a curved road.

On curved roads, the other vehicle on the same lane is not recognized and the AEB system's performance may be degraded. This may result in unnecessary alarm or braking or no alarm or braking when necessary.

Also, in certain instances the front camera recognition system may not detect the vehicle traveling on a curved road.

In these cases, the driver must maintain a safe braking distance, and if necessary, depress the brake pedal to reduce your driving speed in order to maintain a safe distance.

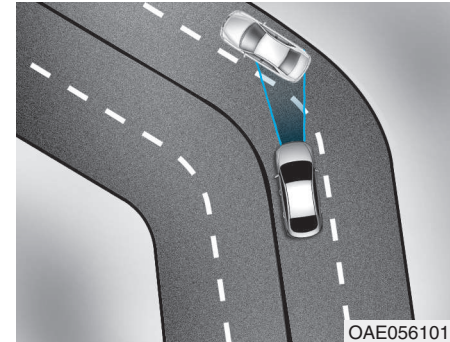

The AEB system may recognize a vehicle in the next lane when driving on a curved road.

In this case, the system may unnecessarily alarm the driver and apply the brake.

Always pay attention to road and driving conditions, while driving. If necessary, depress the brake pedal to reduce your driving speed in order to maintain a safe distance.

Also, when necessary depress the accelerator pedal to prevent the system from unnecessarily decelerating your vehicle.

Check to be sure that the road conditions permit safe operation of AEB.

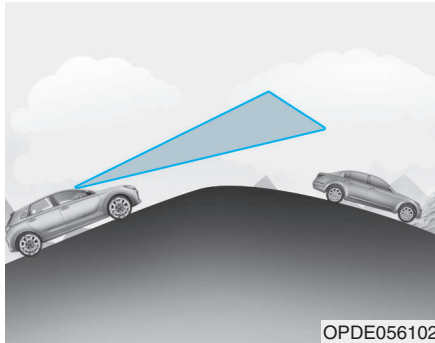

### - Driving on a slope

The performance of the AEB decreases while driving upward or downward on a slope, not recognizing the vehicle in front in the same lane. It may unnecessarily produce the warning message and the warning alarm, or it may not produce the warning message and the warning alarm at all.

When the AEB suddenly recognizes the vehicle in front while passing over a slope, you may experience sharp deceleration.

Always keep your eyes forward while driving upward or downward on a slope, and, if necessary, depress the brake pedal to reduce your driving speed in order to maintain distance.

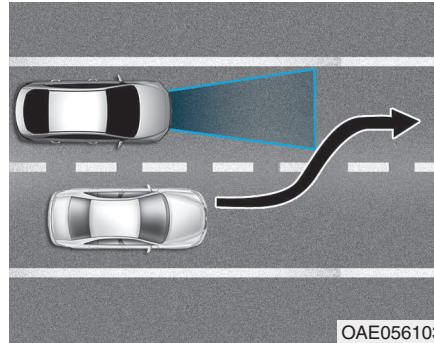

### - Changing lanes

When a vehicle changes lanes in front of you, the AEB system may not immediately detect the vehicle, especially if the vehicle changes lanes abruptly. In this case, you must maintain a safe braking distance, and if necessary, depress the brake pedal to reduce your driving speed in order to maintain a safe distance.

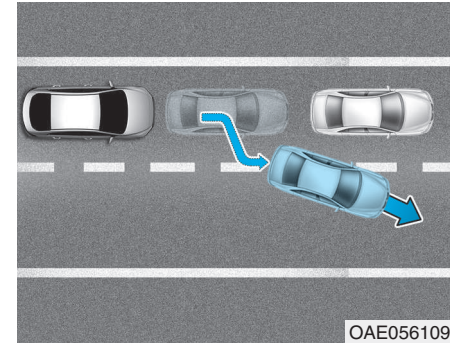

When driving in stop-and-go traffic, and a stopped vehicle in front of you merges out of the lane, the AEB system may not immediately detect the new vehicle that is now in front of you. In this case, you must maintain a safe braking distance, and if necessary, depress the brake pedal to reduce your driving speed in order to maintain a safe distance.

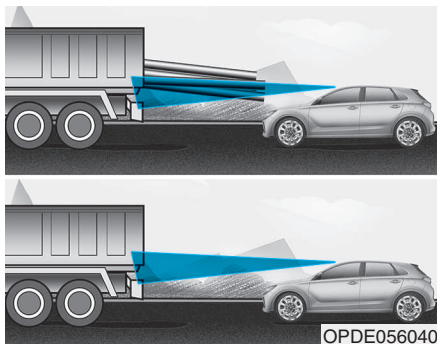

- Detecting the vehicle in front of you  
If the vehicle in front of you has cargo that extends rearward from the cab, or when the vehicle in front of you has higher ground clearance, additional special attention is required. The AEB system may not be able to detect the cargo extending from the vehicle. In these instances, you must maintain a safe braking distance from the rearmost object, and if necessary, depress the brake pedal to reduce your driving speed in order to maintain distance.

## **⚠** WARNING

- **Do not use the Autonomous Emergency Braking system when towing a vehicle. Application of the AEB system while towing may adversely affect the safety of your vehicle or the towing vehicle.**
- **Use extreme caution when the vehicle in front of you has cargo that extends rearward from the cab, or when the vehicle in front of you has higher ground clearance.**
- **The AEB system is designed to detect and monitor the vehicle ahead in the roadway through camera recognition. It is not designed to detect bicycles, motorcycles, or smaller wheeled objects such as luggage bags, shopping carts, or strollers.**
- **Never try to test the operation of the AEB system. Doing so may cause severe injury or death.**

## **i** Information

In some instances, the AEB system may be cancelled when subjected to electromagnetic interference.

## SPEED LIMIT INFORMATION FUNCTION (SLIF) (IF EQUIPPED)

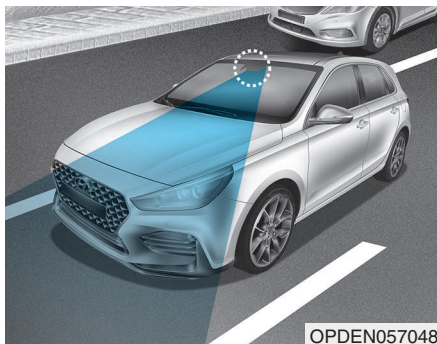

The SLIF displays the speed limit information and overtaking restriction through the instrument cluster and the navigation. The SLIF detects the traffic signs through the camera, which is attached on the upper part of the inner front windshield.

The SLIF also utilizes the navigation information to display the speed limit information.

### **!** WARNING

- **Speed Limit Information Function (SLIF) is only a supplemental system and is not always able to correctly display speed limits and overtaking restrictions.**
- **The driver still holds the responsibility not to exceed the maximum speed limit.**
- **Do not install any accessories and stickers. Do not tint the front windshield, especially near the rearview mirror.**
- **The SLIF detects the traffic signs through the camera to display the speed limit information.**  
**Therefore, the SLIF may not properly operate, when it is hard to detect the traffic signs. For further details, please refer to the "Limitations of the system".**
- **Pay extreme caution to keep the camera sensor out of water.**

(Continued)

(Continued)

- **Do not arbitrarily disassemble the camera assembly, nor apply any impact on the camera assembly.**
- **Do not locate any reflective objects (i.e. white paper, mirror) over the dashboard. Any light reflection may cause a malfunction system.**
- **The system is not available in all countries.**

### **i** Information

We recommend that you have the system checked by an authorized HYUNDAI dealer when:

- **The windshield glass is replaced.**
- **The camera or related parts are repaired or removed.**

## System setting and activation

### System setting

- The driver can activate the SLIF by selecting 'User Settings → Driving Assist → Speed Limit Information Function'.
- When the SLIF is activated, the symbols appear on the instrument cluster to display the speed limit information and overtaking restriction.
- When the SLIF is activated in the navigation setting, the above information and the restriction are also displayed on the navigation.

### System activation

- The SLIF displays the speed limit information and displays the overtaking restriction, when your vehicle passes by the relevant traffic signs.
- The SLIF restores the previous speed limit information, right after the ignition switch is placed to the ON position.
- You may find different speed limit information for the same road. The information is displayed depending on the driving situations. Because, traffic signs with additional sign (e.g. rainy, arrow, etc.) are also detected and compared with vehicle internal data (e.g. wiper operation, turn signal, etc.).

### **i** Information

**The speed limit information on the instrument cluster may differ from the one on the navigation. In this case, check the speed unit setting on the navigation.**

## Display

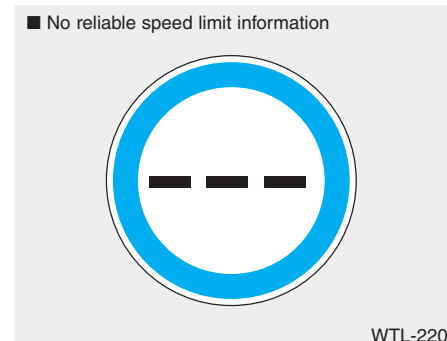

- The symbol is displayed on the instrument cluster and the navigation, when the SLIF does not have any reliable speed limit information.

### ■ No passing information

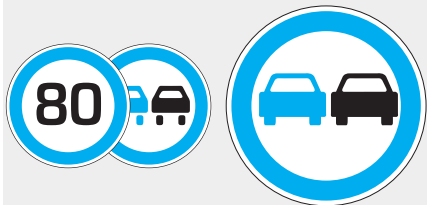

WTL-222/WTL-221

- The symbol is displayed on the instrument cluster and the navigation, when the SLIF detects a no-overtaking sign.

### ■ Unlimited speed (only in Germany)

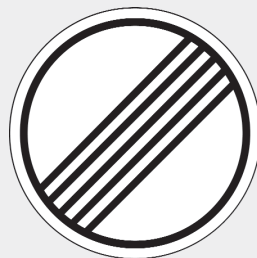

WUM-205

- The symbol, 'end of limitation', is displayed on the instrument cluster for the roads in Germany, which have no speed limit applicable. It is displayed, until the vehicle passes by another speed limit sign.

## Warning message

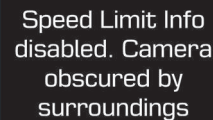

Speed Limit Info  
disabled. Camera  
obscured by  
surroundings

OPDEN057498

### **Speed Limit Info disabled. Camera obscured by surroundings**

The warning message appears, when the camera lens is blocked by some objects. The SLIF does not operate, until the objects are removed. Check the windshield glass around the camera area. If the problem persists after removing the objects, we recommend that you have the system checked by an authorized HYUNDAI dealer.



### Check SLIF

The warning message appears for a few seconds, when the SLIF does not properly operate. Then, the master warning light (▲) will illuminate. We recommend that you have the system checked by an authorized HYUNDAI dealer.

### Limitations of the system

The SLIF may not operate or may not provide correct information in the following situations.

#### When the traffic sign condition is poor

- The traffic sign is located on a sharp curve.
- The traffic sign is improperly positioned (i.e. turned over, blocked by an object, and damaged).
- Another vehicle blocks the traffic sign.
- The LED light of the traffic sign is broken.
- There is bright light around the traffic sign.
- The road signs do not correspond to the standard, etc.

#### When external condition is intervened

- Your vehicle drives right after another vehicle.
- The bus or truck, on which the speed sticker is attached, passes by your vehicle.

- Your vehicle drives in an area, which is uncovered by the navigation system.
- There is a malfunction with the navigation
- Your navigation has not been updated.
- Your navigation is being updated.
- There is something wrong with the GPS.
- The top speed limitations stored in the navigation system are incorrect.
- As a result of incorrect detection by the camera.
- The camera is calibrated right after the vehicle is delivered, etc.

#### When front visibility is poor

- The weather is bad, such as raining, snowing, and fogging.
- There is dirt, ice or frost on the front windshield, where the camera is installed.
- The camera lens is blocked by an object, such as sticker, paper, or fallen leaf, etc.

The driver must be cautious in the following situations. The SLIF may not assist the driver and may not properly operate.

- Do not disassemble the camera temporarily to tint the window or attach any types of coatings or accessories. If you disassemble the camera and assemble it again, we recommend that you take your vehicle to an authorized HYUNDAI dealer and have the system checked for calibration.
- Do not locate any reflective objects (i.e. white paper, mirror) over the dashboard. Any light reflection may cause a mal-function of the SLIF.  
Pay extreme caution to keep the camera sensor out of water.
- Do not arbitrarily disassemble the camera assembly, nor apply any impact on the camera assembly.

### LANE KEEPING ASSIST SYSTEM (LKAS) (IF EQUIPPED)

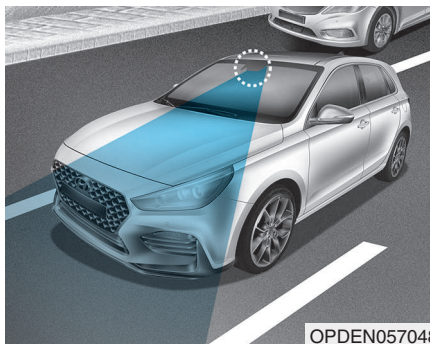

The Lane Keeping Assist System with a camera at the front windshield, helps detect lane markers on the road, and assists the driver's steering to help keep the vehicle between lanes.

When the system detects the vehicle straying from its lane, it alerts the driver with a visual and audible warning, while applying a slight counter-steering torque, trying to prevent the vehicle from moving out of its lane.

#### WARNING

**The Lane Keeping Assist System is not a substitute for safe driving practices, but a convenience function. It is the responsibility of the driver to always be aware of the surrounding and steer the vehicle.**

#### WARNING

**Take the following precautions when using the Lane Keeping Assist System (LKAS):**

- Do not steer the steering wheel suddenly when the steering wheel is being assisted by the system.
- LKAS helps to prevent the driver from moving out of the lane unintentionally by assisting the driver's steering. However, the driver should not solely rely on the system but always pay attention on the steering wheel to stay in the lane.

**(Continued)**



(Continued)

- The operation of the LKAS can be canceled or not work properly according to road condition and surroundings. Always be cautious when driving.
- Do not disassemble the LKAS camera temporarily to tint the window or attach any types of coatings and accessories. If you disassemble the camera and assemble it again, we recommend that you take your vehicle to an authorized HYUNDAI dealer and have the system checked for calibration.
- When you replace the windshield glass, LKAS camera or related parts of the steering wheel, we recommend that you take your vehicle to an authorized HYUNDAI dealer and have the system checked for calibration.

(Continued)

(Continued)

- The system detects lane markers and controls the steering wheel by a camera, therefore, if the lane markers are hard to detect, the system may not work properly. Please refer to "Limitations of the system".
- Do not remove or damage the related parts of LKAS.
- You may not hear a warning sound of LKAS because of excessive audio sound.
- Do not place objects on the dashboard that reflects light such as mirrors, white paper, etc. The system may malfunction if the sunlight is reflected.
- Always have your hands on the steering wheel while the LKAS system is activated. If you continue to drive with your hands off the steering wheel after the "Keep hands on steering wheel" warning message appears, the system will turn off automatically.

(Continued)

(Continued)

- After then, if you drive with your hands on the steering wheel, the control will be activated again.
- The steering wheel is not continuously controlled so if the vehicle speed is at a higher rate when leaving a lane the vehicle may not be controlled by the system. The driver must always follow the speed limit when using the system.
- If you attach objects to the steering wheel, the system may not assist steering or the hands off alarm may not work properly.
- When you tow a trailer, make sure that you turn off the LKAS system.

### LKAS operation

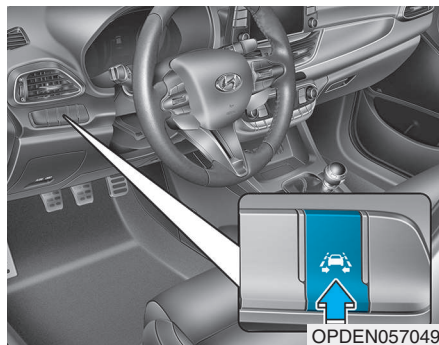

To activate/deactivate the LKAS:

With the ignition switch in the ON position, press the LKAS button located on the instrument panel on the left hand side of the steering wheel. (Right hand side of the steering wheel for RHD vehicles.)

The indicator in the cluster display will initially illuminate white. This indicates the LKAS is in the READY but NOT ENABLED state.

Note that the vehicle speed must be at least approximately 60 km/h (40 mph) to ENABLE the LKAS. The indicator in the cluster display will illuminate green.

5-66



The color of indicator will change depending on the condition of LKAS.

- White : Sensor does not detect lane markers or vehicle speed is under 60 km/h (40mph).
- Green : Sensor detects lane markers and the system is able to control vehicle steering.

### **i** Information

**If the indicator (white) is activated from the previous ignition cycle, the system will turn ON without any additional control. If you press the LKAS button again, the indicator on the cluster goes off.**

### LKAS activation

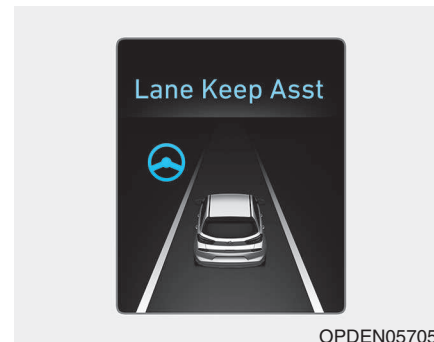

- To see the LKAS screen on the LCD display in the cluster, select Assist mode (A). For more details, refer to "LCD Display Modes" in chapter 3.
- When both lane markers are detected and all the conditions to activate the LKAS are satisfied, a green steering wheel indicator will illuminate and the LKAS indicator light will change from white to green. This indicates that the LKAS system is in the ENABLED state and the steering wheel will be able to be controlled.

## WARNING

The Lane Keeping Assist System is a system to prevent the driver from leaving the lane. However, the driver should not solely rely on the system but always check the road conditions when driving.

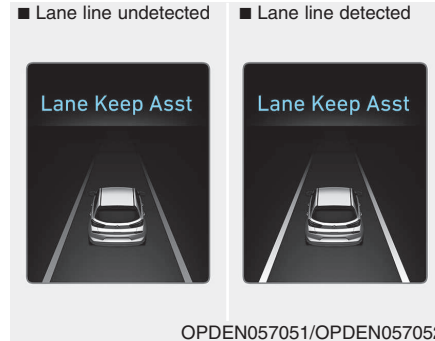

- If vehicle speed is over 60 km/h (40 mph) and the system detects lane markers, the color changes from gray to white.
- If the system detects the left lane marker, the left lane marker color will change from gray to white.
- If the system detects the right lane marker, the right lane marker color will change from gray to white.
- Both lane markers must be detected for the system to fully activate.

- If your vehicle speed exceeds 60 km/h (40 mph) and the LKAS button is ON, the system is enabled. If your vehicle departs from the projected lane in front of you, the LKAS operates as follows:



A visual warning appears on the cluster LCD display. Either the left lane marker or the right lane marker in the cluster LCD display will blink depending on which direction the vehicle is veering.

If the steering wheel appears, the system will control the vehicle's steering to prevent the vehicle from crossing the lane marker.

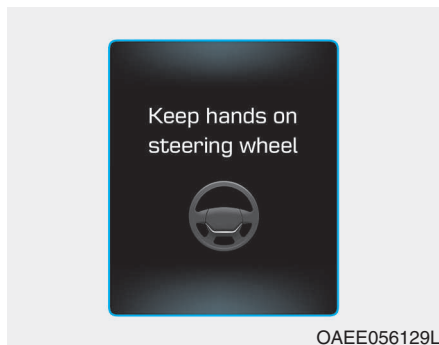

### Keep hands on steering wheel

If the driver takes their hands off the steering wheel for several seconds while the LKAS is activated, the system will warn the driver.

### **i** Information

**If the steering wheel is held very lightly the message may still appear because the LKAS system may not recognize that the driver has their hands on the wheel.**

### **⚠** WARNING

**The warning message may appear late according to road conditions. Therefore, always have your hands on the steering wheel while driving.**

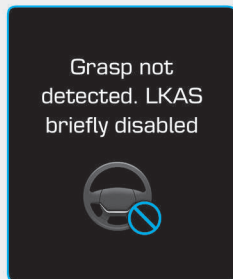

OPDEN057130

### Grasp not detected. LKAS briefly disabled

If the driver still does not have their hands on the steering wheel after the message "Keep hands on steering wheel", the system will not control the steering wheel and warn the driver only when the driver crosses the lane markers.

However, if the driver has their hands on the steering wheel again, the system will start controlling the steering wheel.

## WARNING

- The driver is responsible for accurate steering.
- Turn off the system and drive the vehicle in below situations.
  - In bad weather
  - In bad road condition
  - When the steering wheel needs to be controlled by the driver frequently.

### Information

- Even though the steering is assisted by the system, the driver may control the steering wheel.
- The steering wheel may feel heavier when the steering wheel is assisted by the system than when it is not.

## Warning light and message

### Check LKAS



OAAE056131L

If there is a problem with the system a message will appear for a few seconds. If the problem continues the LKAS failure indicator will illuminate.

### **LKAS failure indicator**



The LKAS failure indicator (yellow) will illuminate if the LKAS is not working properly. We recommend that the system be checked by an authorized HYUNDAI dealer.

#### **When there is a problem with the system do one of the following:**

- Turn the system on after turning the engine off and on again.
- Check if the ignition switch is in the ON position.
- Check if the system is affected by the weather. (ex: fog, heavy rain, etc.)
- Check if there is foreign matter on the camera lens.

If the problem is not solved, we recommend that the system be checked by an authorized HYUNDAI dealer.

#### **The LKAS system will not be in the ENABLED state and the steering wheel will not be assisted when:**

- There are more than two lane markers on the road. (e.g. construction area)
- The vehicle is driven on a steep incline.
- The steering wheel is turned suddenly.
- The turn signal is turned on before changing a lane. If you change lanes without the turn signal on, the steering wheel might be controlled.
- The vehicle is not driven in the middle of the lane when the system is turned on or right after changing a lane.
- The vehicle drives too close to the lane marker continuously before steering is assisted.
- ESC (Electronic Stability Control) or VSM (Vehicle Stability Management) is activated.
- The vehicle is driven on a sharp curve.
- Vehicle speed is below 60 km/h (37 mph) and over 200 km/h (125 mph).
- The vehicle makes sharp lane changes.
- The vehicle brakes suddenly.
- Only one lane marker is detected.
- The lane is very wide or narrow.

## Limitations of the system

The LKAS may operate prematurely even if the vehicle does not depart from the intended lane, OR, the LKAS may not assist your steering or warn you if the vehicle leaves the intended lane under the following circumstances:

### When the lane and road conditions are poor

- It is difficult to distinguish the lane marking from the road surface or the lane marking is faded or not clearly marked.
  - It is difficult to distinguish the color of the lane marker from the road.
  - There are markings on the road surface that look like a lane marker that is inadvertently being detected by the camera.
  - The lane marker is merged or divided. (e.g. tollgate)
  - The lane number increases or decreases or the lane marker are crossing complicatedly.
  - There are more than two lane markers on the road in front of you.
- The lane marker is very thick or thin.
  - The lanes ahead are not visible due to rain, snow, water on the road, damaged or stained road surface, or other factors.
  - The shadow is on the lane marker by a median strip, trees, etc.
  - The lanes are incomplete or the area is in a construction zone.
  - There are crosswalk signs or other symbols on the road.
  - The lane marker in a tunnel is stained with oil, etc.
  - The lane suddenly disappears such as at the intersection.

### When external condition is intervened

- The brightness outside changes suddenly such as when entering or exiting a tunnel, or when passing under a bridge.
- The brightness outside is too low such as when the headlamps are not on at night or the vehicle is going through a tunnel.
- There is a boundary structure in the roadway such as a concrete barrier, guardrail and reflector post that is inadvertently being detected by the camera.
- When light coming from a street light or an oncoming vehicle is reflected on a wet road surface such as a puddle in the road.
- The field of view in front is obstructed by sun glare.
- There is not enough distance between you and the vehicle in front to be able to detect the lane marker or the vehicle ahead is driving on the lane marker.
- Driving on a steep grade, over a hill, or when driving on a curved road.

- The adverse road conditions cause excessive vehicle vibrations while driving.
- The surrounding of the inside rear view mirror temperature is high due to direct sunlight, etc.

### **When front visibility is poor**

- The windshield or the LKAS camera lens is blocked with dirt or debris.
- The windshield glass is fogged up; a clear view of the road is obstructed.
- Placing objects on the dashboard, etc.
- The sensor cannot detect the lane because of fog, heavy rain or snow.

### **LKAS function change**

The driver can change LKAS to Lane Departure Warning System (LDWS) or change the LKAS mode between Standard LKA and Active LKA from the LCD display. Go to the 'User Settings → Driving Assist → Lane Keeping Assist System → Lane Departure Warning/Standard LKA/Active LKA'.

The system is automatically set to Standard LKA if a function is not selected.

### **Lane Departure Warning**

LDWS alerts the driver with a visual warning and a warning alarm when the system detects the vehicle departing the lane. The steering wheel will not be controlled.

### **Standard LKA**

The Standard LKA mode guides the driver to help keep the vehicle within the lanes. It rarely controls the steering wheel, when the vehicle drives well inside the lanes. However, it starts to control the steering wheel, when the vehicle is about to deviate out of the lanes.

### **Active LKA**

The Active LKA mode provides more frequent steering wheel control in comparison with the Standard LKA mode. Active LKA can reduce the driver's fatigue to assist the steering for maintaining the vehicle in the middle of the lane.



## LANE DEPARTURE WARNING SYSTEM (LDWS) (IF EQUIPPED)

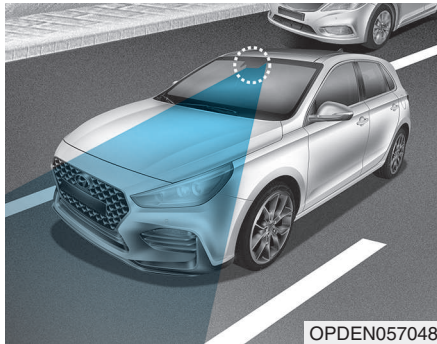

This Lane Departure Warning System detects the lane with the sensor at the front windshield and warns you when your vehicle leaves the lane.

### WARNING

The Lane Departure Warning System is not a substitute for safe driving practices, but a convenience function. It is the responsibility of the driver to always be aware of the surrounding and steer the vehicle.

### WARNING

Take the following precautions when using the Lane Departure Warning System (LDWS):

- **ALWAYS** check your surroundings and the road conditions before changing lanes. The LDWS does not control the vehicle to change lanes or to stay in the current lane.
- Do not make abrupt maneuvers or turn the steering wheel suddenly if the LDWS alerts you that the vehicle is departing from the lane.
- If the camera recognition system does not properly detect the lane, the LDWS may not notify you if the vehicle departs from the lane.
- The LDWS does not operate until the vehicle speed reaches approximately 60 km/h (37 mph).

(Continued)

(Continued)

- Do not disassemble the LDWS camera temporarily to tint the window or attach any types of coatings and accessories. If you disassemble the camera and assemble it again, we recommend that you take your vehicle to an authorized HYUNDAI dealer and have the system checked for calibration.
- When you replace the windshield glass or LDWS camera, we recommend that you take your vehicle to an authorized HYUNDAI dealer and have the system checked for calibration.
- Do not spray water or any type of liquid near the camera. The system may become damaged.
- Do not attempt to repair the LDWS camera and do not remove any parts.

(Continued)

### (Continued)

- Do not place objects that reflect light on the dashboard while driving.
- Do not place any accessories near the inside rearview mirror.
- You may not hear a warning sound of LDWS because of the excessive audio sound.
- The operation of the LDWS may be affected by several factors including environmental conditions that affect the ability of the camera to detect the lanes in front of you. It is the responsibility of the driver to pay careful attention to the roadway and to maintain the vehicle in its intended lane at all times.

### LDWS operation

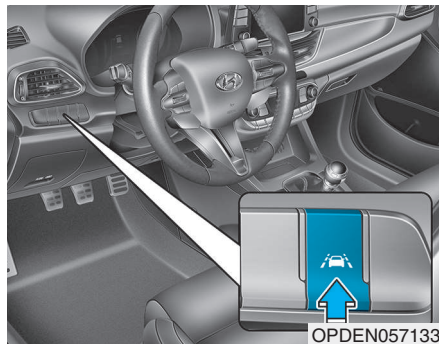

To activate/deactivate the LDWS:

With the ignition switch in the ON position, press the LDWS button located on the instrument panel on the lower left hand side of the driver.

The indicator in the cluster display will initially illuminate white. This indicates the LDWS is in the READY but NOT ENABLED state.



The color of indicator will change depending on the condition of LDWS.

- White : Sensor does not detect lane markers or vehicle speed is under 60 km/h (40mph).
- Green : Sensor detects lane markers.

### **i** Information

**If the indicator (white) is activated from the previous ignition cycle, the system will turn ON without any additional control. If you press the LDWS button again, the indicator on the cluster goes off.**

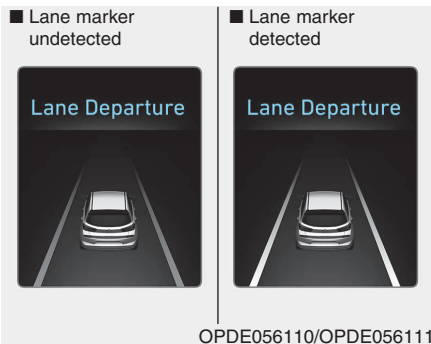

- To see the LDWS screen on the LCD display in the cluster, select Assist mode (A). For more details, refer to "LCD Display Modes" in chapter 3.
- If the system detects a lane marker, the color changes from gray to white.
- If the system detects the left lane marker, the left lane marker color will change from gray to white.
- If the system detects the right lane marker, the right lane marker color will change from gray to white.

- If your vehicle speed exceeds 60 km/h (40 mph) and the LDWS button is ON, the system is enabled. If your vehicle departs from the projected lane in front of you, the LDWS operates as follows:

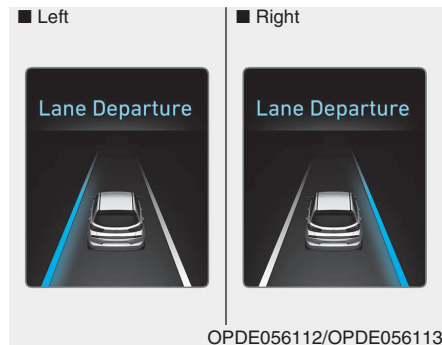

A visual warning appears on the cluster LCD display. Either the left lane marker or the right lane marker in the cluster LCD display will blink depending on which direction the vehicle is veering.

## Warning light and message

### Check LDWS

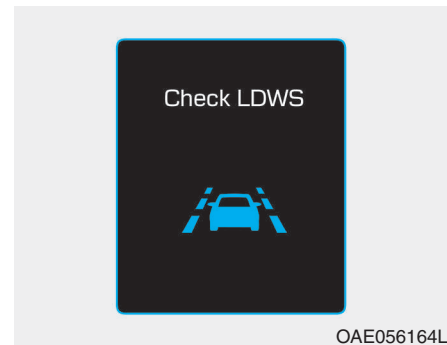

If there is a problem with the system a message will appear for a few seconds.

If the problem continues the LDWS failure indicator will illuminate.

### **LDWS failure indicator**



The LDWS failure indicator (yellow) will illuminate if the LDWS is not working properly. We recommend that you have your vehicle checked by an authorized HYUNDAI dealer.

#### **When there is a problem with the system, do one of the following:**

- Turn the system on after turning the vehicle off and on again.
- Check if the ignition switch is in the ON position.
- Check if the system is affected by the weather. (e.g. fog, heavy rain, etc.)
- Check if there is foreign matter on the camera lens.

If the problem is not solved, we recommend that you the system checked by an authorized HYUNDAI dealer.

### **Limitations of the system**

The LDWS may operate prematurely even if the vehicle does not depart from the intended lane, OR, the LDWS may not warn you if the vehicle leaves the intended lane under the following circumstances:

#### **When the lane and road conditions are poor**

- It is difficult to distinguish the lane marking from the road surface or the lane marking is faded or not clearly marked.
- It is difficult to distinguish the color of the lane marker from the road.
- There are markings on the road surface that look like a lane marker that is inadvertently being detected by the camera.
- The lane marker is merged or divided. (e.g. tollgate)
- The lane number increases or decreases or the lane marker are crossing complicatedly.
- There are more than two lane markers on the road in front of you.

- The lane marker is very thick or thin.
- The lanes ahead are not visible due to rain, snow, water on the road, damaged or stained road surface, or other factors.
- The shadow is on the lane marker by a median strip, trees, etc.
- The lanes are incomplete or the area is in a construction zone.
- There are crosswalk signs or other symbols on the road.
- The lane marker in a tunnel is stained with oil, etc.
- The lane suddenly disappears such as at the intersection.

#### **When external condition is intervened**

- The brightness outside changes suddenly such as when entering or exiting a tunnel, or when passing under a bridge.
- The brightness outside is too low such as when the headlamps are not on at night or the vehicle is going through a tunnel.

- There is a boundary structure in the roadway such as a concrete barrier, guardrail and reflector post that is inadvertently being detected by the camera.
- When light coming from a street light or an oncoming vehicle is reflected on a wet road surface such as a puddle in the road.
- The field of view in front is obstructed by sun glare.
- There is not enough distance between you and the vehicle in front to be able to detect the lane marker or the vehicle ahead is driving on the lane marker.
- Driving on a steep grade, over a hill, or when driving on a curved road.
- The adverse road conditions cause excessive vehicle vibrations while driving.
- The surrounding of the inside rear view mirror temperature is high due to direct sunlight, etc.

### **When front visibility is poor**

- The windshield or the LDWS camera lens is blocked with dirt or debris.
- The windshield glass is fogged up; a clear view of the road is obstructed.
- Placing objects on the dashboard, etc.
- The sensor cannot detect the lane because of fog, heavy rain or snow.

## DRIVER ATTENTION ALERT SYSTEM (DAA) (IF EQUIPPED)

The Driver Attention Alert (DAA) system displays the condition of the driver's fatigue level and inattentive driving practices.

### System setting and activation

#### System setting

- The Driver Attention Alert system is set to be in the OFF position, when your vehicle is first delivered to you from the factory.
- To turn ON the Driver Attention Alert system, turn on the engine, and then select 'User Settings → Driving Assist → Driver Attention Alert → Normal/Early' on the LCD display.
- The driver can select the Driver Attention Alert system mode.
  - Off : The Driver Attention Alert system is deactivated.
  - Normal : The Driver Attention Alert system alerts the driver of his/her fatigue level or inattentive driving practices.
  - Early : The Driver Attention Alert system alerts the driver of his/her fatigue level or inattentive driving practices faster than Normal mode.
- The set-up of the Driver Attention Alert system will be maintained, as selected, when the engine is restarted.

### Display of the driver's attention level

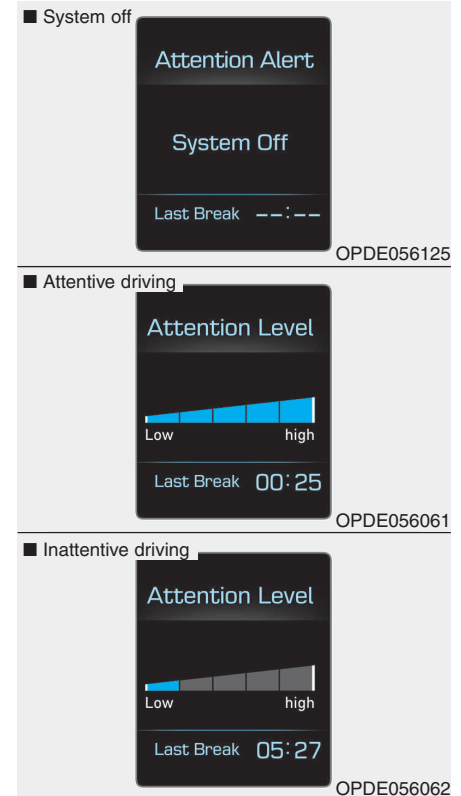

- The driver can monitor their driving conditions on the LCD display.

The DAA screen will appear when you select the Assist mode tab (A) on the LCD display if the system is activated. **(For more details, refer to "LCD Display Modes" in chapter 3.)**

- The driver's attention level is displayed on the scale of 1 to 5. The lower the number is, the more inattentive the driver is.
- The number decreases when the driver does not take a break for a certain period of time.
- The number increases when the driver attentively drives for a certain period of time.
- When the driver turns on the system while driving, it displays 'Last Break time' and level.

### Take a break



OPDE056063

- The "Consider taking a break" message appears on the LCD display and a warning sounds in order to suggest the driver to take a break, when the driver's attention level is below 1.
- The Driver Attention Alert system does not suggest the driver to take a break, when the total driving time is shorter than 10 minutes.

### Resetting the system

- The last break time is set to 00:00 and the driver's attention level is set to 5 (very attentive) when the driver resets the Driver Attention Alert system.
- The Driver Attention Alert system resets the last break time to 00:00 and the driver's attention level to 5 in the following situations.
  - The engine is turned OFF.
  - The driver unfastens the seat belt and then opens the driver's door.
  - The vehicle is stopped for more than 10 minutes.
- The Driver Attention Alert system operates again, when the driver restarts driving.

### System standby

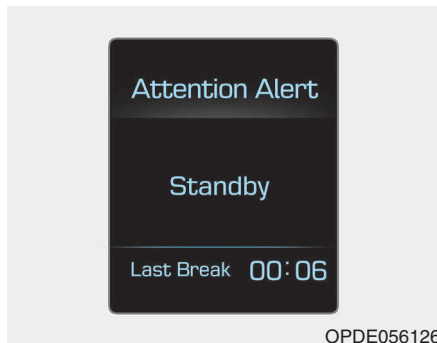

The Driver Attention Alert system enters the ready status and displays the 'Standby' screen in the following situations.

- The camera does not detect the lanes.
- Driving speed remains under 60 km/h (40 mph) or over 200 km/h (125 mph).

### System malfunction

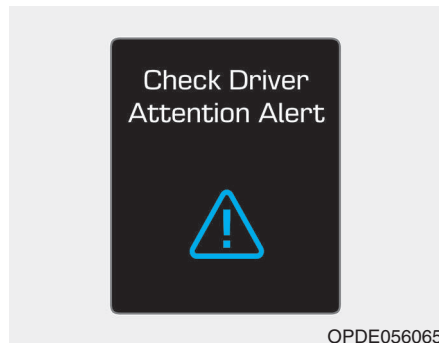

#### Check Driver Attention Alert

When the "Check Driver Attention Alert" warning message appears, the system is not working properly. In this case, we recommend that you have the vehicle inspected by an authorized HYUNDAI dealer.

### WARNING

- The Driver Attention Alert system is not a substitute for safe driving practices, but a convenience function only. It is the responsibility of the driver to always drive cautiously to prevent unexpected and sudden situations from occurring. Pay attention to the road conditions at all times.
- The system may suggest a break according to the driver's driving pattern or habits even if the driver doesn't feel fatigue.
- The driver, who feels fatigued, should take a break, even though there is no break suggestion by the Driver Attention Alert system.



## NOTICE

The Driver Attention Alert system utilizes the camera sensor on the front windshield for its operation. To keep the camera sensor in the best condition, you should observe the followings:

- NEVER install any accessories or stickers on the front windshield, nor tint the front windshield.
- NEVER locate any reflective objects (i.e. white paper, mirror) over the dashboard. Any light reflection may cause a malfunction of the Driver Attention Alert (DAA) system.
- Pay extreme caution to keep the camera sensor out of water.
- NEVER arbitrarily disassemble the camera assembly, nor apply any impact on the camera assembly. If you disassemble the camera and assemble it again, we recommend that you take your vehicle to an authorized HYUNDAI dealer and have the system checked for calibration.

## CAUTION

The Driver Attention Alert system may not properly operate with limited alerting in the following situations:

- The lane detection performance is limited. (For more details, refer to "Lane Keeping Assist System (LKAS)" or "Lane Departure Warning System (LDWS)" in this chapter.)
- The vehicle is violently driven or is abruptly turned for obstacle avoidance (e.g. construction area, other vehicles, fallen objects, bumpy road).
- Forward drivability of the vehicle is severely undermined (possibly due to wide variation in tire pressures, uneven tire wear-out, toe-in/toe-out alignment).
- The vehicle drives on a curvy road.
- The vehicle drives on a bumpy road.

(Continued)

(Continued)

- The vehicle drives through a windy area.
- The vehicle is controlled by the following driving assist systems:
  - Lane Keeping Assist System (LKAS)
  - Autonomous Emergency Braking (AEB) System

## CAUTION

Playing the vehicle audio system at high volume may offset the Driver Attention Alert system warning sounds.

## CRUISE CONTROL (IF EQUIPPED)

### Cruise Control operation

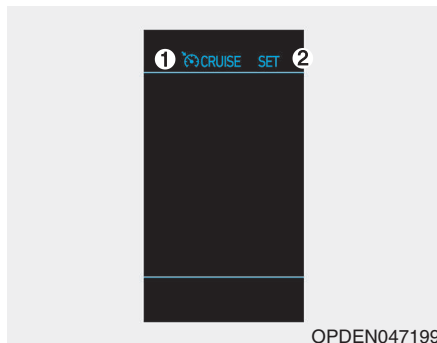



1. Cruise indicator
2. Set indicator

The Cruise Control system allows you to drive at speeds above 30 km/h (20 mph) without depressing the accelerator pedal.

### WARNING

Take the following precautions:

- Always set the vehicle speed under the speed limit in your country.
- If the Cruise Control is left on, ( CRUISE indicator light in the instrument cluster is illuminated) the Cruise Control can be activated unintentionally. Keep the Cruise Control system off ( CRUISE indicator light OFF) when the Cruise Control is not in use, to avoid inadvertently setting a speed.
- Use the Cruise Control system only when traveling on open highways in good weather.
- Do not use the Cruise Control when it may be unsafe to keep the vehicle at a constant speed:
  - When driving in heavy traffic or when traffic conditions make it difficult to drive at a constant speed

(Continued)

(Continued)

- When driving on rainy, icy, or snow-covered roads
- When driving on hilly or windy roads
- When driving in windy areas
- Do not use cruise control when towing a trailer.

## NOTICE

During cruise-speed driving of a manual transmission vehicle, do not shift into neutral without depressing the clutch pedal, since the engine will be overrevved. If this happens, depress the clutch pedal or press the cruise control ON / OFF button.

## **i** Information

- During normal cruise control operation, when the SET switch is activated or reactivated after applying the brakes, the cruise control will activate after approximately 3 seconds. This delay is normal.
- Before activating the cruise control function, the system will check to verify that the brake switch is operating normally. Depress the brake pedal at least once after turning ON the ignition or starting the vehicle.

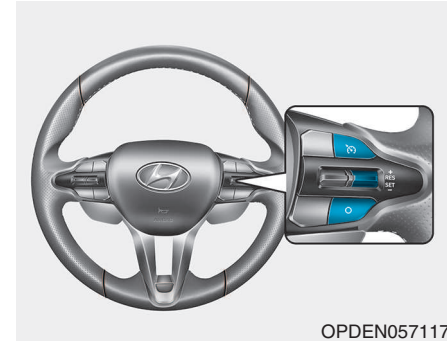

### Cruise control switch

O : Cancels cruise control operation.



 : Turns cruise control system on or off.

RES+ : Resumes or increases cruise control speed.

SET- : Sets or decreases cruise control speed.

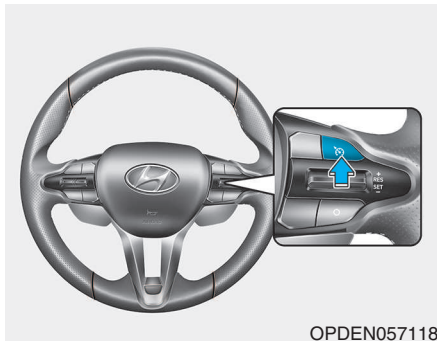
### To set Cruise Control speed



1. Press the  button on the steering wheel to turn the system on. The  CRUISE indicator will illuminate.
2. Accelerate to the desired speed, which must be more than 30 km/h (20 mph).

#### Information

For manual transmission vehicles, you should depress the brake pedal at least once to set the cruise control after starting the engine.

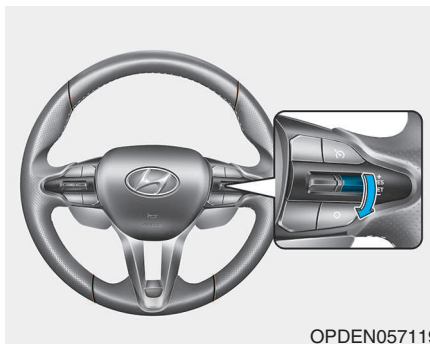

3. Push the toggle switch down (SET-), and release it. The SET indicator light will illuminate.
4. Release the accelerator pedal.

#### Information

On a steep slope, the vehicle may slightly slow down or speed up, while driving uphill or downhill.

### To increase Cruise Control speed

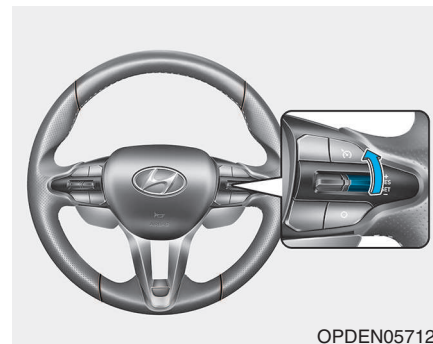

- Push the toggle switch up (RES+) and hold it, while monitoring the SET speed on the instrument cluster.

Release the toggle switch when the desired speed is shown and the vehicle will accelerate to that speed.

- Push the toggle switch up (RES+) and release it immediately. The cruising speed will increase 2.0 km/h (1.2 mph) each time the toggle switch is operated in this manner.
- Depress the accelerator pedal. When the vehicle attains the desired speed, push the toggle switch down (SET-).

### **To decrease Cruise Control speed**

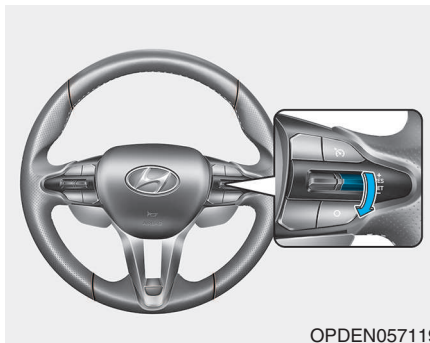

- Push the toggle switch down (SET-) and hold it. Your vehicle will gradually slow down. Release the toggle switch at the speed you want to maintain.
- Push the toggle switch down (SET-) and release it immediately. The cruising speed will decrease 2.0 km/h (1.2 mph) each time the toggle switch is operated in this manner.
- Lightly tap the brake pedal. When the vehicle attains the desired speed, push the toggle switch down (SET-).



### **To temporarily accelerate with the Cruise Control ON**

Depress the accelerator pedal. When you take your foot off the accelerator, the vehicle will return to the previously set speed.

If you push the toggle switch down (SET-) at the increased speed, the Cruise Control will maintain the increased speed.

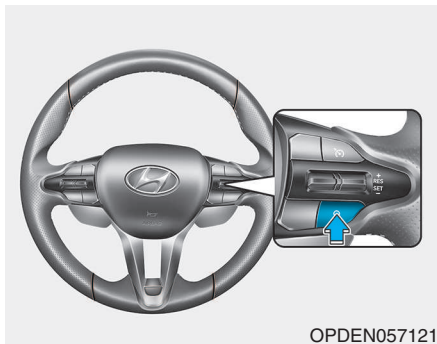

### ***Cruise Control will be canceled when:***



- Depressing the brake pedal.
- Depressing the clutch pedal.
- Pressing the **O** button located on the steering wheel.
- Pressing the  button. Both the  CRUISE indicator and the SET indicator will turn OFF.

- Decreasing the vehicle speed to less than approximately 30 km/h (20 mph).
- The ESC (Electronic Stability Control) is operating.

### ***i* Information**

Each of the above actions will cancel Cruise Control operation (the SET indicator light in the instrument cluster will go off), but only pressing the  button will turn the system off. If you wish to resume Cruise Control operation, push the toggle switch up (RES+) located on your steering wheel. You will return to your previously preset speed, unless the system was turned off using the  button.

### ***To resume preset Cruising speed***

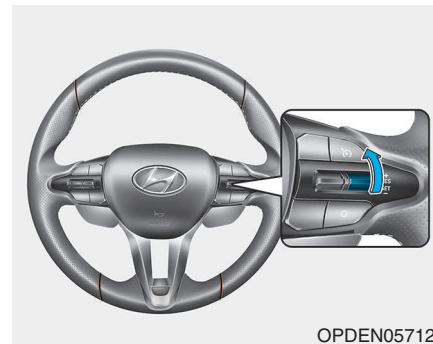

Push the toggle switch up (RES+). If the vehicle speed is over 30 km/h (20 mph), the vehicle will resume the preset speed.

## To turn Cruise Control off

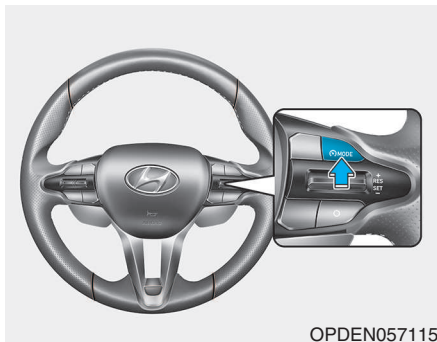

- Press the  button (the  CRUISE indicator light will go off).

## SPECIAL DRIVING CONDITIONS

### Hazardous driving conditions

When hazardous driving elements are encountered such as water, snow, ice, mud and sand, take the following precautions:

- Drive cautiously and maintain a longer braking distance.
- Avoid abrupt braking or steering.
- When your vehicle is stuck in snow, mud, or sand, use the second gear. Accelerate slowly to avoid unnecessary wheel spinning.
- Put sand, rock salt, tire chains or other non-slip materials under the wheels to provide additional traction while being stuck in ice, snow, or mud.

### Rocking the vehicle

If it is necessary to rock the vehicle to free it from snow, sand, or mud, first turn the steering wheel right and left to clear the area around your front wheels. Then, shift back and forth between R (Reverse) and a forward gear.

Try to avoid spinning the wheels, and do not race the engine.

To prevent transmission wear, wait until the wheels stop spinning before shifting gears. Release the accelerator pedal while shifting, and press lightly on the accelerator pedal while the transmission is in gear. Slowly spinning the wheels in forward and reverse directions causes a rocking motion that may free the vehicle.

### WARNING

**If the vehicle is stuck and excessive wheel spin occurs, the temperature in the tires can increase very quickly. If the tires become damaged, a tire blow out or tire explosion can occur. This condition is dangerous - you and others may be injured. Do not attempt this procedure if people or objects are anywhere near the vehicle.**

**If you attempt to free the vehicle, the vehicle can overheat quickly, possibly causing an engine compartment fire or other damage. Try to avoid spinning the wheels as much as possible to prevent overheating of either the tires or the engine. DO NOT allow the vehicle to spin the wheels above 56 km/h (35 mph).**



## **i** Information

The ESC system (if equipped) must be turned OFF before rocking the vehicle.

### **NOTICE**

**If you are still stuck after rocking the vehicle a few times, have the vehicle pulled out by a tow vehicle to avoid engine overheating, possible damage to the transmission, and tire damage. See "Towing" in chapter 6.**

## Smooth cornering

Avoid braking or gear changing in corners, especially when roads are wet. Ideally, corners should always be taken under gentle acceleration.

## Driving at night

Night driving presents more hazards than driving in the daylight. Here are some important tips to remember:

- Slow down and keep more distance between you and other vehicles, as it may be more difficult to see at night, especially in areas where there may not be any street lights.
- Adjust your mirrors to reduce the glare from other drivers' headlamps.
- Keep your headlamps clean and properly aimed. Dirty or improperly aimed headlamps will make it much more difficult to see at night.
- Avoid staring directly at the headlamps of oncoming vehicles. You could be temporarily blinded, and it will take several seconds for your eyes to readjust to the darkness.

## Driving in the rain

Rain and wet roads can make driving dangerous. Here are a few things to consider when driving in the rain or on slick pavement:

- Slow down and allow extra following distance. A heavy rainfall makes it harder to see and increases the distance needed to stop your vehicle.
- Turn OFF your Cruise Control. (if equipped)
- Replace your windshield wiper blades when they show signs of streaking or missing areas on the windshield.
- Be sure your tires have enough tread. If your tires do not have enough tread, making a quick stop on wet pavement can cause a skid and possibly lead to an accident. **See "Tire Tread" in chapter 7.**
- Turn on your headlamps to make it easier for others to see you.
- Driving too fast through large puddles can affect your brakes. If you must go through puddles, try to drive through them slowly.

- If you believe your brakes may be wet, apply them lightly while driving until normal braking operation returns.

### **Hydroplaning**

If the road is wet enough and you are going fast enough, your vehicle may have little or no contact with the road surface and actually ride on the water. The best advice is SLOW DOWN when the road is wet.

**The risk of hydroplaning increases as the depth of tire tread decreases, refer to "Tire Tread" in chapter 7.**

### **Driving in flooded areas**

Avoid driving through flooded areas unless you are sure the water is no higher than the bottom of the wheel hub. Drive through any water slowly. Allow adequate stopping distance because brake performance may be reduced.

After driving through water, dry the brakes by gently applying them several times while the vehicle is moving slowly.

### **Highway driving**

#### **Tires**

Adjust the tire inflation, as specified. Under-inflation may overheat or damage the tires.

Do not install worn-out or damaged tires, which may reduce traction or fail the braking operation.

#### ***i* Information**

**Never over-inflate your tires above the maximum inflation pressure, as specified on your tires.**

### ***Fuel, engine coolant and engine oil***

Driving at higher speeds on the highway consumes more fuel and is less efficient than driving at a slower, more moderate speed. Maintain a moderate speed in order to conserve fuel when driving on the highway.

Be sure to check both the engine coolant level and the engine oil before driving.

### ***Drive belt***

A loose or damaged drive belt may overheat the engine.

## WINTER DRIVING

The severe weather conditions of winter quickly wear out tires and cause other problems. To minimize winter driving problems, you should take the following suggestions:

### **i** Information

**Information for Snow Tires and Tire Chains in the national language (Bulgarian, Hungarian, Icelandic, Polish) is provided in the Appendix.**

### Snow or icy conditions

You need to keep sufficient distance between your vehicle and the vehicle in front of you.

Apply the brakes gently. Speeding, rapid acceleration, sudden brake applications, and sharp turns are potentially very hazardous practices. During deceleration, use engine braking to the fullest extent. Sudden brake applications on snowy or icy roads may cause skids to occur.

To drive your vehicle in deep snow, it may be necessary to use snow tires or to install tire chains on your tires.

Always carry emergency equipment. Some of the items you may want to carry include tire chains, tow straps or chains, a flashlight, emergency flares, sand, a shovel, jumper cables, a window scraper, gloves, ground cloth, coveralls, a blanket, etc.

### Snow tires

#### **⚠ WARNING**

**Snow tires should be equivalent in size and type to the vehicle's standard tires. Otherwise, the safety and handling of your vehicle may be adversely affected.**

We recommend you use snow tires when road temperature is below 7°C (45°F). Refer to the below chart, and mount the recommended snow tire for your vehicle.

Standard tire		Recommended snow tire	
Tire size	Wheel size	Tire size	Wheel size
225/40ZR18	7.5Jx18	225/40R18	7.5Jx18
235/35R19	8.0Jx19		

If you mount snow tires on your vehicle, make sure to use the same inflation pressure as the original tires. Mount snow tires on all four wheels to balance your vehicle's handling in all weather conditions. The traction provided by snow tires on dry roads may not be as high as your vehicle's original equipment tires. Check with the tire dealer for maximum speed recommendations.

### **i** Information

**Do not install studded tires without first checking local and municipal regulations for possible restrictions against their use.**

### **Tire chains**

Since the sidewalls of radial tires are thinner than other types of tires, they may be damaged by mounting some types of tire chains on them. Therefore, the use of snow tires is recommended instead of tire chains. Do not mount tire chains on vehicles equipped with aluminum wheels; if unavoidable use a wire type chain. If tire chains must be used, use genuine HYUNDAI parts and install the tire chain after reviewing the instructions provided with the tire chains. Damage to your vehicle caused by improper tire chain use is not covered by your vehicle manufacturer's warranty.

### **NOTICE**

**If your vehicle has 235/35R19 size tires, do not use tire chain; they can damage your vehicle (wheel, suspension and body).**

## **i** Information

- **Install tire chains on the front tires.** It should be noted that installing tire chains on the tires will provide a greater driving force, but will not prevent side skids.
- **Do not install studded tires without first checking local and municipal regulations for possible restrictions against their use.**

## Chain Installation



When installing tire chains, follow the manufacturer's instructions and mount them as tightly possible. Drive slowly (less than 30 km/h (20 mph)) with chains installed. If you hear the chains contacting the body or chassis, stop and tighten them. If they still make contact, slow down until the noise stops. Remove the tire chains as soon as you begin driving on cleared roads.

When mounting snow chains, park the vehicle on level ground away from traffic. Turn on the vehicle Hazard Warning Flasher and place a triangular emergency warning device

behind the vehicle (if available). Always place the vehicle in P (Park), apply the parking brake and turn off the engine before installing snow chains.

### **⚠ WARNING**

The use of tire chains may adversely affect vehicle handling:

- **Drive less than 30 km/h (20 mph) or the chain manufacturer's recommended speed limit, whichever is lower.**
- **Drive carefully and avoid bumps, holes, sharp turns, and other road hazards, which may cause the vehicle to bounce.**
- **Avoid sharp turns or locked wheel braking.**

### NOTICE

#### When using tire chains:

- **Wrong size chains or improperly installed chains can damage your vehicle's brake lines, suspension, body and wheels.**
- **Use SAE "S" class or wire chains.**
- **If you hear noise caused by chains contacting the body, retighten the chain to prevent contact with the vehicle body.**
- **To prevent body damage, retighten the chains after driving 0.5~1.0 km (0.3~0.6 miles).**
- **Do not use tire chains on vehicles equipped with aluminum wheels. If unavoidable, use a wire type chain.**
- **Use wire chains less than 12 mm (0.47 in) wide to prevent damage to the chain's connection.**

### Winter Precautions

#### Use high quality ethylene glycol coolant

Your vehicle is delivered with high quality ethylene glycol coolant in the cooling system. It is the only type of coolant that should be used because it helps prevent corrosion in the cooling system, lubricates the water pump and prevents freezing. Be sure to replace or replenish your coolant in accordance with the maintenance schedule in chapter 7. Before winter, have your coolant tested to assure that its freezing point is sufficient for the temperatures anticipated during the winter.

#### Check battery and cables

Winter temperatures affect battery performance. **Inspect the battery and cables, as specified in the chapter 7.** The battery charging level can be checked by an authorized HYUNDAI dealer or in a service station.

#### Change to "winter weight" oil if necessary

In some regions during winter, it is recommended to use the "winter weight" oil with lower viscosity. For further information, refer to the chapter 8. When you are not sure about a type of winter weight oil, consult an authorized HYUNDAI dealer.

### **Check spark plugs and ignition system**

**Inspect the spark plugs, as specified in the chapter 7.** If necessary, replace them. Also check all ignition wirings and components for any cracks, wear-out, and damage.

### **To prevent locks from freezing**

To prevent the locks from being frozen, spray approved de-icing fluid or glycerin into key holes. When a lock opening is already covered with ice, spray approved de-icing fluid over the ice to remove it. When an internal part of a lock freezes, try to thaw it with a heated key. Carefully use the heated key to avoid an injury.

### **Use approved window washer anti-freeze solution in system**

To prevent the window washer from being frozen, add authorized window washer anti-freeze solution, as specified on the window washer container. Window washer anti-freeze solution is available from an authorized HYUNDAI dealer, and most vehicle accessory outlets. Do not use engine coolant or other types of anti-freeze solution, to prevent any damage to the vehicle paint.

### **Do not let your parking brake freeze**

Under some conditions your parking brake can freeze in the engaged position. This is most likely to happen when there is an accumulation of snow or ice around or near the rear brakes or if the brakes are wet. When there is the risk that your parking brake may freeze, temporarily apply it with the shift lever in 1st gear when the vehicle is parked on a uphill and in R (Reverse) on a downhill. Also, block the rear wheels in advance, so the vehicle may not roll. Then, release the parking brake.

### **Do not let ice and snow accumulate underneath**

Under some conditions, snow and ice can build up under the fenders and interfere with the steering. When driving in such conditions during the severe winter, you should check underneath the vehicle on a regular basis, to ensure that the front wheels and the steering components is unblocked.

### TRAILER TOWING (FOR EUROPE)

If you are considering to tow with your vehicle, you should first your country's legal requirements. As laws vary the requirements for towing trailers, cars, or other types of vehicles or apparatus may differ. Ask an authorized HYUNDAI dealer for further details before towing.

Remember that trailering is different than just driving your vehicle by itself. Trailering means changes in handling, durability, and fuel economy. Successful, safe trailering requires correct equipment, and it has to be used properly. Damage to your vehicle caused by improper trailer towing is not covered by your vehicle manufacturer's warranty.

This section contains many time-tested, important trailering tips and safety rules. Many of these are important for your safety and that of your passengers. Please read this section carefully before you pull a trailer.

#### WARNING

Take the following precautions:

- **If you don't use the correct equipment and/or drive improperly, you can lose control of the vehicle when you are pulling a trailer. For example, if the trailer is too heavy, the braking performance may be reduced. You and your passengers could be seriously or fatally injured. Pull a trailer only if you have followed all the steps in this section.**
- **Before towing, make sure the total trailer weight, GCW (Gross Combination Weight), GVW (Gross Vehicle Weight), GAW (Gross Axle Weight) and trailer tongue load are all within the limits.**
- **When you tow a trailer, make sure to turn off the ISG system.**

#### Information - For Europe

- **The technically permissible maximum load on the rear axle(s) may be exceeded by not more than 15 % and the technically permissible maximum laden mass of the vehicle may be exceeded by not more than 10% or 100 kg (220.4 lbs), whichever value is lower. In this case, do not exceed 100 km/h (62.1 mph) for vehicle of category M1 or 80 km/h (49.7 mph) for vehicle of category N1.**
- **When a vehicle of category M1 is towing a trailer, the additional load imposed at the trailer coupling device may cause the tire maximum load ratings to be exceeded, but not by more than 15%. In this case, do not exceed 100 km/h (62.1 mph) and increase the tire inflation pressure by at least 0.2 bar.**



## If you decide to pull a trailer?

Here are some important points if you decide to pull a trailer:

- Consider using a sway control. You can ask a trailer hitch dealer about sway control.
- Do not do any towing with your vehicle during its first 2,000 km (1,200 miles) in order to allow the engine to properly break in. Failure to heed this caution may result in serious engine or transmission damage.
- When towing a trailer, be sure to consult an authorized HYUNDAI dealer for further information on additional requirements such as a towing kit, etc.
- Always drive your vehicle at a moderate speed (less than 100 km/h (60 mph)) or posted towing speed limit.
- On a long uphill grade, do not exceed 70 km/h (45 mph) or the posted towing speed limit, whichever is lower.
- Carefully observe the weight and load limits provided in the following pages.

## Trailer weight

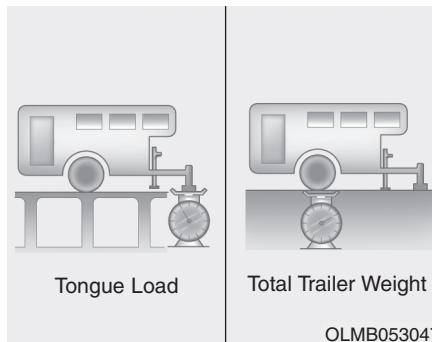

What is the maximum safe weight of a trailer? It should never weigh more than the maximum trailer weight with trailer brakes. But even that can be too heavy. It depends on how you plan to use your trailer. For example, speed, altitude, road grades, outside temperature and how often your vehicle is used to pull a trailer are all important. The ideal trailer weight can also depend on any special equipment that you have on your vehicle.

## Tongue load

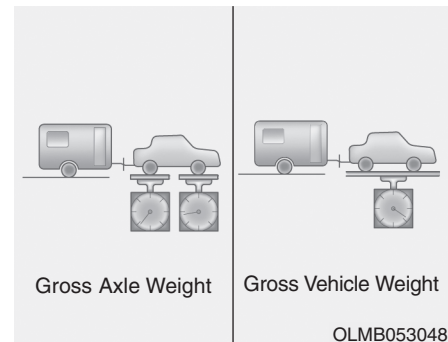

The tongue load is an important weight to measure because it affects the total Gross Vehicle Weight (GVW) of your vehicle. The trailer tongue should weigh a maximum of 10% of the total loaded trailer weight, within the limits of the maximum trailer tongue load permissible.

After you've loaded your trailer, weigh the trailer and then the tongue, separately, to see if the weights are proper. If they aren't, you may be able to correct them simply by moving some items around in the trailer.

**⚠ WARNING**

Take the following precautions:

- Never load a trailer with more weight in the rear than in the front. The front should be loaded with approximately 60% of the total trailer load; the rear should be loaded with approximately 40% of the total trailer load.
- Never exceed the maximum weight limits of the trailer or trailer towing equipment. Improper loading can result in damage to your vehicle and/or personal injury. Check weights and loading at a commercial scale or highway patrol office equipped with scales.

**i Information**

With increasing altitude the engine performance decreases. From 1,000 m above sea level and for every 1,000 m thereafter 10% of vehicle/trailer weight (trailer weight + gross vehicle weight) must be deducted.

**Reference weight and distance when towing a trailer (for Europe)**

Item		Theta 2.0 T-GDI
Maximum trailer weight kg (lbs.)	With brake system	1600 (3527)
	Without brake system	700 (1543)
Maximum permissible static vertical load on the coupling device kg (lbs.)		75 (165)
Recommended distance from rear wheel center to coupling point mm (inch)		880 (34.6)

## Trailer towing equipment

### Hitches

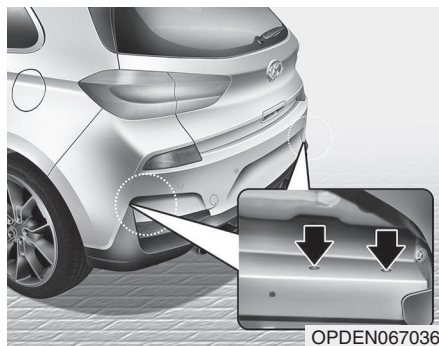

#### **i** Information

The mounting hole for hitches are located on both sides of the underbody behind the rear tires.

It's important to have the correct hitch equipment. Crosswinds, large trucks going by, and rough roads are a few reasons why you'll need the right hitch. Here are some rules to follow:

- Do you have to make any holes in the body of your vehicle when you install a trailer hitch? If you do, then be sure to seal the holes later when you remove the hitch. If you don't seal them, carbon monoxide (CO) from your exhaust can get into your vehicle, as well as dirt and water.
- The bumpers on your vehicle are not intended for hitches. Do not attach rental hitches or other bumper-type hitches to them. Use only a frame-mounted hitch that does not attach to the bumper.
- A HYUNDAI trailer hitch accessory is available at an authorized HYUNDAI dealer.

### **Safety chains**

You should always attach chains between your vehicle and your trailer.

Instructions about safety chains may be provided by the hitch manufacturer or trailer manufacturer. Follow the manufacturer's recommendation for attaching safety chains. Always leave just enough slack so you can turn with your trailer. And, never allow safety chains to drag on the ground.

### **Trailer brakes**

If your trailer is equipped with a braking system, make sure it conforms to your country's regulations and that it is properly installed and operating correctly.

If your trailer weighs more than the maximum trailer weight without trailer brakes loaded, then it needs its own brakes and they must be adequate. Be sure to read and follow the instructions for the trailer brakes so you'll be able to install, adjust and maintain them properly. Be sure not to modify your vehicle's brake system.

#### **WARNING**

**Do not use a trailer with its own brakes unless you are absolutely certain that you have properly set up the brake system. This is not a task for amateurs. Use an experienced, competent trailer shop for this work.**

### **Driving with a trailer**

Towing a trailer requires a certain amount of experience. Before setting out for the open road, you must get to know your trailer. Acquaint yourself with the feel of handling and braking with the added weight of the trailer. And always keep in mind that the vehicle you are driving is now longer and not nearly as responsive as your vehicle is by itself.

Before you start, check the trailer hitch and platform, safety chains, electrical connector(s), lights, tires and brakes.

During your trip, occasionally check to be sure that the load is secure, and that the lights and trailer brakes are still working.

### **Distance**

Stay at least twice as far behind the vehicle ahead as you would when driving your vehicle without a trailer. This can help you avoid situations that require heavy braking and sudden turns.

### **Passing**

You will need more passing distance up ahead when you're towing a trailer. And, because of the increased vehicle length, you'll need to go much farther beyond the passed vehicle before you can return to your lane.

### **Backing up**

Hold the bottom of the steering wheel with one hand. Then, to move the trailer to the left, move your hand to the left. To move the trailer to the right, move your hand to the right. Always back up slowly and, if possible, have someone guide you.

### **Making turns**

When you're turning with a trailer, make wider turns than normal. Do this so your trailer won't strike soft shoulders, curbs, road signs, trees, or other objects. Avoid jerky or sudden maneuvers. Signal well in advance.

### **Turn signals**

When you tow a trailer, your vehicle has to have a different turn signal flasher and extra wiring. The green arrows on your instrument panel will flash whenever you signal a turn or lane change. Properly connected, the trailer lights will also flash to alert other drivers you're about to turn, change lanes, or stop.

When towing a trailer, the green arrows on your instrument panel will flash for turns even if the bulbs on the trailer are burned out. Thus, you may think drivers behind you are seeing your signals when, in fact, they are not. It's important to check occasionally to be sure the trailer bulbs are still working. You must also check the lights every time you disconnect and then reconnect the wires.

#### **⚠ WARNING**

**Do not connect a trailer lighting system directly to your vehicle's lighting system. Use an approved trailer wiring harness. Failure to do so could result in damage to the vehicle electrical system and/or personal injury. Consult an authorized HYUNDAI dealer for assistance.**

### **Driving on hills**

Reduce speed and shift to a lower gear before you start down a long or steep downgrade. If you don't shift down, you might have to use your brakes so much that they would get overheated and may not operate efficiently.

On a long uphill grade, shift down and reduce your speed to around 70 km/h (45 mph) to reduce the possibility of engine and transmission overheating.

### **NOTICE**

To prevent engine and/or transmission overheating:

- When towing a trailer on steep grades (in excess of 6%) pay close attention to the engine coolant temperature gauge to ensure the engine does not overheat. If the needle of the coolant temperature gauge moves towards "130", pull over and stop as soon as it is safe to do so, and allow the engine to idle until it cools down. You may proceed once the engine has cooled sufficiently.
- If you tow a trailer with the maximum gross vehicle weight and maximum trailer weight, it can cause the engine or transmission to overheat. When driving in such conditions, allow the engine to idle until it cools down. You may proceed once the engine or transmission has cooled sufficiently.

(Continued)

(Continued)

- When towing a trailer, your vehicle speed may be much slower than the general flow of traffic, especially when climbing an uphill grade. Use the right hand lane when towing a trailer on an uphill grade. Choose your vehicle speed according to the maximum posted speed limit for vehicles with trailers, the steepness of the grade, and your trailer weight.

### **Parking on hills**

Generally, if you have a trailer attached to your vehicle, you should not park your vehicle on a hill.

However, if you ever have to park your trailer on a hill, here's how to do it:

1. Pull the vehicle into the parking space.  
Turn the steering wheel in the direction of the curb (right if headed down hill, left if headed up hill).
2. Shift the vehicle to neutral.
3. Set the parking brake and shut off the vehicle.
4. Place wheel chocks under the trailer wheels on the down hill side of the wheels.
5. Start the vehicle, hold the brakes, shift to neutral, release the parking brake and slowly release the brakes until the trailer chocks absorb the load.
6. Reapply the brakes and parking brakes.

7. Move the shift lever to 1st gear when the vehicle is parked on a uphill grade and in R (Reverse) on a downhill.
8. Shut off the vehicle and release the vehicle brakes but leave the parking brake set.

 **WARNING**

**To prevent serious or fatal injury:**

- **Do not get out of the vehicle without the parking brake firmly set. If you have left the engine running, the vehicle can move suddenly. You and others could be seriously or fatally injured.**
- **Do not apply the accelerator pedal to hold the vehicle on an uphill.**

***Ready to leave after parking on a hill***

1. With the shift lever in neutral, apply your brakes and hold the brake pedal down while you:
  - Start your engine;
  - Shift into gear; and
  - Release the parking brake.
2. Slowly remove your foot from the brake pedal.
3. Drive slowly until the trailer is clear of the chocks.
4. Stop and have someone pick up and store the chocks.

**Maintenance when towing a trailer**

Your vehicle will need service more often when you regularly pull a trailer. Important items to pay particular attention to include engine oil, automatic transmission fluid, axle lubricant and cooling system fluid. Brake condition is another important item to frequently check. If you're trailering, it's a good idea to review these items before you start your trip. Don't forget to also maintain your trailer and hitch. Follow the maintenance schedule that accompanied your trailer and check it periodically. Preferably, conduct the check at the start of each day's driving. Most importantly, all hitch nuts and bolts should be tight.

### **NOTICE**

To prevent vehicle damage:

- Due to higher load during trailer usage, overheating might occur on hot days or during uphill driving. If the coolant gauge indicates over-heating, switch off the air conditioner and stop the vehicle in a safe area to cool down the engine.
- Do not switch off the engine while the coolant gauge indicates over-heating.  
(Keep the engine idle to cool down the engine)
- If your vehicle is not equipped with an air conditioner, you should install a condenser fan to improve engine performance when towing a trailer.



## VEHICLE WEIGHT

Two labels on your driver's door sill show how much weight your vehicle was designed to carry: the Tire and Loading Information Label and the Certification Label.

Before loading your vehicle, familiarize yourself with the following terms for determining your vehicle's weight ratings, from the vehicle's specifications and the Certification Label:

### Base Curb Weight

This is the weight of the vehicle including a full tank of fuel and all standard equipment. It does not include passengers, cargo, or optional equipment.

### Vehicle Curb Weight

This is the weight of your new vehicle when you picked it up from your dealer plus any aftermarket equipment.

### Cargo Weight

This figure includes all weight added to the Base Curb Weight, including cargo and optional equipment.

### GAW (Gross Axle Weight)

This is the total weight placed on each axle (front and rear) - including vehicle curb weight and all payload.

### GAWR (Gross Axle Weight Rating)

This is the maximum allowable weight that can be carried by a single axle (front or rear). These numbers are shown on the Certification Label. The total load on each axle must never exceed its GAWR.

### GVW (Gross Vehicle Weight)

This is the Base Curb Weight plus actual Cargo Weight plus passengers.

### GVWR (Gross Vehicle Weight Rating)

This is the maximum allowable weight of the fully loaded vehicle (including all options, equipment, passengers and cargo). The GVWR is shown on the Certification Label located on the driver's door sill.

## Overloading

### WARNING

The Gross Axle Weight Rating (GAWR) and the Gross Vehicle Weight Rating (GVWR) for your vehicle are on the Certification Label attached to the driver's (or front passenger's) door. Exceeding these ratings can cause an accident or vehicle damage. You can calculate the weight of your load by weighing the items (and people) before putting them in the vehicle. Be careful not to overload your vehicle.

# What to do in an emergency

Hazard warning flasher .....	6-2
<b>In case of an emergency while driving .....</b>	<b>6-2</b>
If the engine stalls while driving .....	6-2
If the engine stalls at a crossroad or crossing .....	6-2
If you have a flat tire while driving .....	6-3
<b>If the engine will not start .....</b>	<b>6-3</b>
If the engine doesn't turn over or turns over slowly .....	6-3
If the engine turns over normally but doesn't start .....	6-4
<b>Jump starting .....</b>	<b>6-4</b>
<b>If the engine overheats .....</b>	<b>6-7</b>
<b>Tire Pressure Monitoring System (TPMS).....</b>	<b>6-8</b>
Check tire pressure.....	6-8
Tire pressure monitoring system .....	6-9
Low tire pressure telltale .....	6-10
Low tire pressure position telltale and tire pressure telltale .....	6-10
TPMS (Tire Pressure Monitoring System) malfunction indicator .....	6-12
Changing a tire with TPMS.....	6-12
<b>If you have a flat tire (with spare tire).....</b>	<b>6-15</b>
Jack and tools .....	6-15
Changing tires .....	6-16
Jack label.....	6-21
EC Declaration of conformity for Jack.....	6-22
<b>If you have a flat tire (with tire mobility kit)</b>	
- <b>Type A .....</b>	<b>6-23</b>
Introduction .....	6-23
Notes on the safe use of the Tire Mobility Kit.....	6-24
Components of the Tire Mobility Kit .....	6-25
Using the Tire Mobility Kit.....	6-26
Checking the tire inflation pressure .....	6-28
- <b>If you have a flat tire (with tire mobility kit)</b>	
- <b>Type B .....</b>	<b>6-30</b>
Introduction .....	6-30
Notes on the safe use of the Tire Mobility Kit.....	6-31
Components of the Tire Mobility Kit .....	6-32
Using the Tire Mobility Kit.....	6-33
Checking the tire inflation pressure .....	6-35
<b>Towing .....</b>	<b>6-37</b>
Towing service .....	6-37
Removable towing hook .....	6-38
Emergency towing .....	6-39
<b>Emergency commodity .....</b>	<b>6-41</b>
Fire extinguisher .....	6-41
First aid kit.....	6-41
Triangle reflector .....	6-41
Tire pressure gauge .....	6-41

## HAZARD WARNING FLASHER

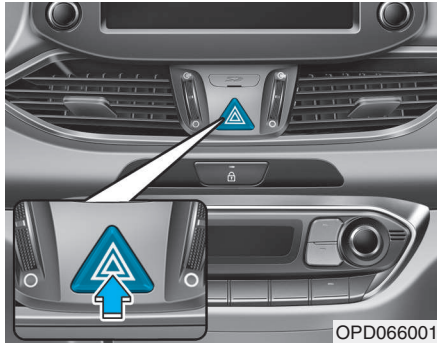

The hazard warning flasher serves as a warning to other drivers to exercise extreme caution when approaching, overtaking, or passing your vehicle.

It should be used whenever emergency repairs are being made or when the vehicle is stopped near the edge of a roadway.

To turn the hazard warning flasher on or off, press the hazard warning flasher button with the ignition switch in any position. The button is located in the center fascia panel. All turn signal lights will flash simultaneously.

- The hazard warning flasher operates whether your vehicle is running or not.
- The turn signals do not work when the hazard flasher is on.

## IN CASE OF AN EMERGENCY WHILE DRIVING

### If the engine stalls while driving

- Reduce your speed gradually, keeping a straight line. Move cautiously off the road to a safe place.
- Turn on your hazard warning flasher.
- Try to start the engine again. If your vehicle will not start, we recommend that you contact an authorized HYUNDAI dealer.

### If the engine stalls at a cross-road or crossing

If the engine stalls at a crossroads or crossing, if safe to do so, move the shift lever to the N (Neutral) position and then push the vehicle to a safe location.

### If you have a flat tire while driving

If a tire goes flat while you are driving:

- Take your foot off the accelerator pedal and let the vehicle slow down while driving straight ahead. Do not apply the brakes immediately or attempt to pull off the road as this may cause loss of vehicle control resulting in an accident. When the vehicle has slowed to such a speed that it is safe to do so, brake carefully and pull off the road. Drive off the road as far as possible and park on firm, level ground. If you are on a divided highway, do not park in the median area between the two traffic lanes.

- When the vehicle is stopped, press the hazard warning flasher button, move the shift lever into neutral, apply the parking brake, and place the ignition switch in the LOCK/OFF position.
- Have all passengers get out of the vehicle. Be sure they all get out on the side of the vehicle that is away from traffic.
- When changing a flat tire, follow the instructions provided later in this chapter.

### IF THE ENGINE WILL NOT START

#### If the engine doesn't turn over or turns over slowly

- Be sure that you have fully depressed the clutch pedal.
- Check the battery connections to be sure they are clean and tight.
- Turn on the interior light. If the light dims or goes out when you operate the starter, the battery is drained.

Do not push or pull the vehicle to start it. This could cause damage to your vehicle. **See instructions for "Jump Starting" provided in this chapter.**



#### CAUTION

**Push or pull starting the vehicle may cause the catalytic converter to overload which can lead to damage to the emission control system.**

### If the engine turns over normally but doesn't start

- Check the fuel level and add fuel if necessary.

If the engine still does not start, we recommend that you call an authorized HYUNDAI dealer for assistance.

## JUMP STARTING

Jump starting can be dangerous if done incorrectly. Follow the jump starting procedure in this section to avoid serious injury or damage to your vehicle. If in doubt about how to properly jump start your vehicle, we strongly recommend that you have a service technician or towing service do it for you.

### WARNING

To prevent **SERIOUS INJURY** or **DEATH** to you or bystanders, always follow these precautions when working near or handling the battery:



Always read and follow instructions carefully when handling a battery.



Wear eye protection designed to protect the eyes from acid splashes.



Keep all flames, sparks, or smoking materials away from the battery.

(Continued)

(Continued)



Hydrogen is always present in battery cells, is highly combustible, and may explode if ignited.



Keep batteries out of reach of children.



Batteries contain sulfuric acid which is highly corrosive. Do not allow acid to contact your eyes, skin or clothing.

If acid gets into your eyes, flush your eyes with clean water for at least 15 minutes and get immediate medical attention. If acid gets on your skin, thoroughly wash the area. If you feel pain or a burning sensation, get medical attention immediately.

(Continued)

(Continued)

- When lifting a plastic-cased battery, excessive pressure on the case may cause battery acid to leak. Lift with a battery carrier or with your hands on opposite corners.
- Do not attempt to jump start your vehicle if your battery is frozen.
- NEVER attempt to recharge the battery when the vehicle's battery cables are connected to the battery.
- The electrical ignition system works with high voltage. NEVER touch these components with the engine running or when the ignition switch is in the ON position.
- Do not allow the (+) and (-) jumper cables to touch. It may cause sparks.
- The battery may rupture or explode when you jump start with a low or frozen battery.

#### NOTICE

To prevent damage to your vehicle:

- Only use a 12-volt power supply (battery or jumper system) to jump start your vehicle.
- Do not attempt to jump start your vehicle by push-starting.

#### Information



An inappropriately disposed battery can be harmful to the environment and human health. Dispose the battery according to your local law(s) or regulations.

#### *Jump starting procedure*

1. Position the vehicles close enough that the jumper cables will reach, but do not allow the vehicles to touch.
2. Avoid fans or any moving parts in the engine compartment at all times, even when the vehicles are turned off.
3. Turn off all electrical devices such as radios, lights, air conditioning, etc. Put the vehicles in neutral, and set the parking brakes. Turn both vehicles OFF.

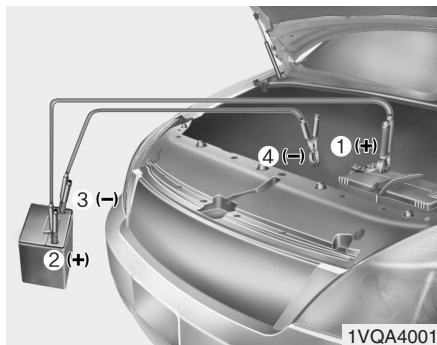

4. Connect the jumper cables in the exact sequence shown in the illustration. First connect one jumper cable to the red, positive (+) jumper terminal of your vehicle (1).
5. Connect the other end of the jumper cable to the red, positive (+) battery/jumper terminal of the assisting vehicle (2).
6. Connect the second jumper cable to the black, negative (-) battery/chassis ground of the assisting vehicle (3).

7. Connect the other end of the second jumper cable to the black, negative (-) chassis ground of your vehicle (4).

Do not allow the jumper cables to contact anything except the correct battery or jumper terminals or the correct ground. Do not lean over the battery when making connections.

8. Start the engine of the assisting vehicle and let it run at approximately 2,000 rpm for a few minutes. Then start your vehicle.

If your vehicle will not start after a few attempts, it probably requires servicing. In this event please seek qualified assistance. If the cause of your battery discharging is not apparent, have your vehicle checked by an authorized HYUNDAI dealer.

Disconnect the jumper cables in the exact reverse order you connected them:

1. Disconnect the jumper cable from the black, negative (-) chassis ground of your vehicle (4).
2. Disconnect the other end of the jumper cable from the black, negative (-) battery/chassis ground of the assisting vehicle (3).
3. Disconnect the second jumper cable from the red, positive (+) battery/jumper terminal of the assisting vehicle (2).
4. Disconnect the other end of the jumper cable from the red, positive (+) jumper terminal of your vehicle (1).

## IF THE ENGINE OVERHEATS

If your temperature gauge indicates overheating, you experience a loss of power, or hear loud pinging or knocking, the engine may be overheating. If this happens, you should:

1. Pull off the road and stop as soon as it is safe to do so.
2. Place the shift lever in neutral and set the parking brake. If the air conditioning is ON, turn it OFF.
3. If engine coolant is running out under the vehicle or steam is coming out from the hood, stop the engine. Do not open the hood until the coolant has stopped running or the steaming has stopped. If there is no visible loss of engine coolant and no steam, leave the engine running and check to be sure the engine cooling fan is operating. If the fan is not running, turn the engine off.

### ⚠ WARNING

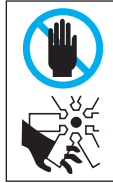

**While the engine is running, keep hands, clothing and tools away from the moving parts such as the cooling fan and drive belt to prevent serious injury.**

4. Check for coolant leaking from the radiator, hoses or under the vehicle. (If the air conditioning had been in use, it is normal for cold water to be draining from it when you stop.)
5. If engine coolant is leaking out, stop the engine immediately and we recommend that you call an authorized HYUNDAI dealer for assistance.

### ⚠ WARNING



**NEVER** remove the radiator cap or the drain plug while the engine and radiator are hot. Hot coolant and steam may blow out under pressure, causing serious injury. Turn the engine off and wait until the engine cools down. Use extreme care when removing the radiator cap. Wrap a thick towel around it, and turn it counterclockwise slowly to the first stop. Step back while the pressure is released from the cooling system. When you are sure all the pressure has been released, press down on the cap, using a thick towel, and continue turning counterclockwise to remove it.



- If you cannot find the cause of the overheating, wait until the engine temperature has returned to normal. Then, if coolant has been lost, carefully add coolant to the reservoir to bring the fluid level in the reservoir up to the halfway mark.
- Proceed with caution, keeping alert for further signs of overheating. If overheating happens again, we recommend that you call an authorized HYUNDAI dealer for assistance.

### CAUTION

- **Serious loss of coolant indicates a leak in the cooling system and we recommend the system be checked by an authorized HYUNDAI dealer.**
- **When the engine overheats from low engine coolant, suddenly adding engine coolant may cause cracks in the engine. To prevent damage, add engine coolant slowly in small quantities.**

## TIRE PRESSURE MONITORING SYSTEM (TPMS) (IF EQUIPPED)

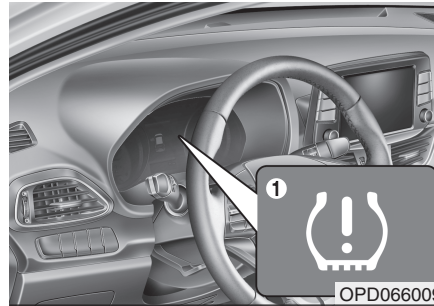

- (1) Low Tire Pressure Telltale/ TPMS Malfunction Indicator
- (2) Low tire pressure position telltale and tire pressure telltale (Shown on the LCD display)

### Check tire pressure



- You can check the tire pressure in the Assist mode on the cluster.

### Refer to the "LCD Display Modes" in chapter 3.

- Tire pressure is displayed after a few minutes of driving after initial engine start up.
- If tire pressure is not displayed when the vehicle is stopped, "Drive to display" message will appear. After driving, check the tire pressure.

- The displayed tire pressure values may differ from those measured with a tire pressure gauge.
- You can change the tire pressure unit in the User Settings mode on the instrument cluster.
  - psi, kpa, bar (**Refer to "LCD Modes" in chapter 3**).

### Tire pressure monitoring system

#### WARNING

**Over-inflation or under-inflation can reduce tire life, adversely affect vehicle handling, and lead to sudden tire failure that may cause loss of vehicle control resulting in an accident.**

Each tire, including the spare (if provided), should be checked monthly when cold and inflated to the inflation pressure recommended by the vehicle manufacturer on the vehicle placard or tire inflation pressure label. (If your vehicle has tires of a different size than the size indicated on the vehicle placard or tire inflation pressure label, you should determine the proper tire inflation pressure for those tires.)

As an added safety feature, your vehicle has been equipped with a tire pressure monitoring system (TPMS) that illuminates a low tire pressure telltale when one or more of your tires is significantly under-inflated. Accordingly, when the low tire pressure telltale illuminates, you should stop and check your tires as soon as possible, and inflate them to the proper pressure. Driving on a significantly under-inflated tire causes the tire to overheat and can lead to tire failure. Under-inflation also reduces fuel efficiency and tire tread life, and may affect the vehicle's handling and stopping ability.

Please note that the TPMS is not a substitute for proper tire maintenance, and it is the driver's responsibility to maintain correct tire pressure, even if under-inflation has not reached the level to trigger illumination of the TPMS low tire pressure telltale.

Your vehicle has also been equipped with a TPMS malfunction indicator to indicate when the system is not operating properly. The TPMS malfunction indicator is combined with the low tire pressure telltale. When the system detects a malfunction, the telltale will flash for approximately one minute and then remain continuously illuminated. This sequence will continue upon subsequent vehicle start-ups as long as the malfunction exists. When the malfunction indicator is illuminated, the system may not be able to detect or signal low tire pressure as intended.

TPMS malfunctions may occur for a variety of reasons, including the installation of replacement or alternate tires or wheels on the vehicle that prevent the TPMS from functioning properly. Always check the TPMS malfunction telltale after replacing one or more tires or wheels on your vehicle to ensure that the replacement or alternate tires and wheels allow the TPMS to continue to function properly.

### NOTICE

**If any of the below happens, we recommend that the system be checked by an authorized HYUNDAI dealer.**

- 1. The low tire pressure telltale/TPMS malfunction indicator does not illuminate for 3 seconds when the ignition switch is turned to the ON position or the engine is running.**
- 2. The TPMS malfunction indicator remains illuminated after blinking for approximately 1 minute.**
- 3. The Low tire pressure position telltale remains illuminated.**



**Low tire pressure telltale**



**Low tire pressure position telltale and tire pressure telltale**

When the tire pressure monitoring system warning indicators are illuminated and a warning message displayed on the cluster LCD display, one or more of your tires is significantly under-inflated. The low tire pressure position telltale light will indicate which tire is significantly under-inflated by illuminating the corresponding position light.

If either telltale illuminates, immediately reduce your speed, avoid hard cornering and anticipate increased stopping distances. You should stop and check your tires as soon as possible. Inflate the tires to the proper pressure as indicated on the vehicle's placard or tire inflation pressure label located on the driver's side center pillar outer panel. If you cannot reach a service station or if the tire cannot hold the newly added air, replace the low pressure tire with a spare tire.

If you drive the vehicle for about 10 minutes at speeds above 25 km/h after replacing the low pressure tire with the spare tire, the below will happen:

- The TPMS malfunction indicator may blink for approximately 1 minute and then remain continuously illuminated because the TPMS sensor is not mounted on the spare wheel.

**NOTICE**

**The spare tire is not equipped with a tire pressure sensor.**

 **CAUTION**

**In winter or cold weather, the low tire pressure telltale may illuminate if the tire pressure was adjusted to the recommended tire inflation pressure in warm weather. It does not mean your TPMS is malfunctioning because the decreased temperature leads to a lowering of tire pressure.**

**When you drive your vehicle from a warm area to a cold area or from a cold area to a warm area, or the outside temperature is higher or lower, you should check the tire inflation pressure and adjust the tires to the recommended tire inflation pressure.**

 **WARNING****Low pressure damage**

**Significantly low tire pressure makes the vehicle unstable and can contribute to loss of vehicle control and increased braking distances.**

**Continued driving on low pressure tires can cause the tires to overheat and fail.**



### TPMS (Tire Pressure Monitoring System) malfunction indicator

The TPMS malfunction indicator will illuminate after it blinks for approximately one minute when there is a problem with the Tire Pressure Monitoring System.

We recommend that the system be checked by an authorized HYUNDAI dealer.

#### NOTICE

**If there is a malfunction with the TPMS, the low tire pressure position telltale will not be displayed even though the vehicle has an under-inflated tire.**

#### CAUTION

- **The TPMS malfunction indicator may blink for approximately 1 minute and then remain continuously illuminated if the vehicle is moving around electric power supply cables or radios transmitter such as at police stations, government and public offices, broadcasting stations, military installations, airports, or transmitting towers, etc. This can interfere with normal operation of the Tire Pressure Monitoring System (TPMS).**
- **The TPMS malfunction indicator may blink for approximately 1 minute and then remain continuously illuminated if snow chains are used or some separate electronic devices such as notebook computer, mobile charger, remote starter or navigation etc., are used in the vehicle.**

**This can interfere with normal operation of the Tire Pressure Monitoring System (TPMS).**

### Changing a tire with TPMS

If you have a flat tire, the low Tire Pressure and Position telltales will come on. We recommend that the system be checked by an authorized HYUNDAI dealer.

#### CAUTION

**NEVER use a puncture-repairing agent to repair and/or inflate a low pressure tire. The tire sealant can damage the tire pressure sensor. If used, you will have to replace the tire pressure sensor.**

Each wheel is equipped with a tire pressure sensor mounted inside the tire behind the valve stem. You must use TPMS specific wheels. It is recommended that you have your tires serviced by an authorized HYUNDAI dealer.

---

If you drive the vehicle for about 10 minutes at speeds above 25 km/h after replacing the low pressure tire with the spare tire, the below will happen:

- The TPMS malfunction indicator may blink for approximately 1 minute and then remain continuously illuminated because the TPMS sensor is not mounted on the spare wheel.

You may not be able identify a tire with low pressure by simply looking at it. Always use a good quality tire pressure gauge to measure the tire's inflation pressure. Please note that a tire that is hot (from being driven) will have a higher pressure measurement than a tire that is cold (from sitting stationary for at least 3 hour and driven less than 1.6 km (1 mile) during that 3 hour period).

Allow the tire to cool before measuring the inflation pressure. Always be sure the tire is cold before inflating to the recommended pressure.

A cold tire means the vehicle has been sitting for 3 hours and driven for less than 1.6 km (1 mile) in that 3 hour period.

### WARNING

- **The TPMS cannot alert you to severe and sudden tire damage caused by external factors such as nails or road debris.**
- **If you feel any vehicle instability, immediately take your foot off the accelerator, apply the brakes gradually and with light force, and slowly move to a safe position off the road.**

**⚠ WARNING**

Tampering with, modifying, or disabling the Tire Pressure Monitoring System (TPMS) components may interfere with the system's ability to warn the driver of low tire pressure conditions and/or TPMS malfunctions. Tampering with, modifying, or disabling the Tire Pressure Monitoring System (TPMS) components may void the warranty for that portion of the vehicle.

**⚠ WARNING**

For EUROPE

- Do not modify the vehicle; it may interfere with the TPMS function.
- The wheels on the market do not have a TPMS sensor.

For your safety, we recommend that you use parts for replacement from an authorized HYUNDAI dealer.

- If you use the wheels on the market, use a TPMS sensor approved by a HYUNDAI dealer. If your vehicle is not equipped with a TPMS sensor or TPMS does not work properly, you may fail the periodic vehicle inspection conducted in your country.

(Continued)

(Continued)

\*All vehicles sold in the EUROPE market during below period must be equipped with TPMS.

- New model vehicle :  
Nov. 1, 2012 ~

- Current model vehicle :  
Nov. 1, 2014~ (Based on  
vehicle registrations)

## IF YOU HAVE A FLAT TIRE (WITH SPARE TIRE, IF EQUIPPED)

### WARNING

Changing a tire can be dangerous. Follow the instructions in this section when changing a tire to reduce the risk of serious injury or death.

### CAUTION

Be careful as you use the jack handle to stay clear of the flat end. The flat end has sharp edges that could cause cuts.

### Jack and tools

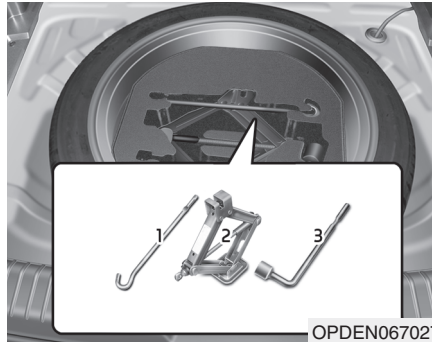

- (1) Jack handle
- (2) Jack
- (3) Wheel nut wrench

The jack, jack handle, and wheel nut wrench are stored in the luggage compartment under the luggage box cover.

The jack is provided for emergency tire changing only.

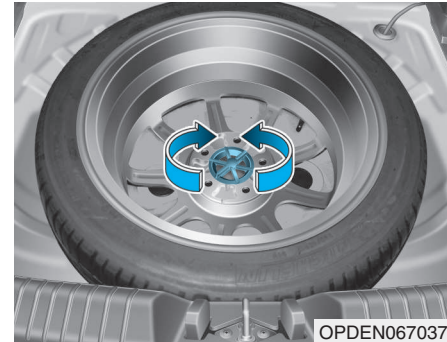

Turn the winged hold down bolt counterclockwise to remove the spare tire.

Store the spare tire in the same compartment by turning the winged hold down bolt clockwise.

To prevent the spare tire and tools from "rattling", store them in their proper location.





If it is hard to loosen the tire hold-down wing bolt by hand, you can loosen it easily using the jack handle.

1. Put the jack handle (1) inside of the tire hold-down wing bolt.
2. Turn the tire hold-down wing bolt counterclockwise with the jack handle.

### Changing tires

#### **⚠ WARNING**

A vehicle can slip or roll off of a jack causing serious injury or death to you or those nearby. Take the following safety precautions:

- Do not get under a vehicle that is supported by a jack.
- NEVER attempt to change a tire in the lane of traffic. ALWAYS move the vehicle completely off the road on level, firm ground away from traffic before trying to change a tire. If you cannot find a level, firm place off the road, call a towing service for assistance.
- Be sure to use the jack provided with the vehicle.

(Continued)

(Continued)

- ALWAYS place the jack on the designated jacking positions on the vehicle and NEVER on the bumpers or any other part of the vehicle for jacking support.
- Do not start or run the engine while the vehicle is on the jack.
- Do not allow anyone to remain in the vehicle while it is on the jack.
- Keep children away from the road and the vehicle.

Follow these steps to change your vehicle's tire:

1. Park on a level, firm surface.
2. Move the shift lever into neutral, apply the parking brake, and place the ignition switch in the LOCK/OFF position.
3. Press the hazard warning flasher button.
4. Remove the wheel lug nut wrench, jack, jack handle, and spare tire from the vehicle.

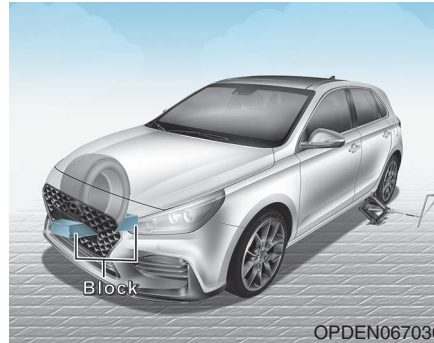

5. Block both the front and rear of the tire diagonally opposite of the tire you are changing.

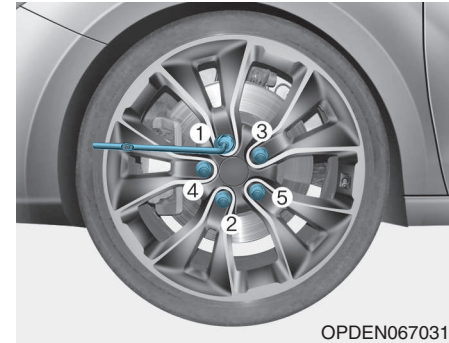

6. Loosen the wheel lug nuts counterclockwise one turn each in the order shown above, but do not remove any lug nuts until the tire has been raised off of the ground.

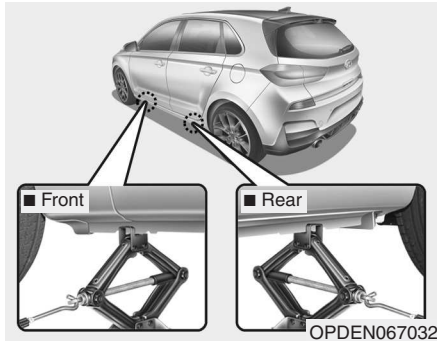

7. Place the jack at the designated jacking position under the frame closest to the tire you are changing. The jacking positions are plates welded to the frame with two notches. Never jack at any other position or part of the vehicle. It may damage the side seal molding.

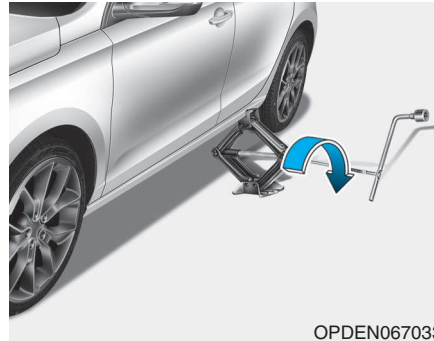

8. Insert the jack handle into the jack and turn it clockwise, raising the vehicle until the tire clears the ground. Make sure the vehicle is stable on the jack.

9. Loosen the lug nuts with the wheel lug nut wrench and remove them with your fingers. Remove the wheel from the studs and lay it flat on the ground out of the way. Remove any dirt or debris from the studs, mounting surfaces, and wheel.

10. Install the spare tire onto the studs of the hub.

11. Tighten the lug nuts with your fingers onto the studs with the smaller end of the lug nuts closest to the wheel.

12. Lower the vehicle to the ground by turning the jack handle counterclockwise.

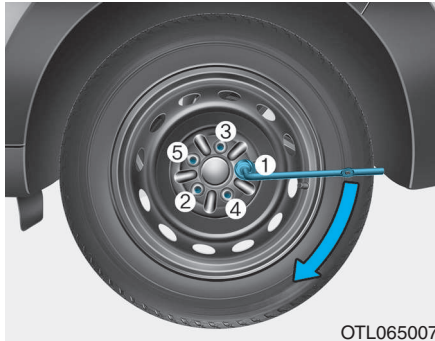

OTL065007

13. Use the wheel lug nut wrench to tighten the lug nuts in the order shown. Double-check each lug nut until they are tight. After changing tires, we recommend that an authorized HYUNDAI dealer tighten the lug nuts to their proper torque as soon as possible. **The wheel lug nut should be tightened to 11~13 kgf-m (79~94 lbf-ft).**

If you have a tire gauge, check the tire pressure (see "Tires and Wheels" in chapter 8 for tire pressure instructions.). If the pressure is lower or higher than recommended, drive slowly to the nearest service station and adjust it to the recommended pressure. Always reinstall the valve cap after checking or adjusting tire pressure. If the cap is not replaced, air may leak from the tire. If you lose a valve cap, buy another and install it as soon as possible. After changing tires, secure the flat tire and return the jack and tools to their proper storage locations.

#### NOTICE

- **Check the tire pressure as soon as possible after installing a spare tire. Adjust it to the recommended pressure.**
- **Check and tighten the wheel lug nuts after driving over 50 km if tires are replaced. Re-check the tire wheel lug nuts after driving over 1,000 km.**

#### ⚠ CAUTION

**Your vehicle has metric threads on the studs and lug nuts. Make certain during tire changing that the same nuts that were removed are reinstalled. If you have to replace your lug nuts make sure they have metric threads to avoid damaging the studs and ensure the wheel is properly secured to the hub. We recommend that you consult an authorized HYUNDAI dealer for assistance.**

If any of the equipment such as the jack, lug nuts, studs, or other equipment is damaged or in poor condition, do not attempt to change the tire and call for assistance.

### ***Use of compact spare tires (if equipped)***

Compact spare tires are designed for emergency use only. Drive carefully on the compact spare tire and always follow the safety precautions.

#### **WARNING**

**To prevent compact spare tire failure and loss of control possibly resulting in an accident:**

- **Use the compact spare tire only in an emergency.**
- **NEVER operate your vehicle over 80 km/h (50 mph).**
- **Do not exceed the vehicle's maximum load rating or the load carrying capacity shown on the sidewall of the compact spare tire.**
- **Do not use the compact spare tire continuously. Repair or replace the original tire as soon as possible to avoid failure of the compact spare tire.**

When driving with the compact spare tire mounted to your vehicle:

- Check the tire pressure after installing the compact spare tire. The compact spare tire should be inflated to 420 kPa (60 psi).
- Do not take this vehicle through an automatic car wash while the compact spare tire is installed.
- Do not use the compact spare tire on any other vehicle because this tire has been designed especially for your vehicle.
- The compact spare tire's tread life is shorter than a regular tire. Inspect your compact spare tire regularly and replace worn compact spare tires with the same size and design, mounted on the same wheel.
- Do not use more than one compact spare tire at a time.
- Do not tow a trailer while the compact spare tire is installed.

#### **NOTICE**

**When the original tire and wheel are repaired and reinstalled on the vehicle, the lug nut torque must be set correctly. The correct lug nut tightening torque is 11~13 kgf·m (79~94 lbf·ft).**

## ⚠ CAUTION

To prevent damaging the compact spare tire and your vehicle:

- Drive slowly enough for the road conditions to avoid all hazards, such as a potholes or debris.
- Avoid driving over obstacles. The compact spare tire diameter is smaller than the diameter of a conventional tire and reduces the ground clearance approximately 25 mm (1 inch).
- Do not use tire chains on the compact spare tire. Because of the smaller size, a tire chain will not fit properly.
- Do not use the compact spare tire on any other wheels, nor should standard tires, snow tires, wheel covers or trim rings be used with the compact spare wheel.

## Jack label

### ■ Example

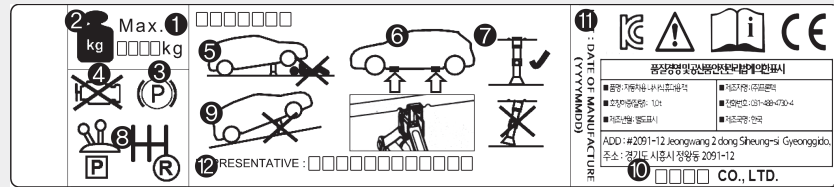

OHYK065011

The actual Jack label in the vehicle may differ from the illustration.

For more detailed specifications, refer to the label attached to the jack.

1. Model Name
2. Maximum allowable load
3. When using the jack, set your parking brake.
4. When using the jack, stop the engine.
5. Do not get under a vehicle that is supported by a jack.
6. The designated locations under the frame
7. When supporting the vehicle, the base plate of jack must be vertical under the lifting point.
8. Shift into Reverse gear on vehicles with manual transmission or move the shift lever to the P position on vehicles with automatic transmission/ dual clutch transmission.
9. The jack should be used on firm level ground.
10. Jack manufacture
11. Production date
12. Representative company and address

### EC Declaration of conformity for Jack



**EC Declaration of Conformity**  
according to EC Machinery Directive 2006/42/EC

We, **FRONTEC CO., LTD.**

**2091-12 Jeongwang 2(i)-dong Siheung-si Gyeonggi-d ,Korea**

declare under our sole responsibility that the product

**Product : JACK-ASSY**

**Type Designation(s) : 1200KG, 1000KG, 800KG, 700KG, 500KG**

**Serial No. : N/A (prototype)**

**Year of Manufacture : 2013**

to which this declaration relates is in conformity with the following standard(s) or other normative document(s);

EN ISO12100 (2010)	Safety of machinery - General principles for design – Risk assessment and risk reduction
EN 1494/A1 (2008)	Mobile or movable jacks and associated lifting equipment

following the provisions of Directive(s);

2006/42/EC	Directive on the approximation of the laws of Member States relating to machinery (OJ L157 Jun, 9, 2006)
------------	---

Siheung-si Gyeonggi-d ,Korea / 15.07.2013 SOO HONG, MIN President 

(Place and date of issue)(Name and signature or equivalent making of authorized person)

\* T.C.F Compiling Location:

- Address: PRIBORSKA 280, 739 42 FRYDEK MISTEK, CHLEBOVICE, CZECH REPUBLIC
- Team: Purchase team
- Company name: HANWHA L&C CZECH s.r.o

JACKDOC14F

## IF YOU HAVE A FLAT TIRE (WITH TIRE MOBILITY KIT, IF EQUIPPED) – TYPE A

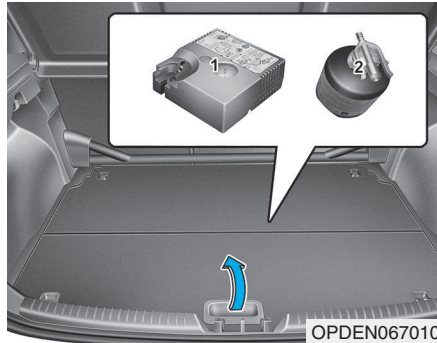

For safe operation, carefully read and follow the instructions in this manual before use.

- (1) Compressor
- (2) Sealant bottle

The Tire Mobility Kit is a temporary fix to the tire and we recommend that the system be inspected by an authorized HYUNDAI dealer.

### ⚠ CAUTION

**When two or more tires are flat, do not use the tire mobility kit because the supported one sealant of Tire Mobility Kit is only used for one flat tire.**

### ⚠ WARNING

**Do not use the Tire Mobility Kit to repair punctures in the tire walls. This can result in an accident due to tire failure.**

### ⚠ WARNING

**Have your tire repaired as soon as possible. The tire may lose air pressure at any time after inflating with the Tire Mobility Kit.**

### Introduction

With the Tire Mobility Kit you stay mobile even after experiencing a tire puncture.

The system of compressor and sealing compound effectively and comfortably seals most punctures in a passenger car tire caused by nails or similar objects and reinflates the tire.

After you ensured that the tire is properly sealed you can drive cautiously on the tire (distance up to 200 km (120 miles)) at a max. speed of 80 km/h (50 mph) in order to reach a service station or tire dealer to have the tire replaced.

It is possible that some tires, especially with larger punctures or damage to the sidewall, cannot be sealed completely.

Air pressure loss in the tire may adversely affect tire performance.

For this reason, you should avoid abrupt steering or other driving maneuvers, especially if the vehicle is heavily loaded or if a trailer is in use.



The Tire Mobility Kit is not designed or intended as a permanent tire repair method and is to be used for one tire only. This instruction shows you step by step how to temporarily seal the puncture simply and reliably. Read the section "Notes on the safe use of the Tire Mobility Kit".

### WARNING

**Do not use the TMK if a tire is severely damaged by driving run flat or with insufficient air pressure.**

**Only punctured areas located within the tread region of the tire can be sealed using the TMK.**

### Notes on the safe use of the Tire Mobility Kit

- Park your car at the side of the road so that you can work with the Tire Mobility Kit away from moving traffic.
- To be sure your vehicle will not move, even when you're on fairly level ground, always set your parking brake.
- Only use the Tire Mobility Kit for sealing/inflation passenger car tires. Only punctured areas located within the tread region of the tire can be sealed using the tire mobility kit.
- Do not use on motorcycles, bicycles or any other type of tires.
- When the tire and wheel are damaged, do not use Tire Mobility Kit for your safety.
- Use of the Tire Mobility Kit may not be effective for tire damage larger than approximately 6 mm (0.24 in). If the tire cannot be made roadworthy with the Tire Mobility Kit, we recommend that you contact an authorized HYUNDAI dealer.
- Do not use the Tire Mobility Kit if a tire is severely damaged by driving run flat or with insufficient air pressure.
- Do not remove any foreign objects such as nails or screws that have penetrated the tire.
- Provided the car is outdoors, leave the engine running. Otherwise operating the compressor may eventually drain the car battery.
- Never leave the Tire Mobility Kit unattended while it is being used.
- Do not leave the compressor running for more than 10 min. at a time or it may overheat.
- Do not use the Tire Mobility Kit if the ambient temperature is below -30°C (-22°F).
- In case of skin contact with the sealant, wash the area thoroughly with plenty of water. If the irritation persists, seek medical attention.
- In case of eye contact with the sealant, flush your eyes for at least 15 minutes. If the irritation persists, seek medical attention.
- In case of swallowing the sealant, rinse the mouth and drink plenty of water. However, never give anything to an unconscious person and seek medical attention immediately.
- Long time exposure to the sealant may cause damage to bodily tissue such as kidney, etc.

## Components of the Tire Mobility Kit

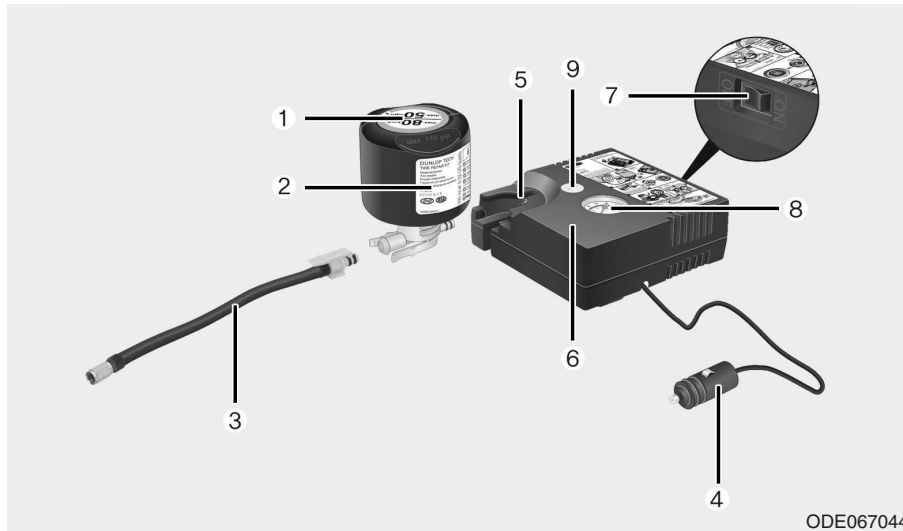

1. Speed-restriction label
2. Sealant bottle and label with speed restriction
3. Filling hose from sealant bottle to wheel
4. Connectors and cable for the power outlet direct connection
5. Holder for the sealant bottle
6. Compressor
7. ON/OFF switch
8. Pressure gauge for displaying the tire inflation pressure
9. Button for reducing the tire inflation pressure

Connectors, cable and connection hose are stored in the compressor housing.

Strictly follow the specified sequence, otherwise the sealant may escape under high pressure.

### **⚠ WARNING**

#### **Expired sealant**

**Do not use the Tire sealant after the sealant has expired (i.e. pasted the expiration date on the sealant container). This can increase the risk of tire failure.**

### **⚠ WARNING**

#### **Sealant**

- **Keep out of reach of children.**
- **Avoid contact with eyes.**
- **Do not swallow.**

## Using the Tire Mobility Kit

**CAUTION**

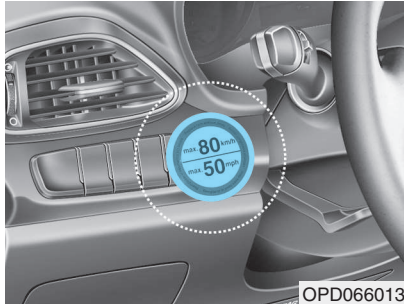

**Detach the speed restriction label (1) from the sealant bottle (2), and place it in a highly visible place inside the vehicle such as on the steering wheel to remind the driver not to drive too fast.**

1. Shake the sealant bottle (1).

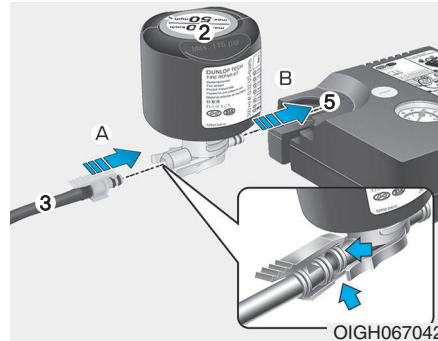

2. Connect the filling hose (3) to the sealant bottle (2) in the direction of (A) and connect the sealant bottle to the compressor (5) in the direction of (B).

3. Ensure that the compressor is switched OFF.

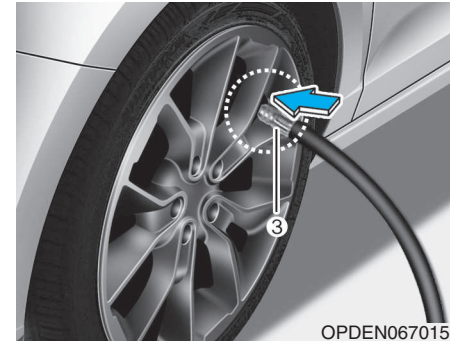

4. Unscrew the valve cap from the valve of the defective wheel and screw the filling hose (3) of the sealant bottle onto the valve.

### ⚠ CAUTION

Securely install the sealant filling hose to the valve. If not, sealant may flow backward, possibly clogging the filling hose.

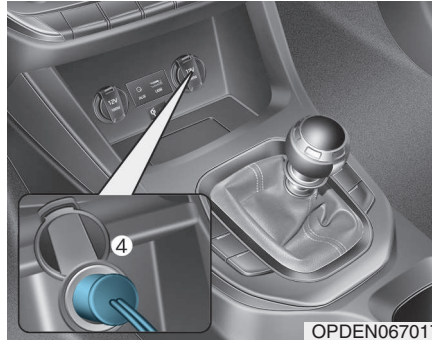

5. Plug the compressor power cord (4) into the vehicle power outlet.

### NOTICE

**Only use the front passenger side power outlet when connecting the power cord.**

6. With the ignition switch in the ON position, switch on the compressor and let it run for approximately 5~7 minutes to fill the sealant up to proper pressure. (refer to the Tire and Wheels, chapter 8). The inflation pressure of the tire after filling is unimportant and will be checked/corrected later.

Be careful not to overinflate the tire and stay away from the tire when filling it.

### ⚠ CAUTION

#### Tire pressure

**Do not attempt to drive your vehicle if the tire pressure is below 200 kPa (29 psi). This could result in an accident due to sudden tire failure.**

7. Switch off the compressor.
8. Detach the hoses from the sealant bottle connector and from the tire valve.

Return the Tire Mobility Kit to its storage location in the vehicle.

### ⚠ WARNING

#### Carbon monoxide

**Do not leave your vehicle running in a poorly ventilated area for extended periods of time. Carbon monoxide poisoning and suffocation can occur.**

### Distributing the sealant

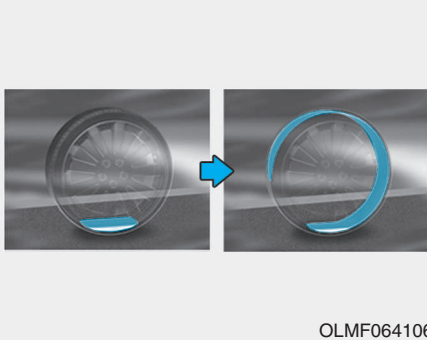

9. Immediately drive approximately 7~10 km (4~6 miles or, about 10min) to evenly distribute the sealant in the tire.

Do not exceed a speed of 80 km/h (50 mph). If possible, do not fall below a speed of 20 km/h (12 mph).

While driving, if you experience any unusual vibration, ride disturbance or noise, reduce your speed and drive with caution until you can safely pull off of the side of the road.

Call for road side service or towing.

### Checking the tire inflation pressure

1. After driving approximately 7~10 km (4~6 miles or about 10 min), stop at a safety location.

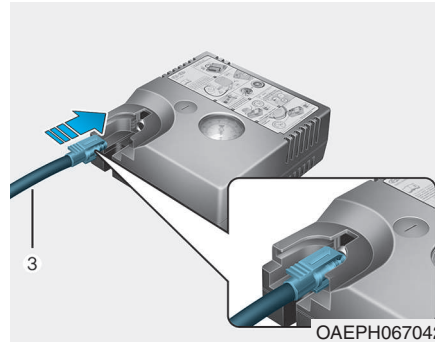

2. Connect the filling hose (3) directly into the compressor.

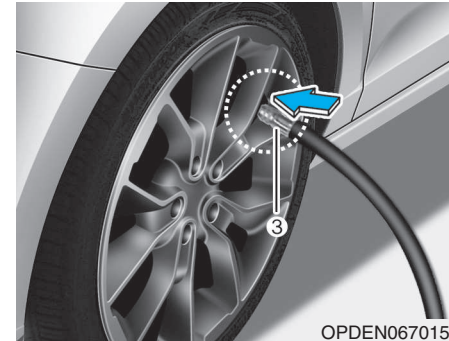

3. Connect the other end of the filling hose (3) directly into the tire valve.
4. Plug the compressor power cord (4) into the vehicle power outlet.
5. Adjust the tire inflation pressure to the recommended tire inflation.  
With the ignition switched on, proceed as follows.

- **To increase the inflation pressure** : Switch on the compressor.  
To check the current inflation pressure setting, briefly switch off the compressor.
- **To reduce the inflation pressure**: Press the button (9) on the compressor.

**NOTICE**

Do not let the compressor run for more than 10 minutes, otherwise the device will overheat and may be damaged.

**i Information**

The pressure gauge may show higher than actual reading when the compressor is running. To get an accurate tire reading, the compressor needs to be turned off.

**⚠ CAUTION**

If the inflation pressure is not maintained, drive the vehicle a second time, refer to Distributing the sealant. Then repeat steps 1 to 4.

Use of the TMK may be ineffectual for tire damage larger than approximately 4 mm (0.16 in).

We recommend that you contact an authorized HYUNDAI dealer if the tire cannot be made road-worthy with the Tire Mobility Kit.

**⚠ WARNING**

The tire inflation pressure must be at least 220 kPa (32 psi). If it is not, do not continue driving. Call for road side service or towing.

**⚠ CAUTION**

**Tire pressure sensor (if equipped with TPMS)**

The sealant on the tire pressure sensor and wheel should be removed when you replace the tire with a new one and inspect the tire pressure sensors at an authorized dealer.

**i Information**

When reinstalling the repaired or replaced tire and wheel on the vehicle, tighten the wheel lug nut to 11~13 kgf·m (79~94 lbf·ft).

## IF YOU HAVE A FLAT TIRE (WITH TIRE MOBILITY KIT, IF EQUIPPED) – TYPE B

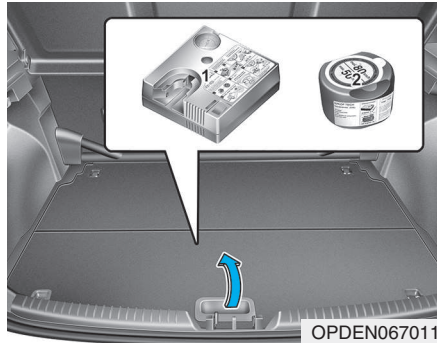

For safe operation, carefully read and follow the instructions in this manual before use.

- (1) Compressor
- (2) Sealant bottle

The Tire Mobility Kit is a temporary fix to the tire and we recommend that the system be inspected by an authorized HYUNDAI dealer.

### ⚠ CAUTION

**When two or more tires are flat, do not use the tire mobility kit because the supported one sealant of Tire Mobility Kit is only used for one flat tire.**

### ⚠ WARNING

**Do not use the Tire Mobility Kit to repair punctures in the tire walls. This can result in an accident due to tire failure.**

### ⚠ WARNING

**Have your tire repaired as soon as possible. The tire may lose air pressure at any time after inflating with the Tire Mobility Kit.**

### Introduction

With the Tire Mobility Kit you stay mobile even after experiencing a tire puncture.

The system of compressor and sealing compound effectively and comfortably seals most punctures in a passenger car tire caused by nails or similar objects and reinflates the tire.

After you ensured that the tire is properly sealed you can drive cautiously on the tire (distance up to 200 km (120 miles)) at a max. speed of 80 km/h (50 mph) in order to reach a service station or tire dealer to have the tire replaced.

It is possible that some tires, especially with larger punctures or damage to the sidewall, cannot be sealed completely.

Air pressure loss in the tire may adversely affect tire performance.

For this reason, you should avoid abrupt steering or other driving maneuvers, especially if the vehicle is heavily loaded or if a trailer is in use.

The Tire Mobility Kit is not designed or intended as a permanent tire repair method and is to be used for one tire only. This instruction shows you step by step how to temporarily seal the puncture simply and reliably. Read the section "Notes on the safe use of the Tire Mobility Kit".

### WARNING

**Do not use the TMK if a tire is severely damaged by driving run flat or with insufficient air pressure.**

**Only punctured areas located within the tread region of the tire can be sealed using the TMK.**

### Notes on the safe use of the Tire Mobility Kit

- Park your car at the side of the road so that you can work with the Tire Mobility Kit away from moving traffic.
- To be sure your vehicle will not move, even when you're on fairly level ground, always set your parking brake.
- Only use the Tire Mobility Kit for sealing/inflation passenger car tires. Only punctured areas located within the tread region of the tire can be sealed using the tire mobility kit.
- Do not use on motorcycles, bicycles or any other type of tires.
- When the tire and wheel are damaged, do not use Tire Mobility Kit for your safety.
- Use of the Tire Mobility Kit may not be effective for tire damage larger than approximately 6 mm (0.24 in). If the tire cannot be made roadworthy with the Tire Mobility Kit, we recommend that you contact an authorized HYUNDAI dealer.
- Do not use the Tire Mobility Kit if a tire is severely damaged by driving run flat or with insufficient air pressure.
- Do not remove any foreign objects such as nails or screws that have penetrated the tire.
- Provided the car is outdoors, leave the engine running. Otherwise operating the compressor may eventually drain the car battery.
- Never leave the Tire Mobility Kit unattended while it is being used.
- Do not leave the compressor running for more than 10 min. at a time or it may overheat.
- Do not use the Tire Mobility Kit if the ambient temperature is below  $-30^{\circ}\text{C}$  ( $-22^{\circ}\text{F}$ ).
- In case of skin contact with the sealant, wash the area thoroughly with plenty of water. If the irritation persists, seek medical attention.
- In case of eye contact with the sealant, flush your eyes for at least 15 minutes. If the irritation persists, seek medical attention.
- In case of swallowing the sealant, rinse the mouth and drink plenty of water. However, never give anything to an unconscious person and seek medical attention immediately.
- Long time exposure to the sealant may cause damage to bodily tissue such as kidney, etc.



### Components of the Tire Mobility Kit

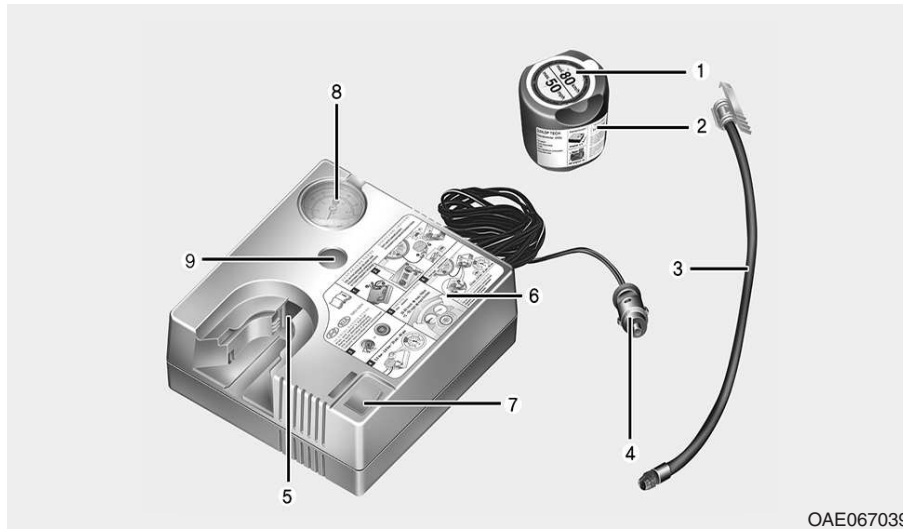

1. Speed-restriction label
2. Sealant bottle and label with speed restriction
3. Filling hose from sealant bottle to wheel
4. Connectors and cable for the power outlet direct connection
5. Holder for the sealant bottle
6. Compressor
7. ON/OFF switch
8. Pressure gauge for displaying the tire inflation pressure
9. Button for reducing the tire inflation pressure

Connectors, cable and connection hose are stored in the compressor housing.

Strictly follow the specified sequence, otherwise the sealant may escape under high pressure.

#### **⚠ WARNING**

##### **Expired sealant**

**Do not use the Tire sealant after the sealant has expired (i.e. pasted the expiration date on the sealant container). This can increase the risk of tire failure.**

#### **⚠ WARNING**

##### **Sealant**

- **Keep out of reach of children.**
- **Avoid contact with eyes.**
- **Do not swallow.**

## Using the Tire Mobility Kit

### ⚠ CAUTION

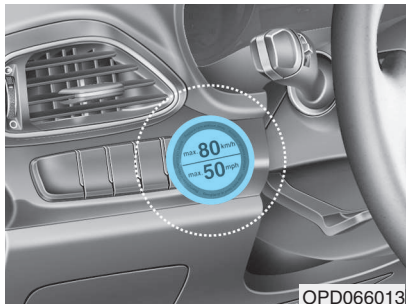

OPD066013

**Detach the speed restriction label (1) from the sealant bottle (2), and place it in a highly visible place inside the vehicle such as on the steering wheel to remind the driver not to drive too fast.**

1. Shake the sealant bottle (1).

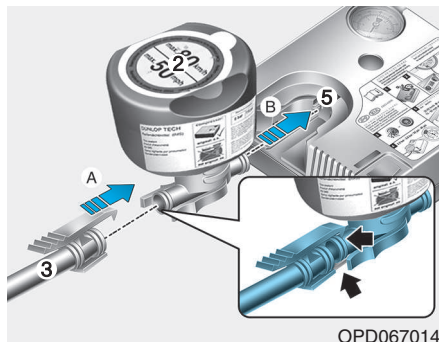

OPD067014

2. Connect the filling hose (3) to the sealant bottle (2) in the direction of (A) and connect the sealant bottle to the compressor (5) in the direction of (B).
3. Ensure that the compressor is switched OFF.

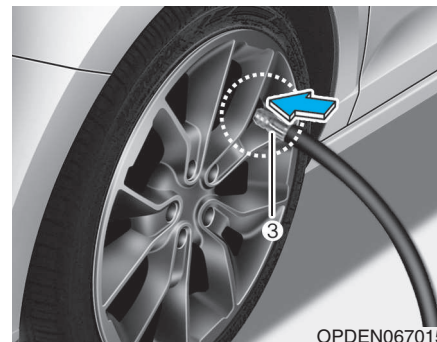

OPDEN067015

4. Unscrew the valve cap from the valve of the defective wheel and screw the filling hose (3) of the sealant bottle onto the valve.

**! CAUTION**

Securely install the sealant filling hose to the valve. If not, sealant may flow backward, possibly clogging the filling hose.

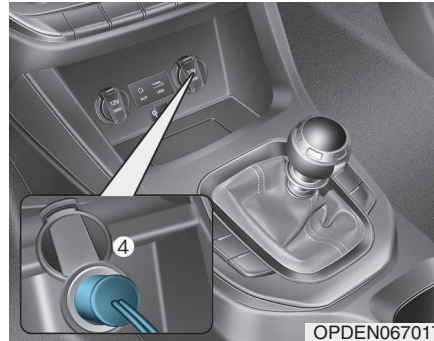

5. Plug the compressor power cord (4) into the vehicle power outlet.

**NOTICE**

**Only use the front passenger side power outlet when connecting the power cord.**

6. With the ignition switch in the ON position, switch on the compressor and let it run for approximately 5~7 minutes to fill the sealant up to proper pressure. (refer to the Tire and Wheels, chapter 8). The inflation pressure of the tire after filling is unimportant and will be checked/corrected later.

Be careful not to overinflate the tire and stay away from the tire when filling it.

**! CAUTION**

**Tire pressure**

**Do not attempt to drive your vehicle if the tire pressure is below 200 kPa (29 psi). This could result in an accident due to sudden tire failure.**

7. Switch off the compressor.
8. Detach the hoses from the sealant bottle connector and from the tire valve.

Return the Tire Mobility Kit to its storage location in the vehicle.

**! WARNING**

**Carbon monoxide**

**Do not leave your vehicle running in a poorly ventilated area for extended periods of time. Carbon monoxide poisoning and suffocation can occur.**

## Distributing the sealant

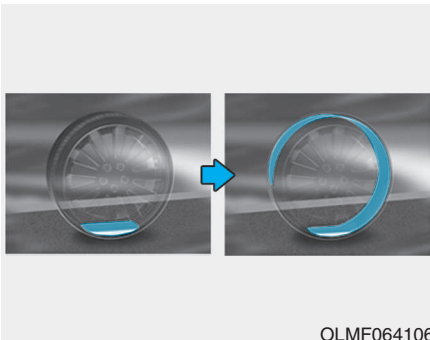

9. Immediately drive approximately 7~10 km (4~6 miles or, about 10min) to evenly distribute the sealant in the tire.

Do not exceed a speed of 80 km/h (50 mph). If possible, do not fall below a speed of 20 km/h (12 mph).

While driving, if you experience any unusual vibration, ride disturbance or noise, reduce your speed and drive with caution until you can safely pull off of the side of the road.

Call for road side service or towing.

## Checking the tire inflation pressure

1. After driving approximately 7~10 km (4~6 miles or about 10 min), stop at a safety location.

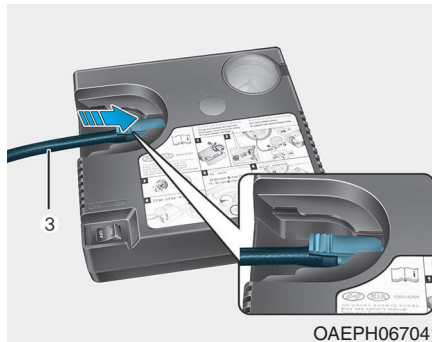

2. Connect the filling hose (3) directly into the compressor.

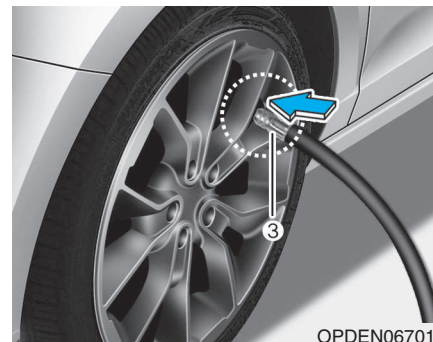

3. Connect the other end of the filling hose (3) directly into the tire valve.  
4. Plug the compressor power cord (4) into the vehicle power outlet.

5. Adjust the tire inflation pressure to the recommended tire inflation.  
With the ignition switched on, proceed as follows.

**- To increase the inflation pressure :** Switch on the compressor.  
To check the current inflation pressure setting, briefly switch off the compressor.

**- To reduce the inflation pressure:** Press the button (9) on the compressor.

### **NOTICE**

Do not let the compressor run for more than 10 minutes, otherwise the device will overheat and may be damaged.

### **i Information**

The pressure gauge may show higher than actual reading when the compressor is running. To get an accurate tire reading, the compressor needs to be turned off.

### **⚠ CAUTION**

If the inflation pressure is not maintained, drive the vehicle a second time, refer to Distributing the sealant. Then repeat steps 1 to 4.

Use of the TMK may be ineffectual for tire damage larger than approximately 4 mm (0.16 in).

We recommend that you contact an authorized HYUNDAI dealer if the tire cannot be made road-worthy with the Tire Mobility Kit.

### **⚠ WARNING**

The tire inflation pressure must be at least 220 kPa (32 psi). If it is not, do not continue driving. Call for road side service or towing.

### **⚠ CAUTION**

Tire pressure sensor (if equipped with TPMS)

The sealant on the tire pressure sensor and wheel should be removed when you replace the tire with a new one and inspect the tire pressure sensors at an authorized dealer.

### **i Information**

When reinstalling the repaired or replaced tire and wheel on the vehicle, tighten the wheel lug nut to 11~13 kgf·m (79~94 lbf·ft).

## TOWING

### Towing service

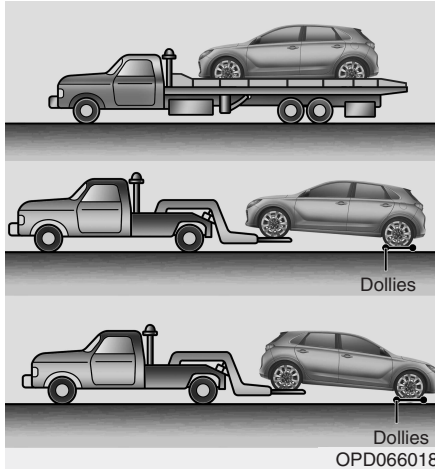

If emergency towing is necessary, we recommend having it done by an authorized HYUNDAI dealer or a commercial tow-truck service.

Proper lifting and towing procedures are necessary to prevent damage to the vehicle. The use of wheel dollies or flatbed is recommended.

It is acceptable to tow the vehicle with the rear wheels on the ground (without dollies) and the front wheels off the ground.

If any of the loaded wheels or suspension components are damaged or the vehicle is being towed with the front wheels on the ground, use a towing dolly under the front wheels.

When being towed by a commercial tow truck and wheel dollies are not used, the front of the vehicle should always be lifted, not the rear.

### ⚠ CAUTION

- Do not tow the vehicle with the front wheels on the ground as this may cause damage to the vehicle.

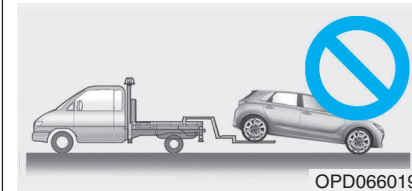

- Do not tow with sling-type equipment. Use wheel lift or flatbed equipment.

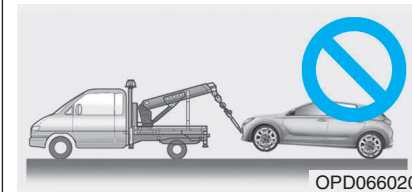

### **WARNING**

If your vehicle is equipped with a rollover sensor, place the ignition switch in the LOCK/OFF or ACC position when the vehicle is being towed. The side impact and curtain air bag may deploy if the sensor detects the situation as a rollover.

When towing your vehicle in an emergency without wheel dollies:

1. Place the ignition switch in the LOCK/OFF or ACC position.
2. Place the shift lever in neutral.
3. Release the parking brake.

### **CAUTION**

Failure to place the shift lever in neutral may cause internal damage to the transmission.

## Removable towing hook

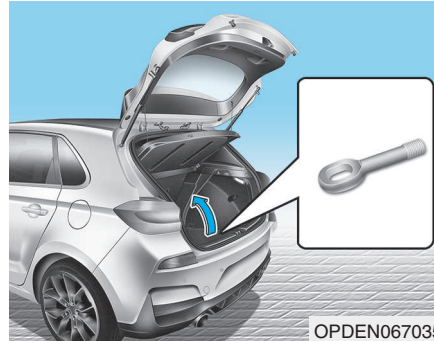

1. Open the tailgate, and remove the towing hook from the tool case.

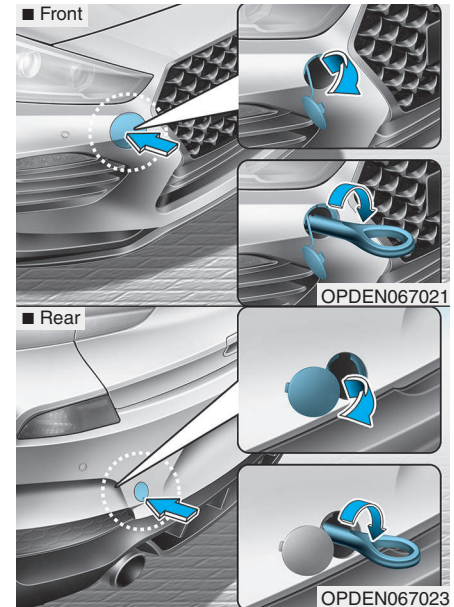

2. Remove the hole cover pressing the lower part of the cover on the bumper.
3. Install the towing hook by turning it clockwise into the hole until it is fully secured.
4. Remove the towing hook and install the cover after use.

## Emergency towing

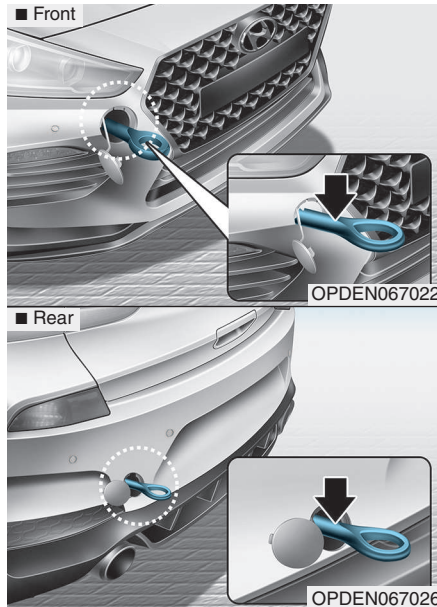

If towing is necessary, we recommend you have it done by an authorized HYUNDAI dealer or a commercial tow truck service.

If a towing service is not available in an emergency, your vehicle may be temporarily towed using a cable or chain secured to the emergency towing hook at the front (or rear) of the vehicle.

Use extreme caution when towing the vehicle with a cable or chain. A driver must be in the vehicle to steer it and operate the brakes.

Towing in this manner may be done only on hard-surfaced roads for a short distance and at low speeds. Also, the wheels, axles, power train, steering and brakes must all be in good condition.

Always follow these emergency towing precautions:

- Place the ignition switch in the ACC position so the steering wheel is not locked.
- Place the shift lever in neutral.
- Release the parking brake.
- Depress the brake pedal with more force than normal as you will have reduced braking performance.
- More steering effort will be required because the power steering system will be disabled.
- Use a vehicle heavier than your own to tow your vehicle.
- The drivers of both vehicles should communicate with each other frequently.
- Before emergency towing, check that the hook is not broken or damaged.
- Fasten the towing cable or chain securely to the hook.
- Do not jerk the hook. Apply steady and even force.



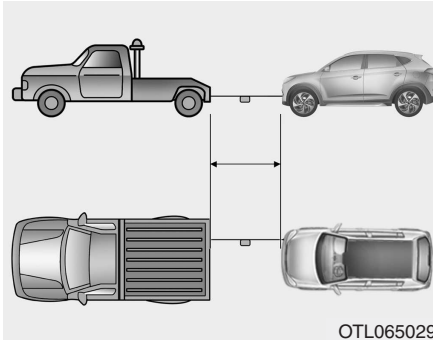

- Use a towing cable or chain less than 5 m (16 feet) long. Attach a white or red cloth (about 30 cm (12 inches) wide) in the middle of the cable or chain for easy visibility.
- Drive carefully so the towing cable or chain remains tight during towing.

### CAUTION

To avoid damage to your vehicle and vehicle components when towing:

- Always pull straight ahead when using the towing hooks. Do not pull from the side or at a vertical angle.
- Do not use the towing hooks to pull a vehicle out of mud, sand or other conditions from which the vehicle cannot be driven out under its own power.

## EMERGENCY COMMODITY (IF EQUIPPED)

Your vehicle is equipped with emergency commodities to help you respond to emergency situation.

### Fire extinguisher

If there is small fire and you know how to use the fire extinguisher, follow these steps carefully.

1. Pull out the safety pin at the top of the extinguisher that keeps the handle from being accidentally pressed.
2. Aim the nozzle towards the base of the fire.
3. Stand approximately 2.5 m (8 ft) away from the fire and squeeze the handle to discharge the extinguisher. If you release the handle, the discharge will stop.
4. Sweep the nozzle back and forth at the base of the fire. After the fire appears to be out, watch carefully since it may re-ignite.

### First aid kit

Supplies for use in giving first aid such as scissors, bandage and adhesive tape, etc. are provided.

### Triangle reflector

Place the triangle reflector on the road to warn oncoming vehicles during emergencies, such as when the vehicle is parked by the roadside due to problems.

### Tire pressure gauge (if equipped)

Tires normally lose some air in day-to-day use, and you may have to add a air periodically and usually it is not a sign of a leaking tire, but of normal wear. Always check tire pressure when the tires are cold because tire pressure increases with temperature.

To check the tire pressure, take the following steps:

1. Unscrew the inflation valve cap that is located on the rim of the tire.
2. Press and hold the gauge against the tire valve. Some air will leak as you begin and more will leak if you don't press the gauge in firmly.
3. A firm non-leaking push will activate the gauge.
4. Read the tire pressure on the gauge to see whether the tire pressure is low or high.
5. Adjust the tire pressure to the specified pressure. Refer to "Tires and Wheels" in chapter 8.
6. Reinstall the inflation valve cap.

# Maintenance

<b>Engine compartment</b> .....	7-3	<b>Brake/clutch fluid</b> .....	7-25
<b>Maintenance services</b> .....	7-4	Checking the brake/clutch fluid level .....	7-25
Owner's responsibility .....	7-4	<b>Washer fluid</b> .....	7-26
Owner maintenance precautions .....	7-4	Checking the washer fluid level .....	7-26
<b>Owner maintenance</b> .....	7-5	<b>Parking brake</b> .....	7-26
Owner maintenance schedule .....	7-5	Checking the parking brake .....	7-26
<b>Scheduled maintenance services</b> .....	7-7	<b>Air cleaner</b> .....	7-27
Normal Maintenance Schedule (for Europe) .....	7-8	Filter replacement .....	7-27
Maintenance Under Severe Usage and		<b>Climate control air filter</b> .....	7-29
Low Mileage Conditions (for Europe) .....	7-11	Filter inspection .....	7-29
Normal Maintenance Schedule (except Europe) .....	7-13	Filter replacement .....	7-29
Maintenance Under Severe Usage and		<b>Wiper blades</b> .....	7-30
Low Mileage Conditions (except Europe) .....	7-16	Blade inspection .....	7-30
<b>Explanation of scheduled maintenance items</b> .....	7-18	Blade replacement .....	7-31
<b>Engine oil</b> .....	7-20	<b>Battery</b> .....	7-33
Checking the engine oil level .....	7-20	For best battery service .....	7-34
Checking the engine oil and filter .....	7-21	Battery capacity label .....	7-34
<b>Engine coolant</b> .....	7-22	Battery recharging .....	7-35
Checking the engine coolant level .....	7-22	Reset items .....	7-36
Changing the engine coolant .....	7-24		

<b>Tires and wheels</b> .....	7-37
Tire care .....	7-38
Recommended cold tire inflation pressures .....	7-38
Check tire inflation pressure .....	7-39
Tire rotation .....	7-39
Wheel alignment and tire balance .....	7-40
Tire replacement .....	7-41
Wheel replacement .....	7-42
Tire traction .....	7-42
Tire maintenance .....	7-42
Tire sidewall labeling .....	7-42
Low aspect ratio tires .....	7-46
<b>Fuses</b> .....	7-47
Instrument panel fuse replacement .....	7-48
Engine compartment panel fuse replacement .....	7-49
Fuse/Relay panel description .....	7-51

<b>Light bulbs</b> .....	7-61
Headlamp, static bending lamp, position lamp, turn signal lamp and daytime running light bulb replacement .....	7-62
Headlamp aiming (for Europe) .....	7-62
Side repeater lamp replacement .....	7-66
Rear combination lamp bulb replacement .....	7-66
Rear fog lamp replacement .....	7-68
High mounted stop lamp replacement .....	7-69
License plate light bulb replacement .....	7-69
Interior light bulb replacement .....	7-69
<b>Appearance care</b> .....	7-71
Exterior care .....	7-71
Interior care .....	7-75
<b>Emission control system</b> .....	7-78
Crankcase emission control system .....	7-78
Evaporative emission control system .....	7-78
Exhaust emission control system .....	7-79

## ENGINE COMPARTMENT



1. Engine coolant reservoir/  
Engine coolant cap
2. Brake/clutch fluid reservoir
3. Air cleaner
4. Engine oil dipstick
5. Engine oil filler cap
6. Windshield washer fluid reservoir
7. Fuse box
8. Battery

**The actual engine compartment in the vehicle may differ from the illustration.**

OPDEN077088

### MAINTENANCE SERVICES

You should exercise the utmost care to prevent damage to your vehicle and injury to yourself whenever performing any maintenance or inspection procedures.

We recommend you have your vehicle maintained and repaired by an authorized HYUNDAI dealer. An authorized HYUNDAI dealer meets HYUNDAI's high service quality standards and receives technical support from HYUNDAI in order to provide you with a high level of service satisfaction.

#### Owner's responsibility

Maintenance service and record retention are the owner's responsibility.

You should retain documents that show proper maintenance has been performed on your vehicle in accordance with the scheduled maintenance service charts shown on the following pages. You need this information to establish your compliance with the servicing and maintenance requirements of your vehicle warranties.

Detailed warranty information is provided in your Service Passport.

Repairs and adjustments required as a result of improper maintenance or a lack of required maintenance are not covered.

#### Owner maintenance precautions

Inadequate, incomplete or insufficient servicing may result in operational problems with your vehicle that could lead to vehicle damage, an accident, or personal injury. This chapter provides instructions only for the maintenance items that are easy to perform.

Several procedures can be done only by an authorized HYUNDAI dealer with special tools.

Your vehicle should not be modified in any way. Such modifications may adversely affect the performance, safety or durability of your vehicle and may, in addition, violate conditions of the limited warranties covering the vehicle.

#### NOTICE

**Improper owner maintenance during the warranty period may affect warranty coverage. For details, read the separate Service Passport provided with the vehicle. If you're unsure about any servicing or maintenance procedure, we recommend that the system be serviced by an authorized HYUNDAI dealer.**

## OWNER MAINTENANCE

### WARNING

Performing maintenance work on a vehicle can be dangerous. If you lack sufficient knowledge and experience or the proper tools and equipment to do the work, we recommend that the system be serviced by an authorized HYUNDAI dealer. ALWAYS follow these precautions for performing maintenance work:

- Park your vehicle on level ground, move the shift lever into neutral, apply the parking brake, and place the ignition switch in the LOCK/ OFF position.
- Block the tires (front and back) to prevent the vehicle from moving.

Remove loose clothing or jewelry that can become entangled in moving parts.

(Continued)

(Continued)

- If you must run the engine during maintenance, do so out doors or in an area with plenty of ventilation.
- Keep flames, sparks, or smoking materials away from the battery and fuel-related parts.

The following lists are vehicle checks and inspections that should be performed by the owner or an authorized HYUNDAI dealer at the frequencies indicated to help ensure safe, dependable operation of your vehicle.

Any adverse conditions should be brought to the attention of your dealer as soon as possible.

These Owner Maintenance vehicle checks are generally not covered by warranties and you may be charged for labor, parts and lubricants used.

### Owner maintenance schedule

#### *When you stop for fuel:*

- Check the engine oil level.
- Check the coolant level in the engine coolant reservoir.
- Check the windshield washer fluid level.
- Check for low or under-inflated tires.

### WARNING

**Be careful when checking your engine coolant level when the engine is hot. This may result in coolant being blown out of the opening and cause serious burns and other injuries.**

### ***While operating your vehicle:***

- Note any changes in the sound of the exhaust or any smell of exhaust fumes in the vehicle.
- Check for vibrations in the steering wheel. Notice if there is any increased steering effort or looseness in the steering wheel, or change in its straight-ahead position.
- Notice if your vehicle constantly turns slightly or “pulls” to one side when traveling on smooth, level road.
- When stopping, listen and check for unusual sounds, pulling to one side, increased brake pedal travel or “hard-to-push” brake pedal.
- Check the parking brake.
- Check for fluid leaks under your vehicle (water dripping from the air conditioning system during or after use is normal).

### ***At least monthly:***

- Check coolant level in the engine coolant reservoir.
- Check the operation of all exterior lights, including the stoplights, turn signals and hazard warning flashers.
- Check the inflation pressures of all tires including the spare for tires that are worn, show uneven wear, or are damaged.
- Check for loose wheel lug nuts.

### ***At least twice a year: (i.e., every Spring and Autumn)***

- Check radiator, heater and air conditioning hoses for leaks or damage.
- Check windshield washer spray and wiper operation. Clean wiper blades with a clean cloth dampened with washer fluid.
- Check headlamp alignment.
- Check muffler, exhaust pipes, shields and clamps.
- Check the seat belts for wear and function.

### ***At least once a year:***

- Clean body and door drain holes.
- Lubricate door hinges and hood hinges.
- Lubricate door and hood locks and latches.
- Lubricate door rubber weather strips.
- Check the air conditioning system.
- Clean the battery and terminals.
- Check the brake fluid level.



---

## SCHEDULED MAINTENANCE SERVICES

Follow Normal Maintenance Schedule if the vehicle is usually operated where none of the following conditions apply. If any of the following conditions apply, you must follow the Maintenance Under Severe Usage Conditions.

- Repeated driving short distance of less than 8 km (5 miles) in normal temperature or less than 16 km (10 miles) in freezing temperature
- Extensive engine idling or low speed driving for long distances
- Driving on rough, dusty, muddy, unpaved, graveled or salt-spread roads
- Driving in areas using salt or other corrosive materials or in very cold weather
- Driving in heavy traffic area
- Driving on uphill, downhill, or mountain road repeatedly
- Towing a trailer or using a camper, or roof rack
- Driving as a patrol car, taxi, other commercial use of vehicle towing
- Driving over 170 km/h (106 mile/h)
- Frequently driving in stop-and-go condition

*If your vehicle is operated under the above conditions, you should inspect, replace or refill more frequently than the following Normal Maintenance Schedule. After the periods or distance shown in the chart, continue to follow the prescribed maintenance intervals.*

### Normal Maintenance Schedule (for Europe)

MAINTENANCE ITEM	MAINTENANCE INTERVALS	Months	24	48	72	96	120	144	168	192
		Miles x 1,000	20	40	60	80	100	120	140	160
		Km x 1,000	30	60	90	120	150	180	210	240
Drive belts * <sup>1</sup>	At first, inspect at 90,000 km (60,000 miles) or 72 months, after that, every 30,000 km (20,000 miles) or 24 months									
Engine oil and engine oil filter ** * <sup>2</sup>	Replace every 10,000 km (6,000 miles) or 12 months									
Fuel additives * <sup>3</sup>	Add every 10,000 km (6,000 miles) or 12 months									
Intercooler, in/out hose, air intake hose	Inspect every 10,000 km (6,000 miles)									
Air cleaner filter		I	R	I	R	I	R	I	R	
Spark plugs	Replace every 75,000 km (50,000 miles) * <sup>4</sup> or 60 months									
Vapor hose and fuel filler cap			I		I		I		I	
Fuel tank air filter			I		I		I		I	

I : Inspect and if necessary, adjust, correct, clean or replace.

R : Replace or change.

\*\* : The engine oil level should be checked regularly and maintained properly. Operating with an insufficient amount of oil can damage the engine, and such damage is not covered by warranty.

\*<sup>1</sup> : Inspect drive belt tensioner, idler and alternator pulley and if necessary correct or replace.

\*<sup>2</sup> : Check the engine oil level and leak every 500 km (350 miles) or before starting a long trip.

\*<sup>3</sup> : If good quality gasolines meet Europe Fuel standards (EN228) or equivalents including fuel additives is not available, one bottle of additive is recommended. Additives are available from your authorized HYUNDAI dealer along with information on how to use them. Do not mix other additives.

\*<sup>4</sup> : For your convenience, it can be replaced prior to it's interval when you do maintenance of other items.

## Normal Maintenance Schedule (for Europe) (Cont.)

MAINTENANCE ITEM	MAINTENANCE INTERVALS	Months	24	48	72	96	120	144	168	192
		Miles x 1,000	20	40	60	80	100	120	140	160
		Km x 1,000	30	60	90	120	150	180	210	240
Fuel filter *5										
Fuel lines, hoses and connections										
Cooling system		Inspect "Coolant level adjustment and leak" every day. At first, inspect 60,000 km (40,000 miles) or 48 months after that, inspect every 30,000 km (20,000 miles) or 24 months								
Engine coolant *6		At first, replace at 210,000 km (120,000 miles) or 10 years : after that, replace every 30,000 km (20,000 miles) or 24 months *4								
Valve clearance *7										
Battery condition										
Brake lines, hoses and connections										
Parking brake										

I : Inspect and if necessary, adjust, correct, clean or replace.

R : Replace or change.

\*4 : For your convenience, it can be replaced prior to its interval when you do maintenance of other items.

\*5 : The fuel filter is considered to be maintenance free but periodic inspection is recommended for this maintenance schedule depends on fuel quality. If there are some important matters like fuel flow restriction, surging, loss of power, hard starting problem etc, replace the fuel filter immediately regardless of maintenance schedule and consult an authorized HYUNDAI dealer for details.

\*6 : When adding coolant, use only deionized water or soft water for your vehicle and never mix hard water in the coolant filled at the factory. An improper coolant mixture can result in serious malfunction or engine damage.

\*7 : Inspect for excessive valve noise and/or engine vibration and adjust if necessary. We recommend that the system be checked by an authorized HYUNDAI dealer.

### Normal Maintenance Schedule (for Europe) (Cont.)

MAINTENANCE ITEM	MAINTENANCE INTERVALS		24	48	72	96	120	144	168	192
	Months									
	Miles x 1,000		20	40	60	80	100	120	140	160
	Km x 1,000		30	60	90	120	150	180	210	240
Brake/clutch fluid			R	R	R	R	R	R	R	R
Disc brakes and pads			I	I	I	I	I	I	I	I
Steering gear rack, linkage and boots			I	I	I	I	I	I	I	I
Driveshaft and boots			I	I	I	I	I	I	I	I
Tire (pressure & tread wear)			I	I	I	I	I	I	I	I
Front suspension ball joints			I	I	I	I	I	I	I	I
Air conditioner refrigerant			I	I	I	I	I	I	I	I
Air conditioner compressor			I	I	I	I	I	I	I	I
Climate control air filter			R	R	R	R	R	R	R	R
Manual transmission fluid <sup>*8</sup>				I		I		I		I
Exhaust system			I	I	I	I	I	I	I	I

I : Inspect and if necessary, adjust, correct, clean or replace.

R : Replace or change.

\*8 : Manual transmission fluid should be changed anytime they have been submerged in water.

## Maintenance Under Severe Usage and Low Mileage Conditions (for Europe)

The following items must be serviced more frequently on cars mainly used under severe and low mileage driving conditions. Refer to the chart below for the appropriate maintenance intervals.

R : Replace I : Inspect and if necessary, adjust, correct, clean or replace

Maintenance item	Maintenance operation	Maintenance intervals	Driving condition
Engine oil and engine oil filter	R	Replace every 5,000 km (3,000 miles) or 6 months	A, B, C, D, E, F, G, H, I, J, K
Air cleaner filter	R	Replace more frequently depending on the condition	C, E
Spark plugs	R	Replace more frequently depending on the condition	A, B, G, F, H, I, K
Steering gear rack, linkage and boots	I	Inspect more frequently depending on the condition	C, D, E, F, G
Front suspension ball joints	I	Inspect more frequently depending on the condition	C, D, E, F, G
Disc brakes and pads, calipers and rotors	I	Inspect more frequently depending on the condition	C, D, E, G, H
Parking brake	I	Inspect more frequently depending on the condition	C, D, G, H
Driveshaft and boots	I	Inspect more frequently depending on the condition	C, D, E, F, G, H, I

## Maintenance

Maintenance item	Maintenance operation	Maintenance intervals	Driving condition
Climate control air filter	R	Replace more frequently depending on the condition	C, E, G
Manual transmission fluid	R	Every 120,000 km (80,000 miles)	C, D, F, G, H, I, J

### Severe driving conditions

A : Repeatedly driving short distance of less than 8 km (5 miles) in normal temperature or less than 16 km (10 miles) in freezing temperature

B : Extensive engine idling or low speed driving for long distances

C : Driving on rough, dusty, muddy, unpaved, graveled or salt spread roads

D : Driving in areas using salt or other corrosive materials or in very cold weather

E : Driving in the heavy dust condition

F : More than 50% driving in heavy city traffic during hot weather above 32°C (90°F)

G : Driving on uphill, downhill, or mountain roads repeatedly

H : Towing a trailer, or using a camper or roof rack

I : Driving as patrol car, taxi, commercial car or vehicle towing

J : Driving over 170 km/h (106 mile/h)

K : Frequently driving in stop-and-go conditions and under 15,000 km per year.

## Normal Maintenance Schedule (except Europe)

MAINTENANCE ITEM	MAINTENANCE INTERVALS	Months	12	24	36	48	60	72	84	96
	Miles x 1,000	10	20	30	40	50	60	70	80	
	Km x 1,000	15	30	45	60	75	90	105	120	
Drive belts *1			I		I		I		I	
Engine oil and engine oil filter ** *2		Replace every 10,000 km (6,000 miles) or 12 months								
Fuel additives *3		Add every 10,000 km (6,000 miles) or 12 months								
Intercooler, in/out hose, air intake hose		Inspect every 10,000 km (6,000 miles)								
Air cleaner filter	Except Middle East *4	I	I	R	I	I	R	I	I	
	For Middle East *4	R	R	R	R	R	R	R	R	
Spark plugs		Replace every 75,000 km (50,000 miles) *5 or 60 months								
Vapor hose and fuel filler cap					I					I
Fuel tank air filter			I			R		I		R

I : Inspect and if necessary, adjust, correct, clean or replace.

R : Replace or change.

\*\* : The engine oil level should be checked regularly and maintained properly. Operating with an insufficient amount of oil can damage the engine, and such damage is not covered by warranty.

\*1 : Inspect drive belt tensioner, idler and alternator pulley and if necessary correct or replace.

\*2 : Check the engine oil level and leak every 500 km (350 miles) or before starting a long trip.

\*3 : If good quality gasolines meet Europe Fuel standards (EN228) or equivalents including fuel additives is not available, one bottle of additive is recommended. Additives are available from your authorized HYUNDAI dealer along with information on how to use them. Do not mix other additives.

\*4 : Middle East includes India, Iran, Libya, Algeria, Sudan, Morocco, Tunisia and Egypt.

\*5 : For your convenience, it can be replaced prior to it's interval when you do maintenance of other items.

### Normal Maintenance Schedule (except Europe) (Cont.)

MAINTENANCE ITEM	MAINTENANCE INTERVALS	Months	12	24	36	48	60	72	84	96
	Miles x 1,000	10	20	30	40	50	60	70	80	
	Km x 1,000	15	30	45	60	75	90	105	120	
Fuel filter <sup>*6</sup>			I			R		I		R
Fuel lines, hoses and connections						I				I
Cooling system	Inspect "Coolant level adjustment and leak" every day. At first, inspect 60,000 km (40,000 miles) or 48 months after that, inspect every 30,000 km (20,000 miles) or 24 months									
Engine coolant <sup>*7</sup>	At first, replace at 200,000 km (120,000 miles) or 120 months : after that, replace every 40,000 km (25,000 miles) or 24 months <sup>*5</sup>									
Valve clearance <sup>*8</sup>								I		
Battery condition		I	I	I	I	I	I	I	I	I
Brake lines, hoses and connections		I	I	I	I	I	I	I	I	I
Parking brake		I	I	I	I	I	I	I	I	I

I : Inspect and if necessary, adjust, correct, clean or replace.

R : Replace or change.

<sup>\*5</sup> : For your convenience, it can be replaced prior to it's interval when you do maintenance of other items.

<sup>\*6</sup> : The fuel filter is considered to be maintenance free but periodic inspection is recommended for this maintenance schedule depends on fuel quality. If there are some important matters like fuel flow restriction, surging, loss of power, hard starting problem etc, replace the fuel filter immediately regardless of maintenance schedule. We recommend that you consult an authorized HYUNDAI dealer for details.

<sup>\*7</sup> : When adding coolant, use only deionized water or soft water for your vehicle and never mix hard water in the coolant filled at the factory. An improper coolant mixture can result in serious malfunction or engine damage. For your convenience, it can be replaced prior to it's interval when you do maintenance of other items.

<sup>\*8</sup> : Inspect for excessive valve noise and/or engine vibration and adjust if necessary. We recommend that the system be checked by an authorized HYUNDAI dealer.



## Normal Maintenance Schedule (except Europe) (Cont.)

MAINTENANCE ITEM	MAINTENANCE INTERVALS	Months	12	24	36	48	60	72	84	96
		Miles x 1,000	10	20	30	40	50	60	70	80
		Km x 1,000	15	30	45	60	75	90	105	120
Brake/clutch fluid			I	I	I	I	I	I	I	I
Disc brakes and pads			I	I	I	I	I	I	I	I
Steering gear rack, linkage and boots			I	I	I	I	I	I	I	I
Driveshaft and boots				I		I		I		I
Tire (pressure & tread wear)			I	I	I	I	I	I	I	I
Front suspension ball joints			I	I	I	I	I	I	I	I
Air conditioner refrigerant			I	I	I	I	I	I	I	I
Air conditioner compressor			I	I	I	I	I	I	I	I
Climate control air filter			R	R	R	R	R	R	R	R
Manual transmission fluid <sup>*9</sup>						I				I
Exhaust system				I		I		I		I

I : Inspect and if necessary, adjust, correct, clean or replace.

R : Replace or change.

\*9 : Manual transmission fluid should be changed anytime they have been submerged in water.

### Maintenance Under Severe Usage and Low Mileage Conditions (except Europe)

The following items must be serviced more frequently on cars mainly used under severe driving conditions.

Refer to the chart below for the appropriate maintenance intervals.

R : Replace    I : Inspect and if necessary, adjust, correct, clean or replace

Maintenance item	Maintenance operation	Maintenance intervals	Driving condition
Engine oil and engine oil filter	R	5,000 km (3,000 miles) or 6 months	A, B, C, D, E, F, G, H, I, J, K
Air cleaner filter	R	Replace more frequently depending on the condition	C, E
Spark plugs	R	Replace more frequently depending on the condition	A, B, G, F, H, I, K
Steering gear rack, linkage and boots	I	Inspect more frequently depending on the condition	C, D, E, F, G
Front suspension ball joints	I	Inspect more frequently depending on the condition	C, D, E, F, G
Disc brakes and pads, calipers and rotors	I	Inspect more frequently depending on the condition	C, D, E, G, H
Parking brake	I	Inspect more frequently depending on the condition	C, D, G, H

Maintenance item	Maintenance operation	Maintenance intervals	Driving condition
Driveshaft and boots	I	Inspect more frequently depending on the condition	C, D, E, F, G, H, I, J
Climate control air filter	R	Replace more frequently depending on the condition	C, E, G
Manual transmission fluid	R	Every 120,000 km (80,000 miles)	C, D, E, F, G, H, I, J

### Severe driving conditions

- A : Repeatedly driving short distance of less than 8 km (5 miles) in normal temperature or less than 16 km (10 miles) in freezing temperature
- B : Extensive engine idling or low speed driving for long distances
- C : Driving on rough, dusty, muddy, unpaved, graveled or salt spread roads
- D : Driving in areas using salt or other corrosive materials or in very cold weather

- E : Driving in the heavy dust condition
- F : More than 50% driving in heavy city traffic during hot weather above 32°C (90°F)
- G : Driving on uphill, downhill, or mountain roads repeatedly
- H : Towing a trailer, or using a camper or roof rack
- I : Driving as patrol car, taxi, commercial car or vehicle towing
- J : Driving over 170 km/h (106 mile/h)
- K : Frequently driving in stop-and-go conditions

### EXPLANATION OF SCHEDULED MAINTENANCE ITEMS

#### Engine oil and filter

The engine oil and filter should be changed at the intervals specified in the maintenance schedule. If the vehicle is being driven in severe conditions, more frequent oil and filter changes are required.

#### Drive belts

Inspect all drive belts for evidence of cuts, cracks, excessive wear or oil saturation and replace if necessary. Drive belts should be checked periodically for proper tension and adjusted as necessary.



#### CAUTION

**When you are inspecting the belt, place the ignition switch to the LOCK/OFF or ACC position.**

#### Fuel filter

A clogged-up fuel filter may limit the vehicle driving speed, damage the emission system, and cause the hard starting. When a considerable amount of foreign substances are accumulated in the fuel tank, the fuel filter should be replaced.

Upon installing a new fuel filter, operate the diesel engine for several minutes, and check the connections for any leakages. We recommend you to have the fuel filter replaced by an authorized HYUNDAI dealer.

#### Fuel lines, fuel hoses and connections

Check the fuel lines, fuel hoses and connections for leakage and damage. We recommend that the fuel lines, fuel hoses and connections be replaced by an authorized HYUNDAI dealer.

#### Vapor hose and fuel filler cap

The vapor hose and fuel filler cap should be inspected at those intervals specified in the maintenance schedule. Make sure that a new vapor hose or fuel filler cap is correctly replaced.

#### Air cleaner filter

We recommend that the air cleaner filter be replaced by an authorized HYUNDAI dealer.

#### Spark plugs

Make sure to install new spark plugs of the correct heat range.



#### WARNING

**Do not disconnect and inspect spark plugs when the engine is hot. You may burn yourself.**

#### Cooling system

Check the cooling system parts, such as radiator, coolant reservoir, hoses and connections for leakage and damage. Replace any damaged parts.

### Engine coolant

The coolant should be changed at the intervals specified in the maintenance schedule.

### Valve clearance

Inspect excessive valve noise and/or engine vibration and adjust if necessary. We recommend that the system be serviced by an authorized HYUNDAI dealer.

### Manual transmission fluid

Inspect the manual transmission fluid according to the maintenance schedule.

### Brake hoses and lines

Visually check for proper installation, chafing, cracks, deterioration and any leakage. Replace any deteriorated or damaged parts immediately.

### Brake/Clutch fluid

Check the brake/clutch fluid level in the brake fluid reservoir. The level should be between “MIN” and “MAX” marks on the side of the reservoir. Use only hydraulic brake fluid conforming to DOT 3 or DOT 4 specification.

### Parking brake

Inspect the parking brake system including the parking brake lever and cables.

### Brake pads, calipers and rotors

Check the pads for excessive wear, discs for run out and wear, and calipers for fluid leakage.

For more information on checking the pads or lining wear limit, refer to the HYUNDAI web site.

(<http://service.hyundai-motor.com>)

### Suspension mounting bolts

Check the suspension connections for looseness or damage. Retighten to the specified torque.

### Steering gear box, linkage & boots/lower arm ball joint

With the vehicle stopped and engine off, check for excessive free-play in the steering wheel.

Check the linkage for bends or damage. Check the dust boots and ball joints for deterioration, cracks, or damage. Replace any damaged parts.

### Drive shafts and boots

Check the drive shafts, boots and clamps for cracks, deterioration, or damage. Replace any damaged parts and, if necessary, repack the grease.

### Air conditioning refrigerant/compressor

Check the air conditioning lines and connections for leakage and damage.

### ENGINE OIL

#### Checking the engine oil level

1. Follow all of the oil manufacturer's precautions.
2. Be sure the vehicle is on level ground.
3. Start the engine and allow it to reach normal operating temperature.
4. Turn the engine off and wait for a few minutes (about 5 minutes) for the oil to return to the oil pan.
5. Pull the dipstick out, wipe it clean, and re-insert it fully.



6. Pull the dipstick out again and check the level. The level should be between F (Full) and L (Low).

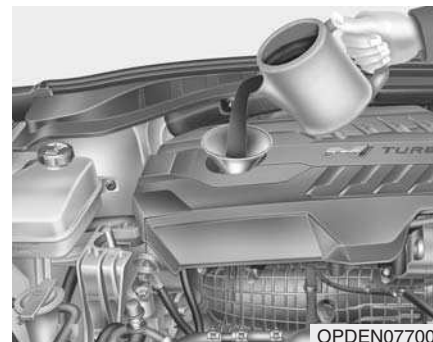

7. If it is near or at L, add enough oil to bring the level to F.

Use only the specified engine oil.  
**(Refer to “Recommended lubricants and capacities” in chapter 8.)**

#### WARNING

##### Radiator hose

**Be very careful not to touch the radiator hose when checking or adding engine oil as it may be hot enough to burn you.**

### NOTICE

To prevent damage to your engine:

- Do not overfill with engine oil. Add oil in small quantities and recheck level to ensure engine is not overfilled.
- Do not spill engine oil when adding or changing engine oil. Use a funnel to help prevent oil from being spilled on engine components. Wipe off spilled oil immediately.

### Checking the engine oil and filter



We recommend that the engine oil and filter be replaced by an authorized HYUNDAI dealer.

### ⚠ WARNING

Used engine oil may cause irritation or cancer of the skin if left in contact with the skin for prolonged periods of time. Used engine oil contains chemicals that have caused cancer in laboratory animals. Always protect your skin by washing your hands thoroughly with soap and warm water as soon as possible after handling used oil.

## ENGINE COOLANT

The high-pressure cooling system has a reservoir filled with year-round antifreeze coolant. The reservoir is filled at the factory.

Check the antifreeze protection and coolant concentration level at least once a year, at the beginning of the winter season, and before traveling to a colder climate.

### NOTICE

- **When the engine overheats from low engine coolant, suddenly adding engine coolant may cause cracks in the engine. To prevent damage, add engine coolant slowly in small quantities.**
- **Do not drive with no engine coolant. It may cause water pump failure and engine seizure, etc.**

### Checking the engine coolant level

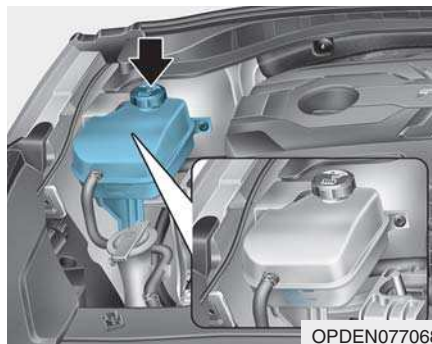

Check the condition and connections of all cooling system hoses and heater hoses. Replace any swollen or deteriorated hoses.

The coolant level should be filled between MAX and MIN (or F (Full) and L (Low)) marks on the side of the coolant reservoir when the engine is cool.

If the coolant level is low, add enough distilled (deionized) water. Bring the level to MAX (or F (Full)) but do not overfill.

If frequent additions are required, we recommend that the system be inspected by an authorized HYUNDAI dealer.

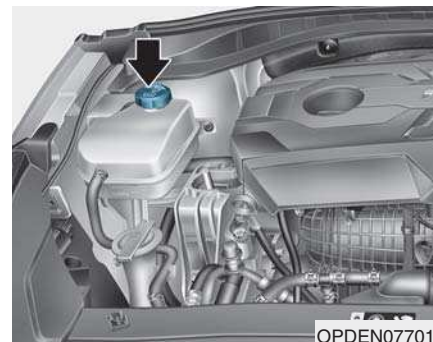

### ⚠ WARNING



**Never remove the coolant cap or the drain plug while the engine and radiator are hot. Hot coolant and steam may blow out under pressure, causing serious injury.**

**(Continued)**



**(Continued)**

Turn the engine off and wait until the engine cools down. Use extreme care when removing the coolant cap. Wrap a thick towel around it, and turn it counterclockwise slowly to the first stop. Step back while the pressure is released from the cooling system. When you are sure all the pressure has been released, press down on the cap, using a thick towel, and continue turning counterclockwise to remove it.

 **WARNING**

The electric motor for the cooling fan may continue to operate or start up when the engine is not running and can cause serious injury.

Keep hands, clothing and tools away from the rotating fan blades of the cooling fan.

The electric motor for the cooling fan is controlled by engine coolant temperature, refrigerant pressure and vehicle speed. As the engine coolant temperature decreases, the electric motor will automatically shut off. This is a normal condition. If your vehicle is equipped with GDI, the electric motor for the cooling fan may begin to operate at any time and continue to operate until you disconnect the negative battery cable.

**Recommended engine coolant**

- When adding coolant, use only distilled (deionized) water for your vehicle and never mix hard water in the coolant filled at the factory. An incorrect coolant mixture can result in serious malfunction or engine damage.
- The engine in your vehicle has aluminum engine parts and must be protected by an ethylene-glycol with phosphate based coolant to prevent corrosion and freezing.
- DO NOT USE alcohol or methanol coolant or mix them with the specified coolant.

- Do not use a solution that contains more than 60% antifreeze or less than 35% antifreeze, which would reduce the effectiveness of the solution.

For mixture percentage, refer to the following table.

Ambient Temperature	Mixture Percentage (volume)	
	Antifreeze	Water
-15°C (5°F)	35	65
-25°C (-13°F)	40	60
-35°C (-31°F)	50	50
-45°C (-49°F)	60	40

**i Information**

If in doubt about the mix ratio, a 50% water and 50% antifreeze mix is the easiest to mix together as it will be the same quantity of each. It is suitable to use for most temperature ranges of -35°C (-31°F) and higher.

**⚠ WARNING**

Make sure the coolant cap is properly closed after refilling coolant. Otherwise the engine could be overheated while driving.

■ Engine room front view

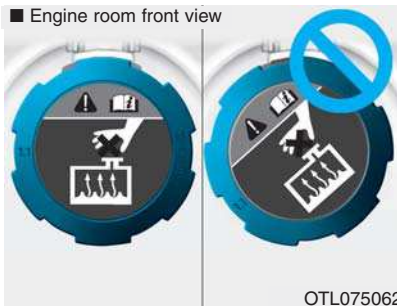

OTL075062

1. Check if the coolant cap label is straight In front.

(Continued)

(Continued)



OPDE076071

2. Make sure that the tiny protrusions inside the coolant cap is securely interlocked.

### Changing the engine coolant

We recommend that coolant be changed by an authorized HYUNDAI dealer according to the Maintenance Schedule at the beginning of this chapter.

**NOTICE**

To prevent damage to engine parts, put a thick towel around the engine coolant cap before refilling the coolant to prevent the coolant from overflowing into engine parts, such as the alternator.

## BRAKE/CLUTCH FLUID

### Checking the brake/clutch fluid level

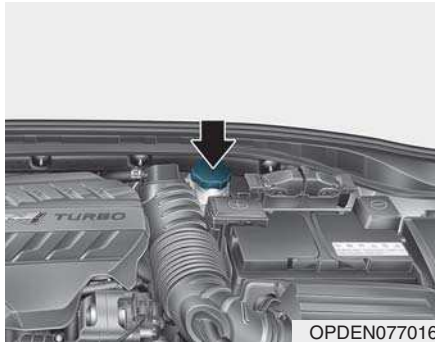

Check the fluid level in the reservoir periodically. The fluid level should be between MAX and MIN marks on the side of the reservoir.

Before removing the reservoir cap and adding brake/clutch fluid, clean the area around the reservoir cap thoroughly to prevent brake/clutch fluid contamination.

If the level is low, add fluid to the MAX level. The level will fall with accumulated mileage. This is a normal condition associated with the wear of the brake linings.

If the fluid level is excessively low, we recommend that the system be checked by an authorized HYUNDAI dealer.

#### **i** Information

Use only the specified brake/clutch fluid. Refer to “Recommended lubricants and capacities” in chapter 8.

#### **i** Information

Before removing the brake/clutch filler cap, read the warning on the cap.

#### **i** Information

Clean the filler cap before removing. Use only DOT3 or DOT4 brake/clutch fluid from a sealed container.

#### **!** WARNING

If the brake/clutch system requires frequent additions of fluid this could indicate a leak in the brake/clutch system. We recommend that the vehicle be inspected by an authorized HYUNDAI dealer.

#### **!** WARNING

Do not allow brake/clutch fluid to come in contact with your eyes. If brake/clutch fluid comes in contact with your eyes, flush your eyes with clean water for at least 15 minutes and get immediate medical attention.

#### **NOTICE**

- Do not allow brake/clutch fluid to contact the vehicle's body paint, as paint damage will result.
- Brake/clutch fluid, which has been exposed to open air for an extended time should never be used as its quality cannot be guaranteed. It should be disposed of properly.
- Don't put in the wrong kind of fluid. A few drops of mineral-based oil, such as engine oil, in your brake/clutch system can damage system parts.

## WASHER FLUID

### Checking the washer fluid level

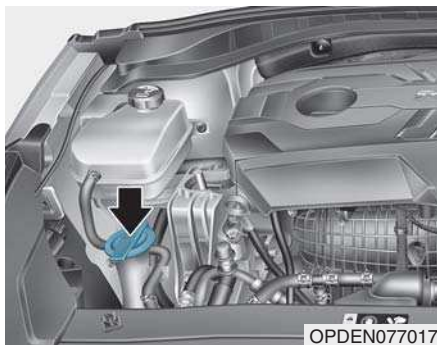

Check the fluid level in the washer fluid reservoir and add fluid if necessary. Plain water may be used if washer fluid is not available. However, use washer solvent with antifreeze characteristics in cold climates to prevent freezing.

### ⚠ WARNING

To prevent serious injury or death, take the following safety precautions when using washer fluid:

- Do not use engine coolant or antifreeze in the washer fluid reservoir. Engine coolant can severely obscure visibility when sprayed on the windshield and may cause loss of vehicle control resulting in an accident or damage to paint and body trim.
- Do not allow sparks or flames to contact the washer fluid or the washer fluid reservoir. Washer fluid may contain alcohol and can be flammable.
- Do not drink washer fluid and avoid contact with skin. Washer fluid is poisonous to humans and animals.
- Keep washer fluid away from children and animals.

## PARKING BRAKE

### Checking the parking brake

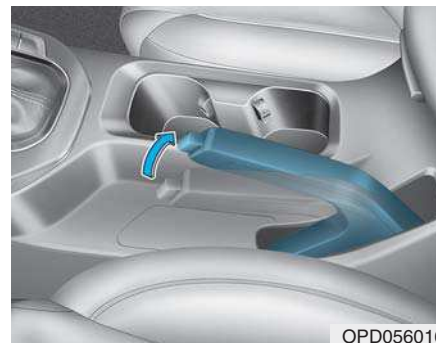

Check the stroke of the parking brake by counting the number of “clicks” heard while fully applying it from the released position. Also, the parking brake alone should securely hold the vehicle on a fairly steep grade. If the stroke is more or less than specified, we recommend that the system be serviced by an authorized HYUNDAI dealer.

**Stroke : 5~6 “clicks” at a force of 20 kg (44 lbs, 196 N).**

## AIR CLEANER

### Filter replacement

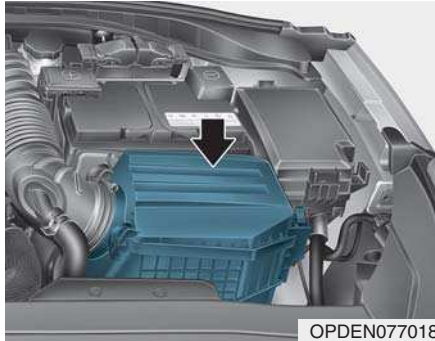

The air cleaner filter can be cleaned for inspection using compressed air. Do not attempt to wash or to rinse it, as water will damage the filter. If soiled, the air cleaner filter must be replaced.

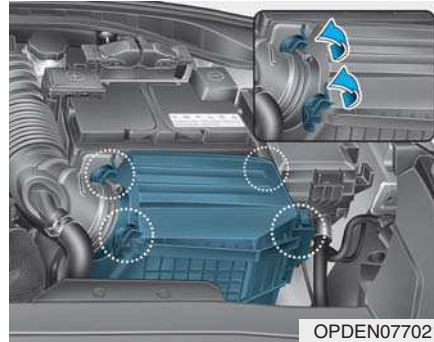

1. Loosen the air cleaner cover attaching clips and open the cover.



2. Pull out the part written PULL (1).
3. Pull out the air cleaner filter (2).
4. When installing, place the part written PULL (1) first, and then place the new air filter (2) in the original position.
5. Lock the cover with the cover attaching clips.
6. Check that the cover is firmly installed.

### **i** Information

■ Example

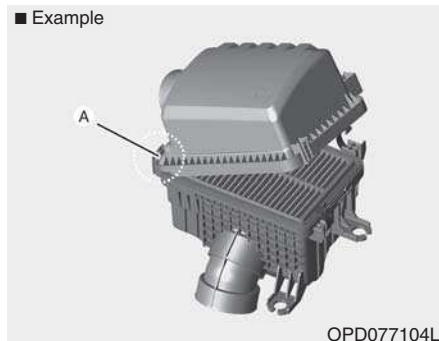

Be sure to insert the hinge (A) before locking the cover with the cover attaching clips.

### **i** Information

If the vehicle is operated in extremely dusty or sandy areas, replace the element more often than the usual recommended intervals (refer to “Maintenance Under Severe Usage Conditions” in this chapter).

#### **NOTICE**

- Do not drive with the air cleaner filter removed. This will result in excessive engine wear.
- When removing the air cleaner filter, be careful that dust or dirt does not enter the air intake, or damage may result.
- Use HYUNDAI genuine parts. Use of non-genuine parts could damage the air flow sensor.

## CLIMATE CONTROL AIR FILTER

### Filter inspection

If the vehicle is operated in the severely air-polluted cities or on dusty rough roads for a long period, it should be inspected more frequently and replaced earlier. When you, the owner, replace the climate control air filter, replace it performing the following procedure, and be careful to avoid damaging other components.

Replace the filter according to the Maintenance Schedule.

### Filter replacement

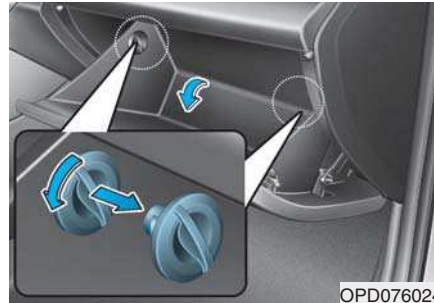

1. With the glove box open, remove the stoppers on both sides.



2. Remove the support strap (1).



3. Press and hold the lock (1) on both sides of the cover.
4. Pull out the cover (2).

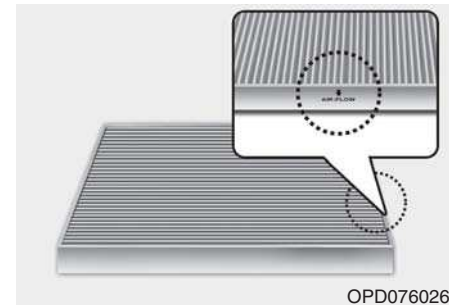

5. Replace the climate control air filter.
6. Reassemble in the reverse order of disassembly.

### NOTICE

**Install a new climate control air filter in the correct direction with the arrow symbol(↓) facing downwards, otherwise, it may be noisy and the effectiveness of the filter may be reduced.**

## WIPER BLADES

### Blade inspection

Contamination of either the windshield or the wiper blades with foreign matter can reduce the effectiveness of the windshield wipers.

Common sources of contamination are insects, tree sap, and hot wax treatments used by some commercial car washes. If the blades are not wiping properly, clean both the window and the blades with a good cleaner or mild detergent, and rinse thoroughly with clean water.

### NOTICE

**To prevent damage to the wiper blades, arms or other components, do not:**

- **Use gasoline, kerosene, paint thinner, or other solvents on or near them.**
- **Attempt to move the wipers manually.**
- **Use non-specified wiper blades.**

### **i** Information

Commercial hot waxes applied by automatic car washes have been known to make the windshield difficult to clean.

### **i** Information

Wiper blades are consumable item and normal wear of the wipers may not be covered by your vehicle warranty.



## Blade replacement

When the wipers no longer clean adequately, the blades may be worn or cracked, and require replacement.

### NOTICE

To prevent damage to the wiper arms or other components, do not attempt to move the wipers manually.

### NOTICE

The use of a non-specified wiper blade could result in wiper malfunction and failure.

### NOTICE

- In order to prevent damage to the hood and the wiper arms, the wiper arms should only be lifted when in the top wiping position.
- Always return the wiper arms to the windshield before driving.

## Front windshield wiper service positions



This vehicle has a "hidden" wiper design which means that the wipers cannot be lifted when they are in their bottom resting position.

1. Within 20 seconds of turning off the engine, move the wiper lever down and hold it to the ∇ position for about 2 seconds until the wipers move to the top wipe position.
2. At this time you can lift the wipers off the windshield.
3. Gently put the wipers back down onto the windshield.

4. Turn the wipers to any ON position to return the wipers to the bottom resting position.

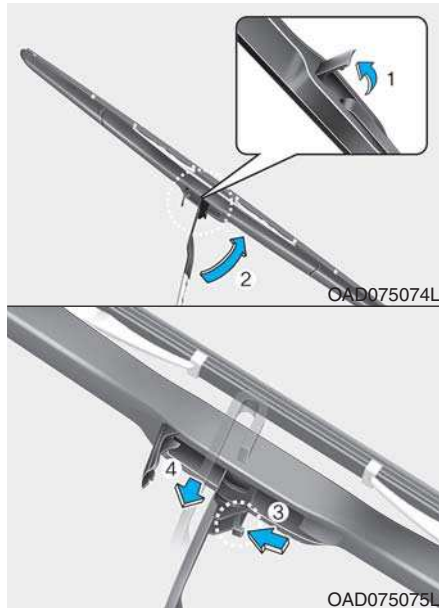

1. Lift up the wiper blade clip (1). Then lift up the wiper blade (2).
2. While pushing the lock (3), pull down the wiper blade (4).



3. Remove the wiper blade from the wiper arm (5).
4. Install a new wiper blade assembly in the reverse order of removal.
5. Return the wiper arm on the windshield.

### Rear window wiper blade

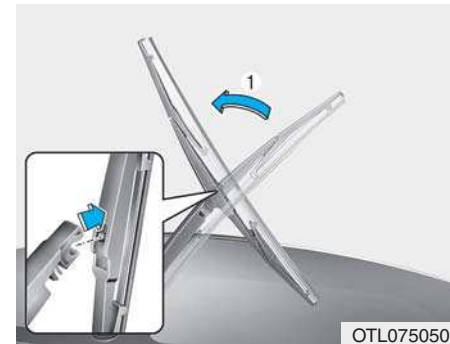

1. Raise the wiper arm and pull out the wiper blade assembly.



2. Install the new blade assembly by inserting the center part into the slot in the wiper arm until it clicks into place.
3. Make sure the blade assembly is installed firmly by trying to pull it slightly.

To prevent damage to the wiper arms or other components, we recommend that the wiper blades be replaced by an authorized HYUNDAI dealer.

## BATTERY

### WARNING

To prevent **SERIOUS INJURY** or **DEATH** to you or bystanders, always follow these precautions when working near or handling the battery:



Always read and follow instructions carefully when handling a battery.



Wear eye protection designed to protect the eyes from acid splashes.



Keep all flames, sparks, or smoking materials away from the battery.



Hydrogen is always present in battery cells, is highly combustible, and may explode if ignited.



Keep batteries out of reach of children.

(Continued)

(Continued)



Batteries contain sulfuric acid which is highly corrosive. Do not allow acid to contact your eyes, skin or clothing.

If acid gets into your eyes, flush your eyes with clean water for at least 15 minutes and get immediate medical attention. If acid gets on your skin, thoroughly wash the area. If you feel pain or a burning sensation, get medical attention immediately.

- When lifting a plastic-cased battery, excessive pressure on the case may cause battery acid to leak. Lift with a battery carrier or with your hands on opposite corners.
- Do not attempt to jump start your vehicle if your battery is frozen.

(Continued)

### (Continued)

- **NEVER** attempt to recharge the battery when the vehicle's battery cables are connected to the battery.
- The electrical ignition system works with high voltage. **NEVER** touch these components with the engine running or when the ignition switch is in the ON position.

### NOTICE

- When you do not use the vehicle for a long time in a low temperature area, disconnect the battery and keep it indoors.
- Always charge the battery fully to prevent battery case damage in low temperature areas.

### NOTICE

If you connect unauthorized electronic devices to the battery, the battery may be discharged. Never use unauthorized devices.

## For best battery service

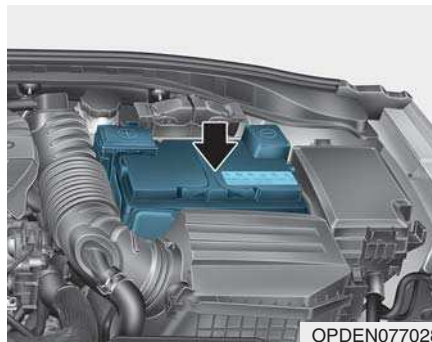

- Keep the battery securely mounted.
- Keep the battery top clean and dry.
- Keep the terminals and connections clean, tight, and coated with petroleum jelly or terminal grease.
- Rinse any spilled electrolyte from the battery immediately with a solution of water and baking soda.
- If the vehicle is not going to be used for an extended time, disconnect the battery cables.

## Battery capacity label

### Example



OLMB073072

The actual battery label in the vehicle may differ from the illustration.

1. CMF60L-BCI : The HYUNDAI model name of battery
2. 12V : The nominal voltage
3. 60Ah(20HR) : The nominal capacity (in Ampere hours)
4. 92RC : The nominal reserve capacity (in min.)
5. 550CCA : The cold-test current in amperes by SAE
6. 440A : The cold-test current in amperes by EN

## Battery recharging

### By battery charger

Your vehicle has a maintenance-free, calcium-based battery.

- If the battery becomes discharged in a short time (because, for example, the headlights or interior lights were left on while the vehicle was not in use), recharge it by slow charging (trickle) for 10 hours.
- If the battery gradually discharges because of high electric load while the vehicle is being used, recharge it at 20-30A for two hours.

### WARNING

**Always follow these instructions when recharging your vehicle's battery to avoid the risk of SERIOUS INJURY or DEATH from explosions or acid burns:**

- **Before performing maintenance or recharging the battery, turn off all accessories and place the Engine Start/Stop button to the OFF position.**
- **Keep all flames, sparks, or smoking materials away from the battery.**
- **Always work outdoors or in an area with plenty of ventilation.**
- **Wear eye protection when checking the battery during charging.**
- **The battery must be removed from the vehicle and placed in a well ventilated area.**

(Continued)

(Continued)

- **Watch the battery during charging, and stop or reduce the charging rate if the battery cells begin boiling violently.**
- **The negative battery cable must be removed first and installed last when the battery is disconnected. Disconnect the battery charger in the following order:**
  - (1) **Turn off the battery charger main switch.**
  - (2) **Unhook the negative clamp from the negative battery terminal.**
  - (3) **Unhook the positive clamp from the positive battery terminal.**
- **Always use a genuine HYUNDAI approved battery when you replace the battery.**

### CAUTION

#### AGM battery (if equipped)

- **Absorbent Glass Matt (AGM) batteries are maintenance-free and we recommend that the AGM battery be serviced by an authorized HYUNDAI dealer. For charging your AGM battery, use only fully automatic battery chargers that are specially developed for AGM batteries.**
- **When replacing the AGM battery, we recommend that you use parts for replacement from an authorized HYUNDAI dealer.**
- **Do not open or remove the cap on top of the battery. This may cause leaks of internal electrolyte that could result in severe injury.**

#### *By jump starting*

After a jump start from a good battery, drive the vehicle for 20-30 minutes before it is shutoff. The vehicle may not restart if you shut it off before the battery had a chance to adequately recharge. See “Jump Starting” in chapter 6 for more information on jump starting procedures.

#### Information



An inappropriately disposed battery can be harmful to the environment and human health.

Dispose of the battery according to your local law(s) or regulations.

#### Reset items

The following items may need to be reset after the battery has been discharged or the battery has been disconnected.

- Auto up/down window
- Sunroof
- Trip computer
- Climate control system
- Driver position memory system
- Clock
- Audio system

## TIRES AND WHEELS

### WARNING

Tire failure may cause loss of vehicle control resulting in an accident. To reduce risk of **SERIOUS INJURY** or **DEATH**, take the following precautions:

- Inspect your tires monthly for proper inflation as well as wear and damage.
- The recommended cold tire pressure for your vehicle can be found in this manual and on the tire label located on the driver's side center pillar. Always use a tire pressure gauge to measure tire pressure. Tires with too much or too little pressure wear unevenly causing poor handling.
- Check the pressure of the spare every time you check the pressure of the other tires on your vehicle.

(Continued)

(Continued)

- Replace tires that are worn, show uneven wear, or are damaged. Worn tires can cause loss of braking effectiveness, steering control, or traction.
- **ALWAYS** replace tires with the same size as each tire that was originally supplied with this vehicle. Using tires and wheels other than the recommended sizes could cause unusual handling characteristics, poor vehicle control, or negatively affect your vehicle's Anti-Lock Brake System (ABS) resulting in a serious accident.

### Information - Power Hop

When fully accelerating the vehicle from standstill, a front tire oscillation called "Power Hop" of i30 N may occur due to the high torque of engine and the characteristics of high performance tire. This is affected by road condition and temperatures. Additionally it is a normal phenomenon in powerful front-wheel drive vehicles. i30 N will act on this phenomenon with the traction control in all ESC modes with the main focus on high performance character.

### Information - Wheel nut

When the wheel is detached and reassembled frequently, replace all used wheel nuts with new wheel nuts or accessory wheel nut.

### Tire care

For proper maintenance, safety, and maximum fuel economy, you must always maintain recommended tire inflation pressures and stay within the load limits and weight distribution recommended for your vehicle.



OPD086007

All specifications (sizes and pressures) can be found on a label attached to the driver's side center pillar.

### Recommended cold tire inflation pressures

All tire pressures (including the spare) should be checked when the tires are cold. "Cold tires" means the vehicle has not been driven for at least three hours or has been driven for less than 1.6 km (1 mile).

Warm tires normally exceed recommended cold tire pressures by 28 to 41 kPa (4 to 6 psi). Do not release air from warm tires to adjust the pressure or the tires will be under-inflated. For recommended inflation pressure, refer to "Tire and Wheels" in chapter 8.

### WARNING

**Recommended pressures must be maintained for the best ride, vehicle handling, and minimum tire wear.**

**Over-inflation or under-inflation can reduce tire life, adversely affect vehicle handling, and lead to sudden tire failure that could result in loss of vehicle control resulting in an accident.**

**Severe under-inflation can lead to severe heat build-up, causing blowouts, tread separation and other tire failures that can result in the loss of vehicle control resulting in an accident. This risk is much higher on hot days and when driving for long periods at high speeds.**



 **CAUTION**

- **Under-inflation results in excessive wear, poor handling and reduced fuel economy. Wheel deformation is also possible. Keep your tire pressures at the proper levels. If a tire frequently needs refilling, we recommend it be checked by an authorized HYUNDAI dealer.**
- **Over-inflation produces a harsh ride, excessive wear at the center of the tire tread, and a greater possibility of damage from road hazards.**

### Check tire inflation pressure

Check your tires, including the spare tire, once a month or more.

#### *How to check*

Use a good quality tire pressure gauge to check tire pressure. You can not tell if your tires are properly inflated simply by looking at them. Radial tires may look properly inflated when they are under-inflated.

Remove the valve cap from the tire valve stem. Press the tire gauge firmly onto the valve to get a pressure measurement. If the cold tire inflation pressure matches the recommended pressure on the tire and loading information label, no further adjustment is necessary. If the pressure is low, add air until you reach the recommended pressure. Make sure to put the valve caps back on the valve stems. Without the valve cap, dirt or moisture could get into the valve core and cause air leakage. If a valve cap is missing, install a new one as soon as possible.

If you overfill the tire, release air by pushing on the metal stem in the center of the tire valve.

Recheck the tire pressure with the tire gauge. Be sure to put the valve caps back on the valve stems. Without the valve cap, dirt or moisture could get into the valve core and cause air leakage. If a valve cap is missing, install a new one as soon as possible.

### Tire rotation

To equalize tread wear, HYUNDAI recommends that the tires be rotated every 12,000 km (7,500 miles) or sooner if irregular wear develops.

During rotation, check the tires for correct balance.

When rotating tires, check for uneven wear and damage. Abnormal wear is usually caused by incorrect tire pressure, improper wheel alignment, out-of-balance wheels, severe braking or severe cornering. Look for bumps or bulges in the tread or side of the tire. Replace the tire if you find any of these conditions. Replace the tire if fabric or cord is visible. After rotation, be sure to bring the front and rear tire pressures to specification and check lug nut tightness (proper torque is 11~13 kgf·m [79~94 lbf·ft]).

### ■ 18 inch tire

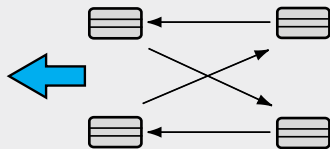

ODH073802

### ■ 19 inch tire

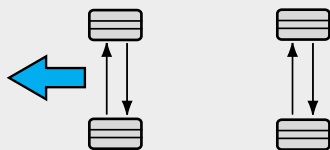

ODH073803

Disc brake pads should be inspected for wear whenever tires are rotated.

### **i** Information

The outside and inside of the unsymmetrical tire is distinguishable. When installing an unsymmetrical tire, be sure to install the side marked "outside" face the outside. If the side marked "inside" is installed on the outside, it will have a negative effect on vehicle performance.

### **!** WARNING

- Do not use the compact spare tire for tire rotation.
- Do not mix bias ply and radial ply tires under any circumstances. This may cause unusual handling characteristics that may cause loss of vehicle control resulting in an accident.

### Wheel alignment and tire balance

The wheels on your vehicle were aligned and balanced carefully at the factory to give you the longest tire life and best overall performance.

In most cases, you will not need to have your wheels aligned again. However, if you notice unusual tire wear or your vehicle pulling one way or the other, the alignment may need to be reset.

If you notice your vehicle vibrating when driving on a smooth road, your wheels may need to be rebalanced.

### **NOTICE**

Incorrect wheel weights can damage your vehicle's aluminum wheels. Use only approved wheel weights.

## Tire replacement



If the tire is worn evenly, a tread wear indicator will appear as a solid band across the tread. This shows there is less than 1.6 mm (1/16 in.) of tread left on the tire. Replace the tire when this happens.

Do not wait for the band to appear across the entire tread before replacing the tire.

### **⚠ WARNING**

**To reduce the risk of DEATH or SERIOUS INJURY:**

- Replace tires that are worn, show uneven wear, or are damaged. Worn tires can cause loss of braking effectiveness, steering control, and traction.
- Always replace tires with the same size as each tire that was originally supplied with this vehicle. Using tires and wheels other than the recommended sizes could cause unusual handling characteristics, poor vehicle control, or negatively affect your vehicle's Anti-Lock Brake System (ABS) resulting in a serious accident.

**(Continued)**

**(Continued)**

- When replacing tires (or wheels), it is recommended to replace the two front or two rear tires (or wheels) as a pair. Replacing just one tire can seriously affect your vehicle's handling. If only replacing one pair of tires, it is recommended to install the pair of new tires on the rear axle.
- Tires degrade over time, even when they are not being used. Regardless of the remaining tread, HYUNDAI recommends that tires be replaced after six (6) years of normal service.
- Heat caused by hot climates or frequent high loading conditions can accelerate the aging process. Failure to follow this warning may cause sudden tire failure, which could lead to a loss of vehicle control resulting in an accident.

### ***Compact spare tire replacement (if equipped)***

A compact spare tire has a shorter tread life than a regular size tire. Replace it when you can see the tread wear indicator bars on the tire. The replacement compact spare tire should be the same size and design tire as the one provided with your new vehicle and should be mounted on the same compact spare tire wheel. The compact spare tire is not designed to be mounted on a regular size wheel, and the compact spare tire wheel is not designed for mounting a regular size tire.

#### **WARNING**

**The original tire should be repaired or replaced as soon as possible to avoid failure of the spare and loss of vehicle control resulting in an accident. The compact spare tire is for emergency use only. Do not operate your vehicle over 80 km/h (50 mph) when using the compact spare tire.**

### **Wheel replacement**

When replacing the metal wheels for any reason, make sure the new wheels are equivalent to the original factory units in diameter, rim width and offset.

### **Tire traction**

Tire traction can be reduced if you drive on worn tires, tires that are improperly inflated or on slippery road surfaces. Tires should be replaced when tread wear indicators appear. To reduce the possibility of losing control, slow down whenever there is rain, snow or ice on the road.

### **Tire maintenance**

In addition to proper inflation, correct wheel alignment helps to decrease tire wear. If you find a tire is worn unevenly, have your dealer check the wheel alignment.

When you have new tires installed, make sure they are balanced. This will increase vehicle ride comfort and tire life. Additionally, a tire should always be rebalanced if it is removed from the wheel.

### **Tire sidewall labeling**

This information identifies and describes the fundamental characteristics of the tire and also provides the tire identification number (TIN) for safety standard certification. The TIN can be used to identify the tire in case of a recall.

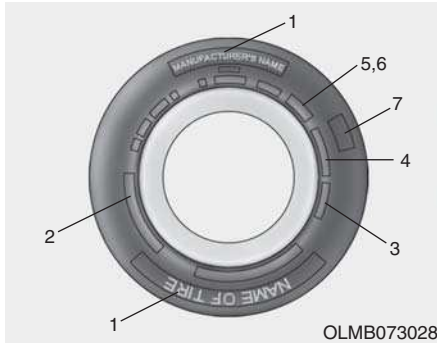

OLMB073028

### 1. **Manufacturer or brand name**

Manufacturer or brand name is shown.

### 2. **Tire size designation**

A tire's sidewall is marked with a tire size designation. You will need this information when selecting replacement tires for your car. The following explains what the letters and numbers in the tire size designation mean.

Example tire size designation:

(These numbers are provided as an example only; your tire size designator could vary depending on your vehicle.)

### **235/35R19 91Y**

235 - Tire width in millimeters.

35 - Aspect ratio. The tire's section height as a percentage of its width.

R - Tire construction code (Radial).

19 - Rim diameter in inches.

91 - Load Index, a numerical code associated with the maximum load the tire can carry.

Y - Speed Rating Symbol. See the speed rating chart in this section for additional information.

### **Wheel size designation**

Wheels are also marked with important information that you need if you ever have to replace one. The following explains what the letters and numbers in the wheel size designation mean.

Example wheel size designation:

### **8.0JX19**

8.0 - Rim width in inches.

J - Rim contour designation.

19 - Rim diameter in inches.

### Tire speed ratings

The chart below lists many of the different speed ratings currently being used for passenger vehicle tires. The speed rating is part of the tire size designation on the sidewall of the tire. This symbol corresponds to that tire's designed maximum safe operating speed.

Speed Rating Symbol	Maximum Speed
S	180 km/h (112 mph)
T	190 km/h (118 mph)
H	210 km/h (130 mph)
V	240 km/h (149 mph)
W	270km/h (168mph)
Y	300km/h (186mph)

### 3. Checking tire life (TIN : Tire Identification Number)

Any tires that are over six years old, based on the manufacturing date, (including the spare tire) should be replaced by new ones. You can find the manufacturing date on the tire sidewall (possibly on the inside of the wheel), displaying the DOT Code. The DOT Code is a series of numbers on a tire consisting of numbers and English letters. The manufacturing date is designated by the last four digits (characters) of the DOT code.

#### DOT : XXXX XXXX OOOO

The front part of the DOT shows a plant code number, tire size and tread pattern and the last four numbers indicate week and year manufactured.

For example:

DOT XXXX XXXX 1517 represents that the tire was produced in the 15th week of 2017.

### 4. Tire ply composition and material

The number of layers or plies of rubber-coated fabric in the tire. Tire manufacturers also must indicate the materials in the tire, which include steel, nylon, polyester, and others. The letter "R" means radial ply construction; the letter "D" means diagonal or bias ply construction; and the letter "B" means belted-bias ply construction.

### 5. Maximum permissible inflation pressure

This number is the greatest amount of air pressure that should be put in the tire. Do not exceed the maximum permissible inflation pressure. Refer to the Tire and Loading Information label for recommended inflation pressure.

## 6. Maximum load rating

This number indicates the maximum load in kilograms and pounds that can be carried by the tire. When replacing the tires on the vehicle, always use a tire that has the same load rating as the factory installed tire.

## 7. Uniform tire quality grading

Quality grades can be found where applicable on the tire sidewall between tread shoulder and maximum section width.

For example:

TREAD WEAR 200

TRACTION AA

TEMPERATURE A

## Tread wear

The tread wear grade is a comparative rating based on the wear rate of the tire when tested under controlled conditions on a specified government test course. For example, a tire graded 150 would wear one-and-a-half times (1½) as well on the government course as a tire graded 100.

The relative performance of tires depends upon the actual conditions of their use, however, and may depart significantly from the norm due to variations in driving habits, service practices and differences in road characteristics and climate.

These grades are molded on the sidewalls of passenger vehicle tires. The tires available as standard or optional equipment on your vehicle may vary with respect to grade.

## Traction - AA, A, B & C

The traction grades, from highest to lowest, are AA, A, B and C. Those grades represent the tire's ability to stop on wet pavement as measured under controlled conditions on specified government test surfaces of asphalt and concrete. A tire marked C may have poor traction performance.

### WARNING

**The traction grade assigned to this tire is based on straight-ahead braking traction tests, and does not include acceleration, cornering, hydroplaning, or peak traction characteristics.**

### Temperature - A, B & C

The temperature grades are A (the highest), B and C representing the tire's resistance to the generation of heat and its ability to dissipate heat when tested under controlled conditions on a specified indoor laboratory test wheel.

Sustained high temperature can cause the material of the tire to degenerate and reduce tire life, and excessive temperature can lead to sudden tire failure. Grades B and A represent higher levels of performance on the laboratory test wheel than the minimum required by law.

#### WARNING

The temperature grade for this tire is established for a tire that is properly inflated and not overloaded. Excessive speed, under-inflation, over-inflation, or excessive loading, either separately or in combination, can cause heat build-up and possible sudden tire failure. This may cause loss of vehicle control resulting in an accident.

### Low aspect ratio tires

A low aspect ratio tire, of which the aspect ratio is lower than 50, is designed for a sporty-look vehicle. The low aspect ratio is to optimize handling and braking. Thus, it may be uncomfortable to ride and it may generate noises, in comparison with a normal tire.

#### CAUTION

The side wall of a low aspect ratio tire is shorter than the normal one. Thus, the low-aspect wheel and tire are easily damaged. Follow the below instructions.

- When driving on a rough road or driving off a road, be careful not to damage the tires and wheels. After driving, inspect the tires and wheels.
- When passing over a pothole, speed bump, manhole, or curb stone, slowly drive the vehicle not to damage the tires and wheels.

(Continued)

#### (Continued)

- When there is an impact on a tire, inspect the tire condition. Or, contact an authorized HYUNDAI dealer.
- Inspect the tire condition and pressure every 3,000 km (1,800 miles) to prevent a tire damage.
- It is difficult to recognize a tire damage only with your eyes. When there is a slight hint of a tire damage, check and replace the tire to prevent the damage caused by air leakage.
- When a tire is damaged while driving on a rough road, off a road, or over obstacles, such as a pothole, manhole, or curb stone, your warranty does not cover the damage.
- The tire information is specified on the tire side wall.



## FUSES

### ■ Blade type



Normal



Blown

### ■ Cartridge type



Normal



Blown

### ■ Multi fuse

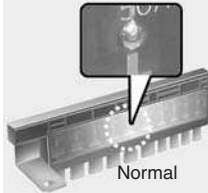

Normal

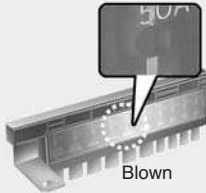

Blown



Normal



Blown

OLF074075

A vehicle's electrical system is protected from electrical overload damage by fuses.

This vehicle has 2 (or 3) fuse panels, one located in the driver's side panel bolster, the other in the engine compartment.

If any of your vehicle's lights, accessories, or controls do not work, check the appropriate circuit fuse. If a fuse has blown, the element inside the fuse will be melted or broken.

If the electrical system does not work, first check the driver's side fuse panel. Before replacing a blown fuse, turn the engine and all switches off, and then disconnect the negative battery cable. Always replace a blown fuse with one of the same rating.

If the replacement fuse blows, this indicates an electrical problem. Avoid using the system involved and immediately consult an authorized HYUNDAI dealer.

### **i** Information

Three kinds of fuses are used: blade type for lower amperage rating, cartridge type, and multi fuse for higher amperage ratings.

### **⚠** WARNING

**NEVER** replace a fuse with anything but another fuse of the same rating.

- A higher capacity fuse could cause damage and possibly cause a fire.
- Do not install a wire or aluminum foil instead of the proper fuse - even as a temporary repair. It may cause extensive wiring damage and possibly a fire.

### **NOTICE**

Do not use a screwdriver or any other metal object to remove fuses because it may cause a short circuit and damage the system.

### Instrument panel fuse replacement

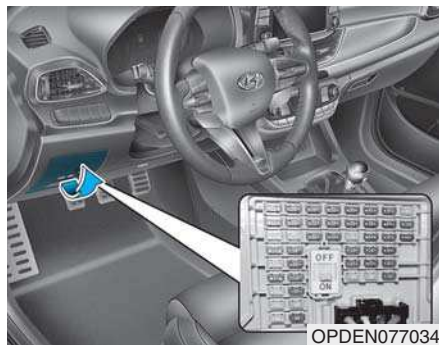

1. Turn the vehicle off.
2. Turn all other switches OFF.
3. Open the fuse panel cover.
4. Refer to the label on the inside of the fuse panel cover to locate the suspected fuse location.

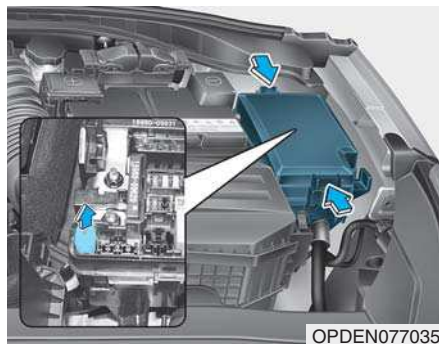

5. Pull the suspected fuse straight out. Use the removal tool provided in the engine compartment fuses panel.
6. Check the removed fuse; replace it if it is blown. Spare fuses are provided in the instrument panel fuse panels (or in the engine compartment fuse panel).
7. Push in a new fuse of the same rating, and make sure it fits tightly in the clips. If it fits loosely, consult an authorized HYUNDAI dealer.

In an emergency, if you do not have a spare fuse, use a fuse of the same rating from a circuit you may not need for operating the vehicle, such as the cigarette lighter fuse.

If the headlamps or other electrical components do not work and the fuses are undamaged, check the fuse panel in the engine compartment. If a fuse is blown, it must be replaced with the same rating.

## Fuse switch

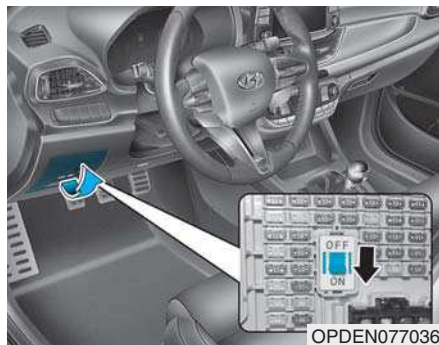

Always, place the fuse switch to the ON position.

If you move the switch to the OFF position, some items such as the audio system and digital clock must be reset and the smart key may not work properly.

## **i** Information

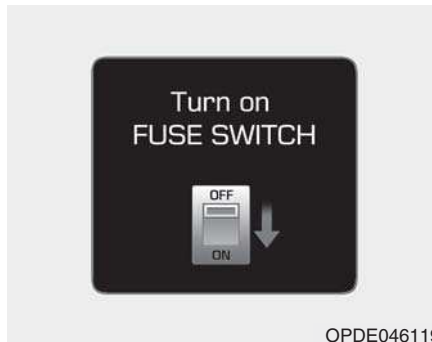

If the fuse switch is OFF, “Turn on FUSE SWITCH” message will appear.

### **NOTICE**

- **Always place the fuse switch in the ON position while driving the vehicle.**
- **Do not move the transportation fuse switch repeatedly. The fuse switch may be damaged.**

## Engine compartment panel fuse replacement

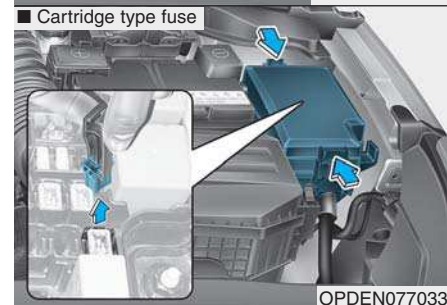
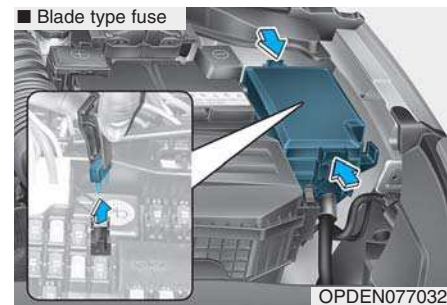

1. Turn the vehicle off.
2. Turn all other switches OFF.
3. Remove the fuse panel cover by pressing the tab and pulling up.

4. Check the removed fuse; replace it if it is blown. To remove or insert the fuse, use the fuse puller in the engine compartment fuse panel.
5. Push in a new fuse of the same rating, and make sure it fits tightly in the clips. If it fits loosely, consult an authorized HYUNDAI dealer.

### NOTICE

After checking the fuse panel in the engine compartment, securely install the fuse panel cover. You may hear a clicking sound if the cover is securely latched. If it is not securely latched, electrical failure may occur from water contact.

### Main fuse

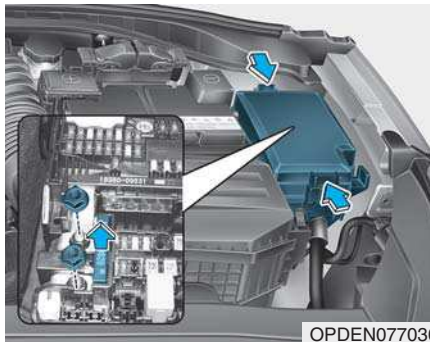

1. Turn the engine off.
2. Turn all other switches off.
3. Remove the fuse panel cover by pressing the tab and pulling it up.
4. Remove the nuts shown in the picture above.
5. Replace the fuse with a new one of the same rating.
6. Reinstall in the reverse order of removal.

### **i** Information

If the main fuse is blown, we recommend that you consult an authorized HYUNDAI dealer.

### Multi fuse

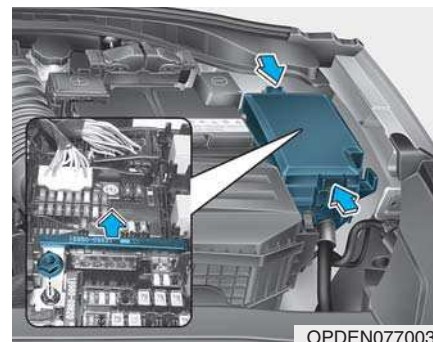

1. Turn the vehicle off.
2. Disconnect the negative battery cable.
3. Remove the fuse panel cover by pressing the tab and pulling it up.
4. Remove the nuts shown in the picture above.
5. Replace the fuse with a new one of the same rating.
6. Reinstall in the reverse order of removal.

If the multi fuse is blown, we recommend that you consult an authorized HYUNDAI dealer.

## Fuse/Relay panel description

### Driver's side fuse panel

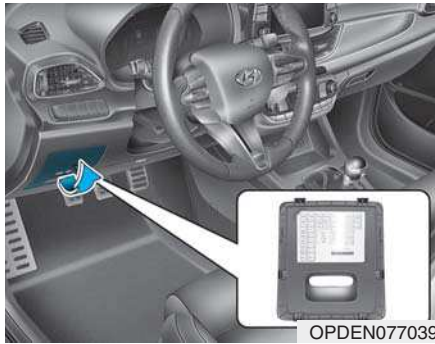

OPDEN077039

Inside the fuse/relay box covers, you can find the fuse/relay label describing fuse/relay names and ratings.





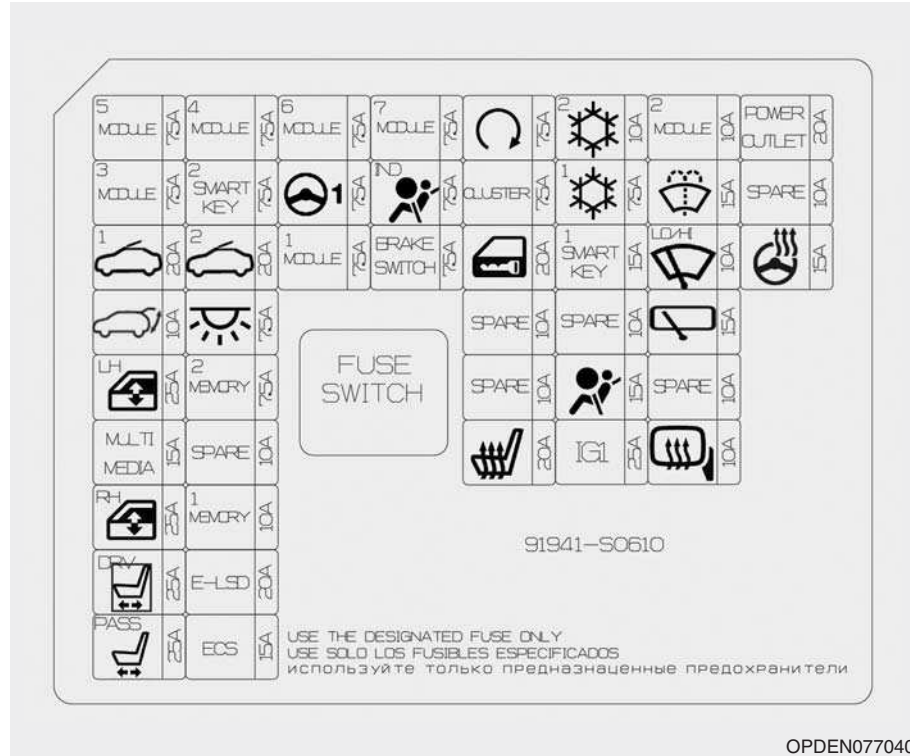

### **i** Information

Not all fuse panel descriptions in this manual may be applicable to your vehicle. It is accurate at the time of printing. When you inspect the fuse box on your vehicle, refer to the fuse box label.





OPDEN077040









### Driver's side fuse Panel

Fuse No.	Fuse Name	Symbol	Fuse Rating	Circuit Protected
F1	MODULE 5	<sup>5</sup> MODULE	7.5A	Electro Chromic Mirror, MTS E-Call Module, Audio, A/V & Navigation Head Unit, A/C Control Module, A/T Shift Lever Indicator, Console Switch RH, DC-DC Converter, Head Lamp LH/RH, Auto Head Lamp Leveling Device Module, Front Seat Warmer Control Module, Driver IMS Module
F2	MODULE 3	<sup>3</sup> MODULE	7.5A	Driver/Passenger Door Module, BCM
F3	SUNROOF 1	<sup>1</sup> 	20A	Panorama Sunroof
F4	TAILGATE		10A	Tail Gate Relay
F5	POWER WINDOW LH	<sup>LH</sup> 	25A	Power Window LH Relay, Driver/Passenger Safety Window Module, Rear Safety Window Module LH
F6	MULTIMEDIA	MULTI MEDIA	15A	Audio, A/V & Navigation Head Unit, DC-DC Converter
F7	POWER WINDOW RH	<sup>RH</sup> 	25A	Power Window RH Relay, Driver/Passenger Safety Window Module, Rear Safety Window Module RH
F8	POWER SEAT DRIVER	<sup>DRV</sup> 	25A	Driver Seat Manual Switch, Driver IMS Module
F9	POWER SEAT PASSENGER	<sup>PASS</sup> 	25A	Passenger Seat Manual Switch
F10	MODULE 4	<sup>4</sup> MODULE	7.5A	Lane Keeping Assist Module, Stop Lamp Switch, BCM, LSD ECU, ECS Unit
F11	SMART KEY 2	<sup>2</sup> SMART KEY	7.5A	Smart Key Control Module, Immobilizer Module
F12	SUNROOF 2	<sup>2</sup> 	20A	Panorama Sunroof

## Driver's side fuse Panel





Fuse No.	Fuse Name	Symbol	Fuse Rating	Circuit Protected
F13	INTERIOR LAMP		7.5A	Wireless Charger, Vanity Lamp LH/RH, Room Lamp, Overhead Console Lamp, Personal Lamp LH/RH, Rain Sensor, Ignition Key III. & Door Warning Switch, Glove Box Lamp, Luggage Lamp, Rain Sensor
F14	MEMORY 2	<sup>2</sup> MEMORY	7.5A	MTS E-Call Module
F16	MEMORY 1	<sup>1</sup> MEMORY	10A	Driver/Passenger Door Module, Driver IMS Module, BCM, A/C Control Module, Instrument Cluster, Auto Light & Photo Sensor, ICM Relay Box (Outside Mirror Folding/Unfolding Relay)
F17	E-LSD	E-LSD	20A	LSD ECU
F18	ECS	ECS	15A	ECS Unit
F19	MODULE 6	<sup>6</sup> MODULE	7.5A	Smart Key Control Module, BCM
F20	MDPS	 1	7.5A	MDPS Unit, Steering Angle Sensor
F21	MODULE 1	<sup>1</sup> MODULE	7.5A	Hazard Switch, Center Door Lock Switch, Driver/Passenger Door Module, Driver/Passenger Power Outside Mirror, Driver/Passenger Smart Key Outside Handle, Data Link Connector
F22	MODULE 7	<sup>7</sup> MODULE	7.5A	Front Seat Warmer Control Module, ESG Unit, Cooling Fan Motor, Nozzle
F23	AIRBAG INDICATOR		7.5A	Instrument Cluster, Center Door Lock Switch
F24	BRAKE SWITCH	<b>BRAKE SWITCH</b>	7.5A	Smart Key Control Module, Stop Lamp Switch

### Driver's side fuse Panel

Fuse No.	Fuse Name	Symbol	Fuse Rating	Circuit Protected
F25	START		7.5A	Smart Key Control Module, Engine Room Junction Block (RLY.4)
F26	CLUSTER	CLUSTER	7.5A	Instrument Cluster
F27	DOOR LOCK		20A	Door Lock/Unlock Relay, ICM Relay Box (Dead Lock Relay)
F30	SEAT HEATER FRONT		20A	Front Seat Warmer Control Module
F31	AIR CONDITIONER 2	<sup>2</sup> 	10A	A/C Control Module, ECM, Blower Motor, Engine Room Junction Block (RLY.10)
F32	AIR CONDITIONER 1	<sup>1</sup> 	7.5A	A/C Control Module, Engine Room Junction Block (RLY.10/11)
F33	SMART KEY 1	<sup>1</sup> SMART KEY	15A	Smart Key Control Module, Immobilizer Module
F35	AIRBAG		15A	SRS Control Module
F36	IGNITION 1	IG1	25A	PCB Block (F45/F46/F47)
F37	MODULE 2	<sup>2</sup> MODULE	10A	Wireless Charger, MTS E-Call Module, Smart Key Control Module, BCM, Audio, A/V & Navigation Head Unit, DC-DC Converter, Power Outside Mirror Switch, Engine Room Junction Block (RLY.14)
F38	WASHER		15A	Multifunction Switch
F39	WIPER	 LOHI	10A	ECM, BCM



## Driver's side fuse Panel

Fuse No.	Fuse Name	Symbol	Fuse Rating	Circuit Protected
F40	REAR WIPER		15A	Rear Wiper Relay
F42	MIRROR HEATED		10A	Driver/Passenger Power Outside Mirror, A/C Control Module
F43	POWER OUTLET	POWER OUTLET 	20A	Rear Power Outlet #2
F45	HEATED STEERING		15A	BCM

### Engine compartment fuse panel

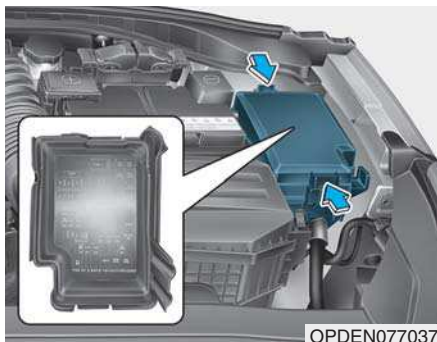





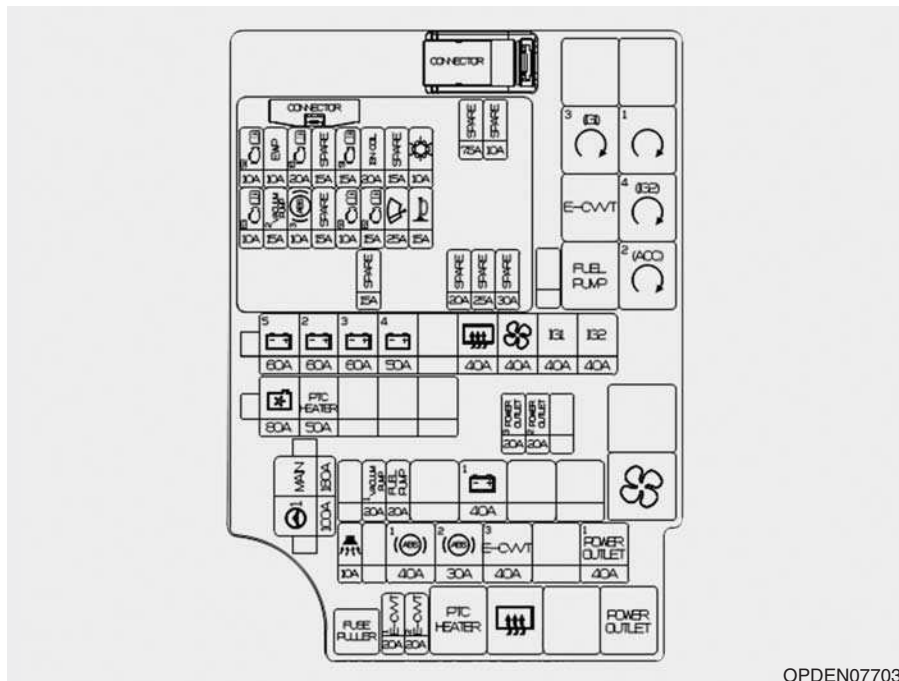

Inside the fuse/relay box covers, you can find the fuse/relay label describing fuse/relay names and ratings.

#### **i** Information









Not all fuse panel descriptions in this manual may be applicable to your vehicle. It is accurate at the time of printing. When you inspect the fuse box on your vehicle, refer to the fuse box label.







## Engine compartment fuse panel

Relay No.	Symbol	Relay Name
RLY. 3	<sup>3</sup> (IG1) 	PDM #3 (IG1) Relay
RLY. 4	<sup>1</sup> 	START Relay
RLY. 5	E-CVVT	E-CVVT Relay
RLY. 6	<sup>4</sup> (IG2) 	PDM #4 (IG2) Relay
RLY. 7	FUEL PUMP	FUEL PUMP Relay
RLY.8	<sup>2</sup> (ACC) 	PDM #2 (ACC) Relay
RLY. 10		BLOWER Relay
RLY. 11	PTC HEATER	PTC HEATER #1 Relay
RLY. 12		REAR DEFOGGER Relay
RLY. 14	POWER OUTLET	POWER OUTLET Relay

### Engine compartment fuse panel

Fuse No.	Fuse Name	Symbol	Fuse Rating	Circuit Protected
F1	MAIN	MAIN	180A	Fuse : F27, F29, F30, F33
F2	MDPS 1	 <sup>1</sup>	100A	MDPS Unit
F3	B+5	 <sup>5</sup>	60A	PCB Block (Fuse : F44, F50, F51, F52, Engine Control Relay)
F4	B+2	 <sup>2</sup>	60A	IGPM (Fuse : F30, IPS0, IPS1, IPS2)
F5	B+3	 <sup>3</sup>	60A	IGPM (IPS3, IPS4, IPS5, IPS6, IPS7, IPS8)
F6	B+4	 <sup>4</sup>	60A	IGPM (Fuse : F3, F4, F5, F7, F8, F9, F12, F17, F18)
F8	REAR HEATED		40A	RLY.12
F9	BLOWER		40A	RLY.10
F10	IGNITION 1	IG1	40A	Ignition Switch, Engine Room Junction Block (RLY.3, RLY8)
F11	IGNITION 2	IG2	40A	Ignition Switch, Engine Room Junction Block (RLY.4, RLY.6)
F12	COOLING FAN		80A	Cooling Fan Motor
F13	PTC HEATER 1	 <sup>1</sup> PTC HEATER	50A	RLY.11

## Engine compartment fuse panel

Fuse No.	Fuse Name	Symbol	Fuse Rating	Circuit Protected
F17	POWER OUTLET 3	<sup>3</sup> POWER OUTLET	20A	Rear Power Outlet
F18	POWER OUTLET 2	<sup>2</sup> POWER OUTLET	20A	Front Power Outlet
F21	VACUUM PUMP 1	<sup>1</sup> VACUUM PUMP	20A	Vacuum Pump
F22	FUEL PUMP	FUEL PUMP	20A	RLY.7
F24	B+1	<sup>1</sup> 	40A	IGPM (Leak Current Autocut Device, Fuse : F21, F24, F27, F33)
F27	BURGLAR ALARM HORN		10A	ICM Relay Box (Burglar Alarm Horn Relay)
F29	ABS 1	<sup>1</sup> 	40A	ESP Control Module
F30	ABS 2	<sup>2</sup> 	30A	ESP Control Module
F31	E-CVVT 3	<sup>3</sup> E-CVVT	40A	RLY.5
F33	POWER OUTLET 1	<sup>1</sup> POWER OUTLET	40A	RLY.14
F34	E-CVVT1	<sup>1</sup> E-CVVT	10A	ECM
F35	E-CVVT 2	<sup>2</sup> E-CVVT	20A	ECM

### Engine compartment fuse panel (Battery terminal cover)

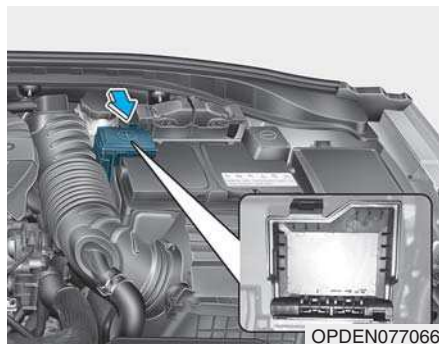

Inside the fuse/relay box cover, you can find the fuse/relay label describing fuse/relay names and ratings.

#### **i** Information

Not all fuse panel descriptions in this manual may be applicable to your vehicle; the information is accurate at the time of printing. When you inspect the fuse panel in your vehicle, refer to the fuse panel label.



#### **NOTICE**

After checking the fuse panel in the engine compartment, securely install the cover. If it is not securely latched, electrical failure may occur from water contact.

## LIGHT BULBS

Consult an authorized HYUNDAI dealer to replace most vehicle light bulbs. It is difficult to replace vehicle light bulbs because other parts of the vehicle must be removed before you can get to the bulb. This is especially true for removing the headlamp assembly to get to the bulb(s).

Removing/installing the headlamp assembly can result in damage to the vehicle.

### WARNING

**Prior to working on a light, firmly apply the parking brake, ensure that the ignition switch is in the LOCK/OFF position and turn off the lights to avoid sudden movement of the vehicle and burning your fingers or receiving an electric shock.**

### NOTICE

**Be sure to replace the burned-out bulb with one of the same wattage rating. Otherwise, it may cause damage to the fuse or electrical wiring system.**

### Information

After heavy driving rain or washing, headlamp and tail lamp lenses could appear frosty. This condition is caused by the temperature difference between the lamp inside and outside. This is similar to the condensation on your windows inside your vehicle when raining and doesn't indicate a problem with your vehicle. If the water leaks into the lamp bulb circuitry, we recommend that the system be checked by an authorized HYUNDAI dealer.

### Information

The headlamp aiming should be adjusted after an accident or after the headlamp assembly is reinstalled at an authorized HYUNDAI dealer.

### Information - Traffic Change (for Europe)

The low beam light distribution is asymmetric. If you go abroad to a country with opposite traffic direction, this asymmetric part will dazzle oncoming car driver. To prevent dazzle, ECE regulation demand several technical solutions (ex. automatic change system, adhesive sheet, down aiming). These headlamps are designed not to dazzle opposite drivers. So, you need not change your headlamps in a country with opposite traffic direction.

### Headlamp, static bending lamp, position lamp, turn signal lamp and daytime running light bulb replacement

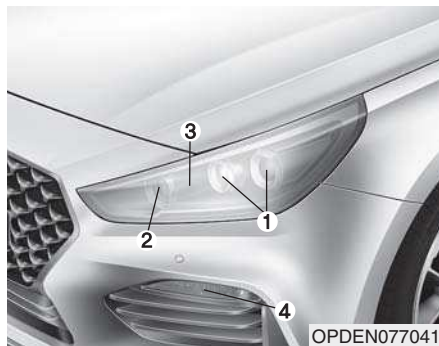

- (1) Headlamp (Low)
- (2) Headlamp (High)
- (3) Static bending light
- (4) Position lamp & Turn signal lamp & Daytime running light

### Headlamp, static bending light, position lamp, turn signal lamp and daytime running light

If the light bulb does not operate, we recommend that you have the vehicle checked by an authorized HYUNDAI dealer.

### Headlamp aiming (for Europe)

#### Headlamp aiming

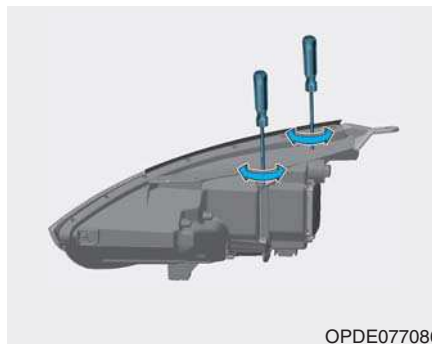

1. Inflate the tires to the specified pressure and remove any loads from the vehicle except the driver, spare tire, and tools.
2. The vehicle should be placed on a flat floor.
3. Draw vertical lines (Vertical lines passing through respective head lamp centers) and a horizontal line (Horizontal line passing through center of head lamps) on the screen.

4. With the headlamp and battery in normal condition, aim the headlamps so the brightest portion falls on the horizontal and vertical lines.
5. To aim the low beam left or right, turn the driver clockwise or counterclockwise. To aim the low beam up or down, turn the driver clockwise or counterclockwise.  
To aim the high beam up or down, turn the driver clockwise or counterclockwise.



## Aiming point

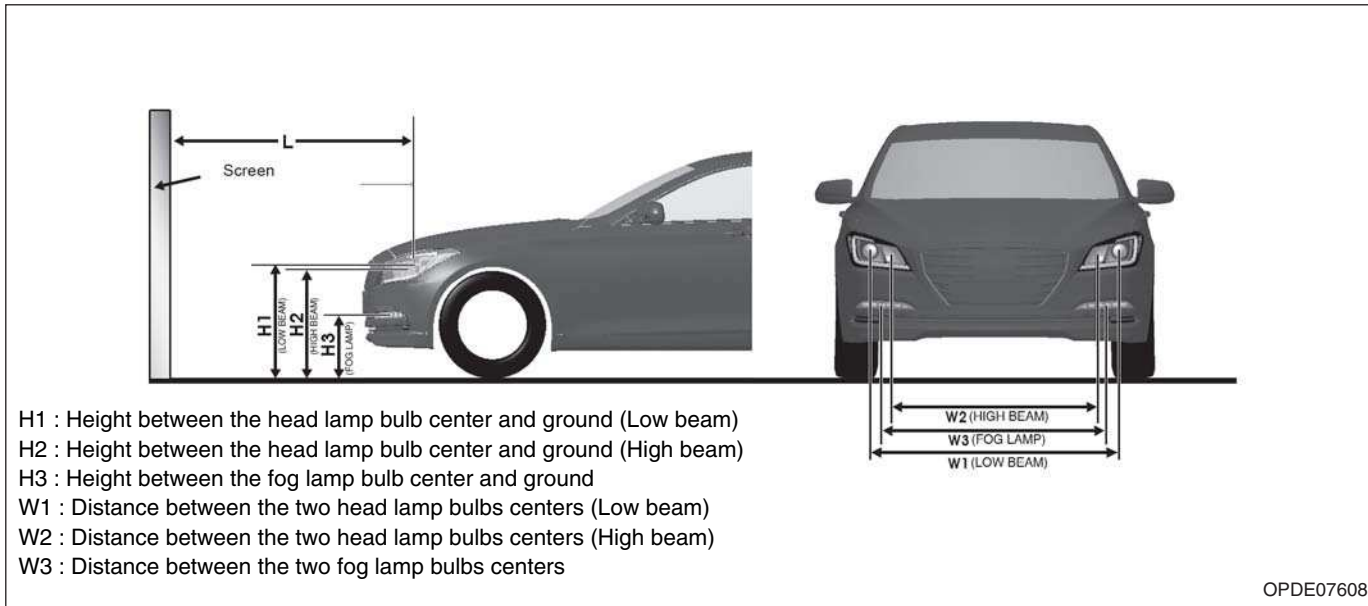

OPDE076081

Unit: mm (in)

Vehicle condition	Lamp type	H1	H2	H3	W1	W2	W3
<b>Without driver</b>	LED	677 (26.65)	631 (24.84)	344 (13.54)	1,385 (54.52)	1,114 (43.85)	1,484 (58.42)
<b>With driver</b>	LED	672 (26.45)	626 (24.64)	339 (13.34)	1,385 (54.52)	1,114 (43.85)	

### Headlamp low beam (LHD side)

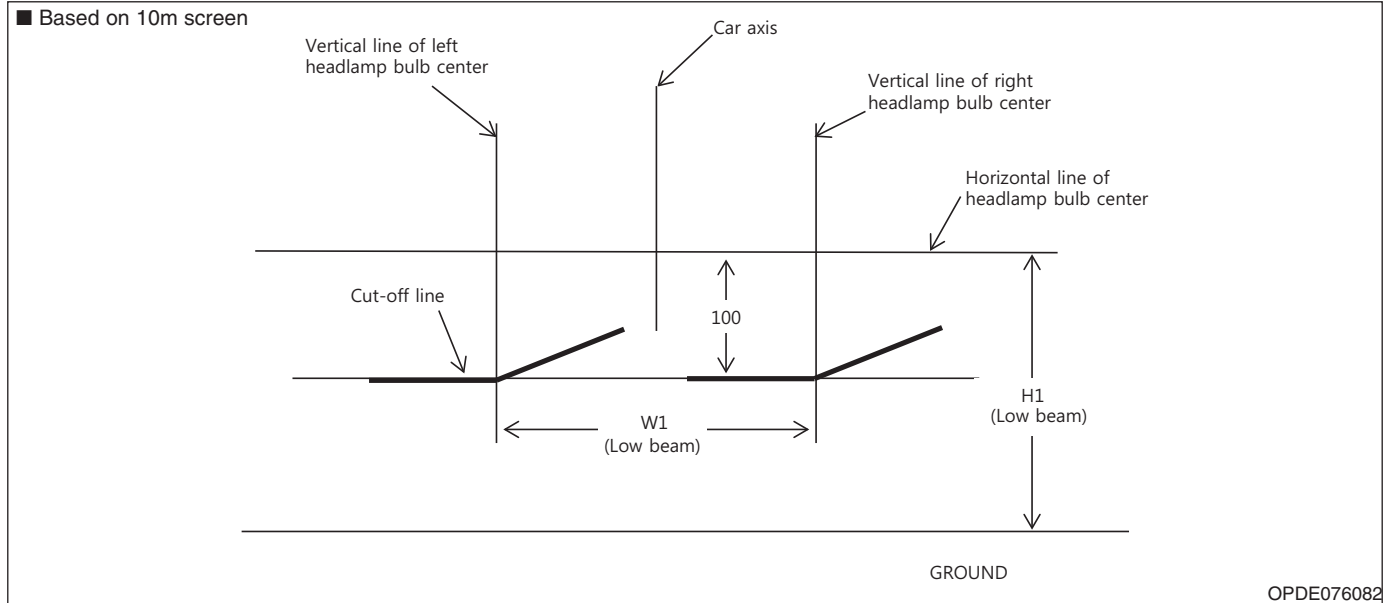

1. Turn the low beam on without driver aboard.
2. The cut-off line should be projected in the cut-off line shown in the picture.
3. When aiming the low beam, vertical aiming should be adjusted after adjusting the horizontal aiming.
4. If headlamp leveling device is equipped, adjust the head lamp leveling device switch with 0 positions.

## Headlamp low beam (RHD side)

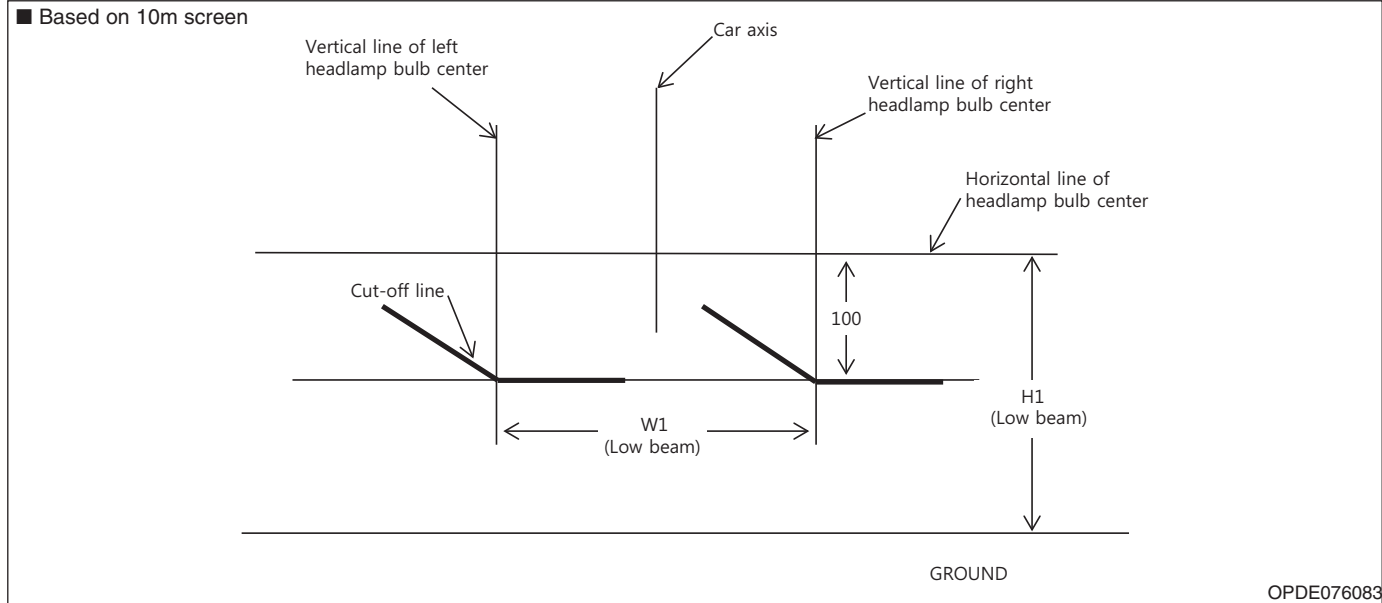

1. Turn the low beam on without driver aboard.
2. The cut-off line should be projected in the cut-off line shown in the picture.
3. When aiming the low beam, vertical aiming should be adjusted after adjusting the horizontal aiming.
4. If headlamp leveling device is equipped, adjust the head lamp leveling device switch with 0 positions.

### Side repeater lamp replacement



If the light bulb does not operate, we recommend that you have the vehicle checked by an authorized HYUNDAI dealer.

### Rear combination lamp bulb replacement

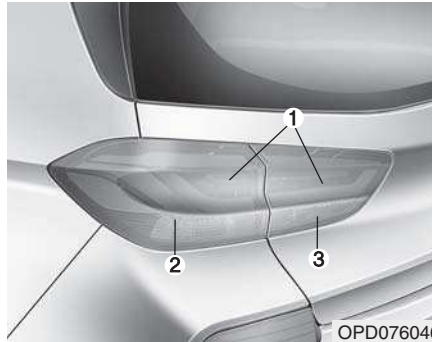

- (1) Stop/Tail lamp
- (2) Turn signal lamp
- (3) Backup lamp

#### Stop/Tail lamp

If the LED lamp does not operate, we recommend that you have the vehicle checked by an authorized HYUNDAI dealer.

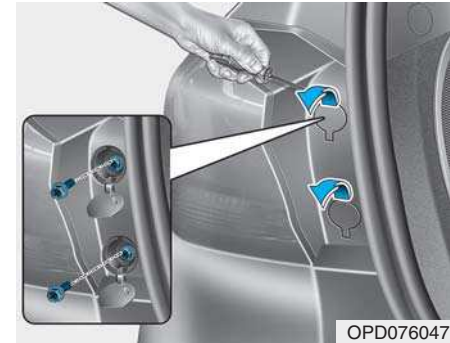

#### Turn signal lamp

- 1. Turn off the engine.
- 2. Open the tailgate.
- 3. Open the lamp assembly retaining screw covers.
- 4. Loosen the lamp assembly retaining screws with a cross-tip screwdriver.

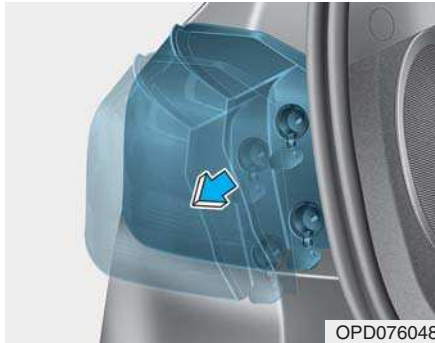

5. Remove the rear combination lamp assembly from the body of the vehicle.

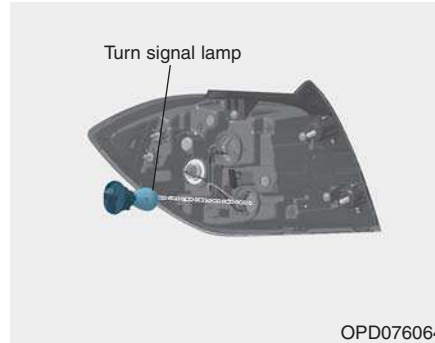

6. Remove the socket from the assembly by turning the socket counter-clockwise until the tabs on the socket align with the slots on the assembly.
7. Remove the bulb from the socket by pressing it in and rotating it counter-clockwise until the tabs on the bulb align with the slots in the socket. Pull the bulb out of the socket.
8. Insert a new bulb by inserting it into the socket and rotating it until it locks into place.
9. Install the socket in the assembly by aligning the tabs on the socket with the slots in the assembly. Push the socket into the assembly and turn the socket clockwise.
10. Reinstall the lamp assembly to the body of the vehicle



### Backup lamp

1. Turn off the engine.
2. Open the tailgate.
3. Remove the service cover using a flat-blade screwdriver.



4. Remove the bulb by pulling it straight out.
5. Insert a new bulb by inserting it into the socket and rotating it until it locks into place.
6. Install the socket into the assembly by aligning the tabs on the socket with the slots in the assembly. Push the socket into the assembly and turn the socket clockwise.
7. Reinstall the service cover.

### Rear fog lamp replacement

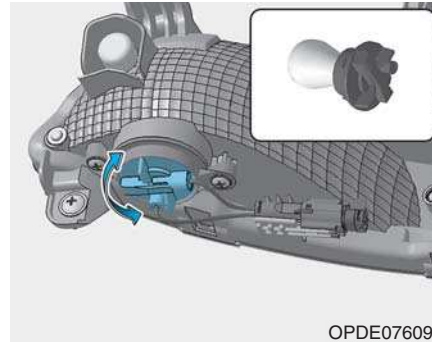

1. Loosen the pin-type retainers and screws of the rear wheel guard and then detach it from the rear bumper.
2. Reach your hand into the back of the rear bumper.
3. Remove the socket from the housing by turning the socket counter-clockwise until the tabs on the socket align with the slots of the housing.
4. Remove the bulb from the socket by pressing it in and rotating it counter-clockwise until the tabs on the bulb align with the slots in the socket. Pull the bulb out of the socket.
5. Insert a new bulb by inserting it into the socket and rotating it until it locks into place.
6. Install the socket into the housing by aligning the tabs on the socket with the slots in the housing. Push the socket into the housing and turn the socket clockwise.

## High mounted stop lamp replacement



If the high mounted stop lamp does not operate, we recommend that you contact an authorized HYUNDAI dealer.

## License plate light bulb replacement

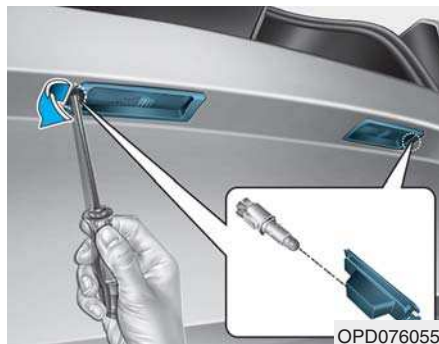

1. Using a flat-blade screwdriver, gently pry the lens cover from the lamp housing.
2. Remove the bulb by pulling it straight out.
3. Install a new bulb.
4. Reinstall in the reverse order.

## Interior light bulb replacement

### Room lamp



If the LED lamp does not operate, we recommend that you have the vehicle checked by an authorized HYUNDAI dealer.

### Map lamp, room lamp, vanity mirror lamp and luggage compartment lamp

■ Map lamp

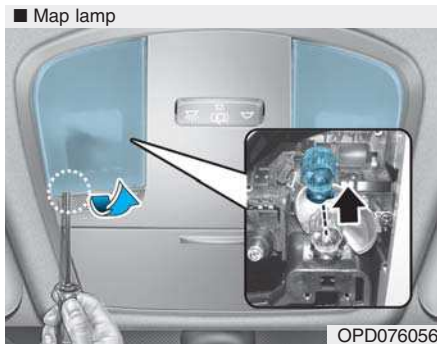

■ Room lamp - without sunroof

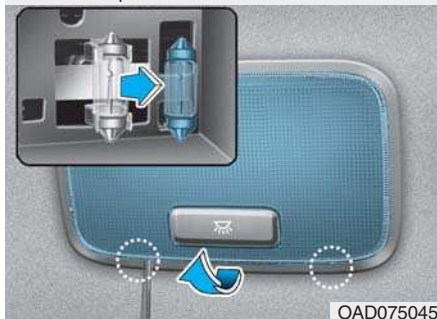

■ Vanity mirror lamp



■ Luggage compartment lamp



1. Using a flat-head screwdriver, gently pry the lens from the interior light housing.
2. Remove the bulb by pulling it straight out.
3. Install a new bulb into the socket.
4. Align the lens tabs with the interior light housing notches and snap the lens into place.

#### **NOTICE**

**Be careful not to damage the cover, tab, and plastic housing.**



## APPEARANCE CARE

### Exterior care

#### *Exterior general caution*

It is very important to follow the label directions when using any chemical cleaner or polish. Read all warning and caution statements that appear on the label.

#### *Finish maintenance*

##### Washing

To help protect your vehicle's finish from rust and deterioration, wash it thoroughly and frequently at least once a month with lukewarm or cold water.

If you use your vehicle for off-road driving, you should wash it after each off-road trip. Pay special attention to the removal of any accumulation of salt, dirt, mud, and other foreign materials. Make sure the drain holes in the lower edges of the doors and rocker panels are kept clear and clean.

Insects, tar, tree sap, bird droppings, industrial pollution and similar deposits can damage your vehicle's finish if not removed immediately.

Even prompt washing with plain water may not completely remove all these deposits.

A mild soap, safe for use on painted surfaces, may be used.

After washing, rinse the vehicle thoroughly with lukewarm or cold water. Do not allow soap to dry on the finish.

##### NOTICE

- **Do not use strong soap, chemical detergents or hot water, and do not wash the vehicle in direct sunlight or when the body of the vehicle is warm.**
- **Be careful when washing the side windows of your vehicle. Especially, with high-pressure water, water may leak through the windows and wet the interior.**
- **To prevent damage to the plastic parts and lamps, do not clean with chemical solvents or strong detergents.**

##### WARNING

#### Wet brakes

**After washing the vehicle, test the brakes while driving slowly to see if they have been affected by water. If braking performance is impaired, dry the brakes by applying them lightly while maintaining a slow forward speed.**

#### High-pressure washing

- When using high-pressure washers, make sure to maintain sufficient distance from the vehicle. Insufficient clearance or excessive pressure can lead to component damage or water penetration.
- Do not spray the camera, sensors or its surrounding area directly with a high pressure washer. Shock applied from high pressure water may cause the device to not operate normally.
- Do not bring the nozzle tip close to boots (rubber or plastic covers) or connectors as they may be damaged if they come into contact with high pressure water.



OLMB073082

### NOTICE

- **Water washing in the engine compartment including high pressure water washing may cause the failure of electrical circuits located in the engine compartment.**
- **Never allow water or other liquids to come in contact with electrical/electronic components inside the vehicle as this may damage them.**

### Waxing

A good coat of wax is a barrier between your paint and contaminants. Keeping a good coat of wax on your vehicle will help protect it.

Wax the vehicle when water will no longer bead on the paint.

Always wash and dry the vehicle before waxing. Use a good quality liquid or paste wax, and follow the manufacturer's instructions. Wax all metal trim to protect it and to maintain its luster.

Removing oil, tar, and similar materials with a spot remover will usually strip the wax from the finish. Be sure to re-wax these areas even if the rest of the vehicle does not yet need waxing.

### NOTICE

- **Wiping dust or dirt off the body with a dry cloth will scratch the finish.**
- **Do not use steel wool, abrasive cleaners, or strong detergents containing highly alkaline or caustic agents on chrome-plated or anodized aluminum parts. This may result in damage to the protective coating and cause discoloration or paint deterioration.**

### *Finish damage repair*

Deep scratches or stone chips in the painted surface must be repaired promptly. Exposed metal will quickly rust and may develop into a major repair expense.

### NOTICE

**If your vehicle is damaged and requires any metal repair or replacement, be sure the body shop applies anti-corrosion materials to the parts repaired or replaced.**

### ***Bright-metal maintenance***

- To remove road tar and insects, use a tar remover, not a scraper or other sharp object.
- To protect the surfaces of bright-metal parts from corrosion, apply a coating of wax or chrome preservative and rub to a high luster.
- During winter weather or in coastal areas, cover the bright metal parts with a heavier coating of wax or preservative. If necessary, coat the parts with non-corrosive petroleum jelly or other protective compound.

### ***Underbody maintenance***

Corrosive materials used for ice and snow removal and dust control may collect on the underbody. If these materials are not removed, accelerated rusting can occur on underbody parts such as the fuel lines, frame, floor pan and exhaust system, even though they have been treated with rust protection.

Thoroughly flush the vehicle underbody and wheel openings with lukewarm or cold water once a month, after off-road driving and at the end of each winter. Pay special attention to these areas because it is difficult to see all the mud and dirt. It will do more harm than good to wet down the road grime without removing it. The lower edges of doors, rocker panels, and frame members have drain holes that should not be allowed to clog with dirt; trapped water in these areas can cause rusting.

#### **⚠ WARNING**

**After washing the vehicle, test the brakes while driving slowly to see if they have been affected by water. If braking performance is impaired, dry the brakes by applying them lightly while maintaining a slow forward speed.**

### ***Aluminum wheel maintenance***

The aluminum wheels are coated with a clear protective finish.

#### **NOTICE**

- **Do not use any abrasive cleaner, polishing compound, solvent, or wire brushes on aluminum wheels.**
- **Clean the wheel when it has cooled.**
- **Use only a mild soap or neutral detergent, and rinse thoroughly with water. Also, be sure to clean the wheels after driving on salted roads.**
- **Do not wash the wheels with high-speed car wash brushes.**
- **Do not use any cleanser containing acid or alkaline detergents.**

### ***Corrosion protection***

#### **Protecting your vehicle from corrosion**

By using the most advanced design and construction practices to combat corrosion, we produce vehicles of the highest quality. However, this is only part of the job. To achieve the long-term corrosion resistance your vehicle can deliver, the owner's cooperation and assistance is also required.

#### **Common causes of corrosion**

The most common causes of corrosion on your vehicle are:

- Road salt, dirt and moisture that is allowed to accumulate underneath the vehicle.
- Removal of paint or protective coatings; by stones, gravel, abrasion or minor scrapes and dents which leave unprotected metal exposed to corrosion.

#### **High-corrosion areas**

If you live in an area where your vehicle is regularly exposed to corrosive materials, corrosion protection is particularly important. Some of the common causes of accelerated corrosion are road salts, dust control chemicals, ocean air and industrial pollution.

#### **Moisture breeds corrosion**

Moisture creates the conditions in which corrosion is most likely to occur. For example, corrosion is accelerated by high humidity, particularly when temperatures are just above freezing. In such conditions, the corrosive material is kept in contact with the vehicle surfaces by moisture that is slow to evaporate.

Mud is particularly corrosive because it is slow to dry and holds moisture in contact with the vehicle. Although the mud appears to be dry, it can still retain moisture and promote corrosion.

High temperatures can also accelerate corrosion of parts that are not properly ventilated so the moisture can be dispersed.

For all these reasons, it is particularly important to keep your vehicle clean and free of mud or accumulations of other materials. This applies not only to the visible surfaces but particularly to the underside of the vehicle.

#### **To help prevent corrosion**

You can help prevent corrosion from getting started by observing the following:

##### *Keep your vehicle clean*

The best way to prevent corrosion is to keep your vehicle clean and free of corrosive materials. Attention to the underside of the vehicle is particularly important.

- If you live in a high-corrosion area — where road salts are used, near the ocean, areas with industrial pollution, acid rain, etc.—, you should take extra care to prevent corrosion. In winter, hose off the underside of your car at least once a month and be sure to clean the underside thoroughly when winter is over.

- When cleaning underneath the vehicle, give particular attention to the components under the fenders and other areas that are hidden from view. Do a thorough job; just dampening the accumulated mud rather than washing it away will accelerate corrosion rather than prevent it. Water under high pressure and steam are particularly effective in removing accumulated mud and corrosive materials.
- When cleaning lower door panels, rocker panels and frame members, be sure that drain holes are kept open so that moisture can escape and not be trapped inside to accelerate corrosion.

### *Keep your garage dry*

Don't park your vehicle in a damp, poorly ventilated garage. This creates a favorable environment for corrosion. This is particularly true if you wash your vehicle in the garage or drive it into the garage when it is still wet or covered with snow, ice or mud. Even a heated garage can contribute to corrosion unless it is well ventilated so moisture is dispersed.

### *Keep paint and trim in good condition*

Scratches or chips in the finish should be covered with "touch-up" paint as soon as possible to reduce the possibility of corrosion. If bare metal is showing through, the attention of a qualified body and paint shop is recommended.

**Bird droppings :** Bird droppings are highly corrosive and may damage painted surfaces in just a few hours. Always remove bird droppings as soon as possible.

### *Don't neglect the interior*

Moisture can collect under the floor mats and vehicle petting to cause corrosion. Check under the mats periodically to be sure the carpeting is dry. Use particular care if you carry fertilizers, cleaning materials or chemicals in the vehicle.

These should be carried only in proper containers and any spills or leaks should be cleaned up, flushed with clean water and thoroughly dried.

## Interior care

### *Interior general precautions*

Prevent chemicals such as perfume, cosmetic oil, sun cream, hand cleaner and air freshener from contacting the interior parts because they may cause damage or discoloration. If they do contact the interior parts, wipe them off immediately.

See the instructions that follow for the proper way to clean vinyl.

#### **NOTICE**

**Never allow water or other liquids to come in contact with electrical/electronic components inside the vehicle as this may damage them.**

#### **NOTICE**

**When cleaning leather products (steering wheel, seats etc.), use neutral detergents or low alcohol content solutions. If you use high alcohol content solutions or acid/alkaline detergents, the color of the leather may fade or the surface may get stripped off.**

### ***Cleaning the upholstery and interior trim***

#### **Vinyl (if equipped)**

Remove dust and loose dirt from vinyl with a whisk broom or vacuum cleaner. Clean vinyl surfaces with a vinyl cleaner.

#### **Fabric (if equipped)**

Remove dust and loose dirt from fabric with a whisk broom or vacuum cleaner. Clean with a mild soap solution recommended for upholstery or carpets.

Remove fresh spots immediately with a fabric spot cleaner. If fresh spots do not receive immediate attention, the fabric can be stained and its color can be affected. Also, its fire-resistant properties can be reduced if the material is not properly maintained.

#### **NOTICE**

**Using anything but recommended cleaners and procedures may affect the fabric's appearance and fire-resistant properties.**

#### **Leather (if equipped)**

##### • Features of seat leather

- Leather is made from the outer skin of an animal, which goes through a special process to be available for use. Since it is a natural product, each part differs in thickness or density.

Wrinkles may appear as a natural result of stretching and shrinking depending on the temperature and humidity.

- The seat is made of stretchable fabric to improve comfort.
- The parts contacting the body are curved and the side supporting area is high which provides driving comfort and stability.
- Wrinkles may appear naturally from usage. It is not a fault of the products.



#### **CAUTION**

- **Wrinkles or abrasions which appear naturally from usage are not covered by warranty.**
- **Belts with metallic accessories, zippers or keys inside the back pocket may damage the seat fabric.**
- **Make sure not to wet the seat. It may change the nature of natural leather.**
- **Jeans or clothes which could bleach may contaminate the surface of the seat covering fabric.**

- Caring for the leather seats
  - Vacuum the seat periodically to remove dust and sand on the seat. It will prevent abrasion or damage of the leather and maintain its quality.
  - Wipe the natural leather seat cover often with dry or soft cloth.
  - Use of proper leather protector may prevent abrasion of the cover and helps maintain the color. Be sure to read the instructions and consult a specialist when using leather coating or protective agent.
  - Light colored (beige, cream beige) leather is easily contaminated and the stain is noticeable. Clean the seats frequently.
  - Avoid wiping with wet cloth. It may cause the surface to crack.
- Cleaning the leather seats
  - Remove all contaminations instantly. Refer to instructions below for removal of each contaminant.
  - Cosmetic products (sunscreen, foundation, etc.)

Apply cleansing cream on a cloth and wipe the contaminated spot. Wipe off the cream with a wet cloth and remove water with a dry cloth.
  - Beverages (coffee, soft drink, etc.)

Apply a small amount of neutral detergent and wipe until contaminations do not smear.
  - Oil

Remove oil instantly with absorbable cloth and wipe with stain remover used only for natural leather.
  - Chewing gum

Harden the gum with ice and remove gradually.

### ***Cleaning the lap/shoulder belt webbing***

Clean the belt webbing with any mild soap solution recommended for cleaning upholstery or carpet. Follow the instructions provided with the soap. Do not bleach or re-dye the webbing because this may weaken it.

### ***Cleaning the interior window glass***

If the interior glass surfaces of the vehicle become fogged (that is, covered with an oily, greasy or waxy film), they should be cleaned with glass cleaner. Follow the directions on the glass cleaner container.

#### **NOTICE**

**Do not scrape or scratch the inside of the rear window. This may result in damage to the rear window defroster grid.**

### EMISSION CONTROL SYSTEM

The emission control system of your vehicle is covered by a written limited warranty. Please see the warranty information contained in the Service Passport in your vehicle.

Your vehicle is equipped with an emission control system to meet all emission regulations.

There are three emission control systems which are as follows.

- (1) Crankcase emission control system
- (2) Evaporative emission control system
- (3) Exhaust emission control system

In order to ensure the proper function of the emission control systems, it is recommended that you have your car inspected and maintained by an authorized HYUNDAI dealer in accordance with the maintenance schedule in this manual.

#### CAUTION

##### **For the Inspection and Maintenance Test (with Electronic Stability Control (ESC) system)**

- **To prevent the vehicle from misfiring during dynamometer testing, turn the Electronic Stability Control (ESC) system off by pressing the ESC switch.**
- **After dynamometer testing is completed, turn the ESC system back on by pressing the ESC switch again.**

#### 1. Crankcase emission control system

The positive crankcase ventilation system is employed to prevent air pollution caused by blow-by gases being emitted from the crankcase. This system supplies fresh filtered air to the crankcase through the air intake hose. Inside the crankcase, the fresh air mixes with blow-by gases, which then pass through the PCV valve into the induction system.

#### 2. Evaporative emission control system

The Evaporative Emission Control System is designed to prevent fuel vapors from escaping into the atmosphere.

##### ***Canister***

Fuel vapors generated inside the fuel tank are absorbed and stored in the onboard canister. When the engine is running, the fuel vapors absorbed in the canister are drawn into the surge tank through the purge control solenoid valve.

##### ***Purge Control Solenoid Valve (PCSV)***

The purge control solenoid valve is controlled by the Engine Control Module (ECM); when the engine coolant temperature is low during idling, the PCSV closes so that evaporated fuel is not taken into the engine. After the engine warms-up during ordinary driving, the PCSV opens to introduce evaporated fuel to the engine.



### 3. Exhaust emission control system

The Exhaust Emission Control System is a highly effective system which controls exhaust emissions while maintaining good vehicle performance.

#### **Vehicle modifications**

This vehicle should not be modified. Modification of your vehicle could affect its performance, safety or durability and may even violate governmental safety and emissions regulations.

In addition, damage or performance problems resulting from any modification may not be covered under warranty.

- If you use unauthorized electronic devices, it may cause the vehicle to operate abnormally, wire damage, battery discharge and fire. For your safety, do not use unauthorized electronic devices.

#### **Engine exhaust gas precautions (carbon monoxide)**

- Carbon monoxide can be present with other exhaust fumes. Therefore, if you smell exhaust fumes of any kind inside your vehicle, have it inspected and repaired immediately. If you ever suspect exhaust fumes are coming into your vehicle, drive it only with all the windows fully open. Have your vehicle checked and repaired immediately.

#### **⚠ WARNING**

**Engine exhaust gases contain carbon monoxide (CO). Though colorless and odorless, it is dangerous and could be lethal if inhaled. Follow the instructions following to avoid CO poisoning.**

- Do not operate the engine in confined or closed areas (such as garages) any more than what is necessary to move the vehicle in or out of the area.
- When the vehicle is stopped in an open area for more than a short time with the engine running, adjust the ventilation system (as needed) to draw outside air into the vehicle.
- Never sit in a parked or stopped vehicle for any extended time with the engine running.
- When the engine stalls or fails to start, excessive attempts to restart the engine may cause damage to the emission control system.

### ***Operating precautions for catalytic converters (if equipped)***

#### **WARNING**

- **A hot exhaust system can ignite flammable items under your vehicle. Do not park, idle, or drive the vehicle over or near flammable objects, such as dry grass, paper, leaves, etc.**
- **The exhaust system and catalytic system are very hot while the engine is running or immediately after the engine is turned off. Keep away from the exhaust system and catalytic converter as you may get burned.**

**Also, do not remove the heat sink around the exhaust system, do not seal the bottom of the vehicle and do not coat the vehicle for corrosion control. It may present a fire risk under certain conditions.**

Your vehicle is equipped with a catalytic converter emission control device.

Therefore, the following precautions must be observed:

- Use only UNLEADED FUEL for gasoline engines.
  - Do not operate the vehicle when there are signs of engine malfunction, such as misfire or a noticeable loss of performance.
  - Do not misuse or abuse the engine. Examples of misuse are coasting with the engine off and descending steep grades in gear with the engine off.
  - Do not operate the engine at high idle speed for extended periods (5 minutes or more).
- Do not modify or tamper with any part of the engine or emission control system. All inspections and adjustments must be made by an authorized HYUNDAI dealer.
  - Avoid driving with a very low fuel level. If you run out of gasoline, it could cause the engine to misfire and result in excessive loading of the catalytic converter.

Failure to observe these precautions could result in damage to the catalytic converter and to your vehicle.

Additionally, such actions could void your warranties.

## Specifications & Consumer information

Dimensions .....	8-2
Engine .....	8-2
Bulb wattage .....	8-3
Tires and wheels .....	8-4
Tire load and speed capacity .....	8-5
Air conditioning system .....	8-5
Vehicle weight and luggage volume .....	8-5
Recommended lubricants and capacities .....	8-6
Recommended SAE viscosity number .....	8-7
Vehicle identification number (VIN) .....	8-8
Vehicle certification label .....	8-8
Tire specification and pressure label .....	8-9
Engine number .....	8-9
Air conditioner compressor label .....	8-9
Refrigerant label .....	8-10
Declaration of conformity .....	8-10

## DIMENSIONS

Items		mm (in)
Overall length		4335 (170.67)
Overall width	without outside mirrors	1795 (70.66)
	with outside mirrors	2039 (80.27)
Overall height		1451 (57.13) <sup>*1</sup> / 1447 (56.97) <sup>*2</sup>
Front wheel tread	225/40 ZR18	1557 (61.30)
	235/35R19	1556 (61.26)
Rear wheel tread	225/40 ZR18	1566 (61.65)
	235/35R19	1564 (61.57)
Wheelbase		2650 (104.33)

\*1 : 18 inch tire

\*2 : 19 inch tire

## ENGINE

Displacement	Bore x Stroke	Firing Order	No. of Cylinders
1998 cc (121.9 cu. in)	86.0 X 86.0 mm (3.39 x 3.39 in.)	1-3-4-2	4. In-line

## BULB WATTAGE

Light Bulb		Bulb Type	Wattage
Front	Headlamp	Low	LED
		High	LED
	Position lamp	LED	LED
	Turn signal lamp	LED	LED
	Static bending light (SBL)	LED	LED
	Daytime running light	LED	LED
	Side repeater lamp	LED	LED
Rear	Stop/Tail lamp	LED	LED
	Turn signal lamp	PY21W	21
	Backup lamp	W16W	16
	Rear fog lamp	PY21W	21
	High mounted stop light	LED	LED
	License plate lamp	FESTOON	5
Interior	Map lamp	W10W	10
	Room lamp	Type A	FESTOON
		Type B	LED
	Vanity mirror lamp	FESTOON	5
	Glove box lamp	FESTOON	5
	Luggage compartment lamp	FESTOON	10

## TIRES AND WHEELS

Item	Tire Size	Wheel Size	Inflation Pressure kPa (bar, psi)				Wheel Lug Nut Torque kgf·m (lbf·ft, N·m)
			Normal Load		Maximum Load		
			Front	Rear	Front	Rear	
Full size tire	225/40 ZR18	7.5J X 18	250 (2.5, 36)	230 (2.3, 33)	250 (2.5, 36)	230 (2.3, 33)	11~13 (79~94, 107~127)
	235/35 R19	8.0J X 19	260 (2.6, 38)	240 (2.4, 35)	290 (2.9, 42)	270 (2.7, 39)	
Compact spare tire	T125/70 R18	4.0T X 18	420 (4.2, 60)				

If your vehicle is not equipped with a compact spare tire, your vehicle will be equipped with a Tire Mobility Kit.

### NOTICE

- It is permissible to add 20 kPa (3 psi) to the standard tire pressure specification if colder temperatures are expected soon. Tires typically lose 7 kPa (1 psi) for every 7°C (12°F) temperature drop. If extreme temperature variations are expected, recheck your tire pressure as necessary to keep them properly inflated.
- An air pressure generally decreases, as you drive up to a high-altitude area above sea level. Thus, if you plan to drive a high-altitude area, check the tire pressures in advance. If necessary, inflate them to a proper level (Air inflation per altitude: +10 kPa/1 km (+2.4 psi/1 mile)).

### CAUTION

When replacing tires, use the same size originally supplied with the vehicle.  
Using tires of a different size can damage the related parts or make it work irregularly.

## TIRE LOAD AND SPEED CAPACITY (FOR EUROPE)

Item	Tire Size	Wheel Size	Load Capacity		Speed Capacity	
			LI *1	kg	SS *2	km/h
Full size tire	225/40 ZR18	7.5J X 18	92	630	Y	300
	235/35 R19	8.0J X 19	91	615	Y	300

\*1 LI : LOAD INDEX

\*2 SS : SPEED SYMBOL

## AIR CONDITIONING SYSTEM

Items	Weight of Volume	Classification
Refrigerant g (oz.)	475 ~525 (16.76 ~ 18.52)	R-1234yf (For Europe) R-134a (Except Europe)
Compressor lubricant g (oz.)	100 ~ 120 (3.52 ~ 4.23)	PAG

Contact an authorized HYUNDAI dealer for more details.

## VEHICLE WEIGHT AND LUGGAGE VOLUME

Gross Vehicle Weight kg (lbs.)	Luggage Volume / (cu ft.)	
	Min.	Max.
1950 (4299)	395 (13.95) / 381 (13.45)*1	1301 (45.94) / 1287 (45.45)*1

\*1 : vehicles with rear stiffness-bar

Min : Behind rear seat to upper edge of the seat back.

Max : Behind front seat to roof.

## RECOMMENDED LUBRICANTS AND CAPACITIES

To help achieve proper engine and powertrain performance and durability, use only lubricants of the proper quality. The correct lubricants also help promote engine efficiency that results in improved fuel economy.

These lubricants and fluids are recommended for use in your vehicle.

Lubricant	Volume	Classification
Engine oil <sup>*1</sup> <sup>*2</sup> (drain and refill) Recommends 	4.8 l (5.07 US qt.)	ACEA C2 or above / 0W-30
Manual transmission fluid	1.8 ~ 1.9 l (1.9 ~ 2.0 US qt.)	HK SYN MTF 70W (SK) SPIRAX S6 GHME 70W MTF (H.K.SHELL) GS MTF HD 70W (GS CALTEX) (API GL-4, SAE 70W)
Coolant	8.5 l (9.0 US qt.)	Mixture of antifreeze and distilled water (Ethylene-glycol with phosphate based coolant for aluminum radiator)
Brake/clutch fluid	0.7 ~ 0.8 l (0.7 ~ 0.8 US qt.)	FMVSS116 DOT-3 or DOT-4
Fuel	50 l (13.21 US gal.)	Refer to "Fuel Requirements" in the Introduction chapter.

\*1 : Refer to the recommended SAE viscosity numbers on page 7.

\*2 : Engine oils labeled Energy Conserving Oil are now available. Along with other additional benefits, they contribute to fuel economy by reducing the amount of fuel necessary to overcome engine friction. Often, these improvements are difficult to measure in everyday driving, but in a year's time, they can offer significant cost and energy savings.



## Recommended SAE viscosity number

### CAUTION

Always be sure to clean the area around any filler plug, drain plug, or dipstick before checking or draining any lubricant. This is especially important in dusty or sandy areas and when the vehicle is used on unpaved roads. Cleaning the plug and dipstick areas will prevent dirt and grit from entering the engine and other mechanisms that could be damaged.

Engine oil viscosity (thickness) has an effect on fuel economy and cold weather operating (engine start and engine oil flowability). Lower viscosity engine oils can provide better fuel economy and cold weather performance, however, higher viscosity engine oils are required for satisfactory lubrication in hot weather. Using oils of any viscosity other than those recommended could result in engine damage.

When choosing an oil, consider the range of temperature your vehicle will be operated in before the next oil change. Proceed to select the recommended oil viscosity from the chart.

		Temperature Range for SAE Viscosity Numbers									
Temperature	°C	-30	-20	-10	0	10	20	30	40	50	
	(°F)	-10	0	20	40	60	80	100	120		
For all countries *1							20W-50				
							15W-40				
							10W-30				
						0/5W-30, 5W-40					

\*1 : For better fuel economy, it is recommended to use the engine oil of a viscosity grade SAE 0W-30. However, if the engine oil is not available in your country, select the proper engine oil using the engine oil viscosity chart.

## VEHICLE IDENTIFICATION NUMBER (VIN)

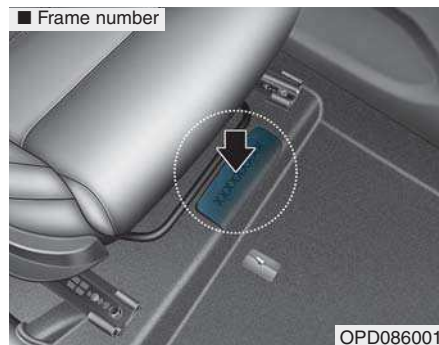

The vehicle identification number (VIN) is the number used in registering your vehicle and in all legal matters pertaining to its ownership, etc. The number is punched on the floor under the passenger seat. To check the number, open the cover.

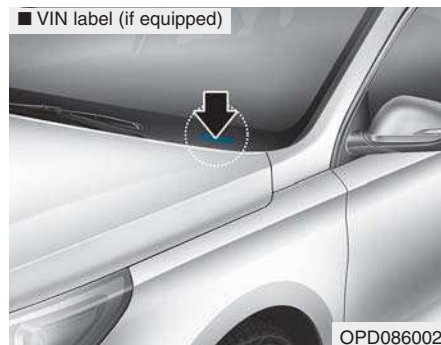

The VIN is also on a plate attached to the top of the dashboard. The number on the plate can easily be seen through the windshield from outside.

## VEHICLE CERTIFICATION LABEL



The vehicle certification label attached on the driver's (or front passenger's) side center pillar gives the vehicle identification number (VIN).

## TIRE SPECIFICATION AND PRESSURE LABEL



OPD086007

The tires supplied on your new vehicle are chosen to provide the best performance for normal driving.

The tire label located on the driver's side center pillar gives the tire pressures recommended for your vehicle.

## ENGINE NUMBER

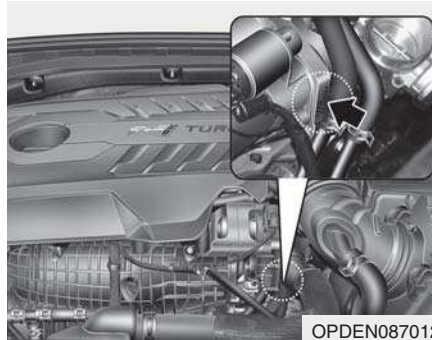

OPDEN087012

The engine number is stamped on the engine block as shown in the drawing.

## AIR CONDITIONER COMPRESSOR LABEL



OHC081001

A compressor label informs you the type of compressor your vehicle is equipped with such as model, supplier part number, production number, refrigerant (1) and refrigerant oil (2).

## REFRIGERANT LABEL



The refrigerant label provides information such as refrigerant type and amount.

The label is located on the underside of the hood.

## DECLARATION OF CONFORMITY (IF EQUIPPED)

■ Example

CE CE 0678

CE0678

The radio frequency components of the vehicle comply with requirements and other relevant provisions of Directive 1995/5/EC.

Further information including the manufacturer's declaration of conformity is available on HYUNDAI web site as follows;

<http://service.hyundai-motor.com>

# Index

**A**

- Air bag warning labels ..... 2-63
- Air bags..... 2-45
  - Additional safety precautions ..... 2-63
  - Air bag collision sensors ..... 2-57
  - Air bag inflation conditions ..... 2-59
  - Air bag non-inflation conditions ..... 2-60
  - Air bag warning labels..... 2-63
  - Curtain air bags..... 2-51
  - Do not install a child restraint on
    - the front passenger seat ..... 2-57
  - Driver's air bag..... 2-47
  - Driver's knee air bag..... 2-47
  - How does the air bags system operate?..... 2-52
  - Passenger's front air bag ON/OFF switch ..... 2-48
  - Passenger's front air bag ..... 2-47
  - Side air bags..... 2-50
  - SRS Care..... 2-62
  - SRS components and functions ..... 2-52
  - SRS warning light..... 2-53
  - What to expect after an air bag inflates..... 2-56
  - Why didn't my air bag go off in a collision ..... 2-57
- Air conditioner compressor label ..... 8-9
- Air conditioning refrigerant label ..... 3-114
- Air conditioning system specification ..... 8-5
- Air filter ..... 7-27
- Alarm system ..... 3-16
- Antenna ..... 4-2
- Anti-lock brake system (ABS) ..... 5-26
- Appearance care ..... 7-71
  - Exterior care..... 7-71
  - Interior care..... 7-75
- Armrest ..... 2-15
- Ashtray..... 3-121
- Audio / Video / Navigation system ..... 4-4
- Auto defogging system ..... 3-117
- Auto light position ..... 3-79
- Automatic climate control system ..... 3-103
  - Air conditioning..... 3-110
  - Air conditioning refrigerant label ..... 3-114
  - Air intake control..... 3-108
  - Automatic heating and air conditioning ..... 3-104
  - Fan speed control..... 3-109
  - Manual heating and air conditioning ..... 3-105
  - Mode selection..... 3-106
  - OFF mode ..... 3-110
  - SYNC button ..... 3-108
  - System maintenance..... 3-113
  - Temperature control ..... 3-107
- Automatic ventilation ..... 3-118
- Autonomous Emergency Braking (AEB) system
  - Camera type ..... 5-49
- Aux, USB and iPod ..... 4-2

## B

Battery.....	7-33
Battery recharging.....	7-35
Battery saver function.....	3-85
Before driving.....	5-4
Blade type fuse.....	7-49
Bluetooth® Wireless Technology hands-free.....	4-4
Bottle holder.....	3-121
Brake system.....	5-23
Anti-lock brake system (ABS).....	5-26
Disc brakes wear indicator.....	5-24
Electronic Stability Control (ESC).....	5-28
Emergency Stop Signal (ESS).....	5-35
Good braking practices.....	5-36
High performance brake.....	5-24
Hill-start Assist Control (HAC).....	5-35
Parking brake.....	5-25
Power brakes.....	5-23
Vehicle Stability Management (VSM).....	5-33
Brake/clutch fluid.....	7-25
Bulb replacement.....	7-61
Daytime running light (DRL).....	7-62
Front position lamp.....	7-62
Front turn signal lamp.....	7-62
Headlamp.....	7-62
Headlamp aiming.....	7-62
High mounted stop lamp.....	7-69

Interior light bulb.....	7-69
License plate light bulb.....	7-69
Rear combination light bulb.....	7-66
Rear fog lamp.....	7-68
Side repeater lamp.....	7-66
Static bending lamp.....	7-62
Bulb wattage.....	8-3
Button start/stop, see engine start/stop button.....	5-9

## C

Camera (Rear view).....	3-95
Capacities (Lubricants).....	3-6
Care.....	
Exterior care.....	7-71
Interior care.....	7-75
Tire care.....	7-38
Cargo area cover.....	3-129
Cartridge type fuse.....	7-49
Cellular phone holder.....	3-125
Center console storage.....	3-119
Central door lock switch.....	3-13
Certification label.....	8-8
Chains.....	
Tire chains.....	5-95
Check tire inflation pressure.....	7-39
Child restraint system (CRS).....	2-34
Booster seats.....	2-37
Forward-facing child restraint system.....	2-36

Installing a child restraint system (CRS).....	2-37
ISOFIX anchorage and top-tether anchorage for children .....	2-38
Rearward-facing child restraint system .....	2-36
Securing a child restraint system seat with "Top-tether Anchorage" system.....	3-40
Securing a child restraint system with a lap/shoulder belt.....	3-42
Securing a child restraint system with the "ISOFIX Anchorage System".....	2-39
Selecting a child restraint system (CRS).....	2-35
Child-protector rear door lock.....	3-15
Cigarette lighter .....	3-124
Climate control air filter.....	7-29
Climate control system	
Automatic climate control system.....	3-103
Clock.....	3-126
Clothes hanger.....	3-127
Cluster ionizer.....	3-118
Combined instrument, see instrument cluster .....	3-43
Compact spare tire replacement .....	7-42
Coolant.....	7-22
Cooling fluid, see engine coolant.....	7-22
Crankcase emission control system.....	7-78
Cruise control system .....	5-85
Cup holder .....	3-121
Curtain air bags.....	2-51
CUSTOM mode.....	5-42

**D**

Dashboard illumination, see instrument panel illumination.....	3-44
Dashboard, see instrument cluster.....	3-43
Day/night rearview mirror.....	3-22
Daytime running light (DRL).....	3-86
Declaration of conformity .....	8-10
Defogging (Windshield) .....	3-115
Defroster .....	3-116
Rear window defroster.....	3-117
Defrosting (Windshield) .....	3-115
Dimensions .....	8-2
Display illumination, see instrument panel illumination.....	3-44
Displays, see instrument cluster.....	3-43
Distance to empty .....	3-47
Door locks.....	3-11
Auto door lock/unlock features .....	3-14
Central door lock switch.....	3-13
Child-protector rear door lock.....	3-15
Drinks holders, see cup holders.....	3-121
DRIVE MODE button.....	5-40
Drive mode integrated control system .....	5-40
CUSTOM mode.....	5-42
DRIVE MODE button.....	5-40
ECO mode .....	5-40
N button .....	5-41
N mode.....	5-42
SPORT mode .....	5-41
Vehicle characteristic .....	5-43



Driver Attention Alert (DAA) system .....	5-78
Driver position memory system .....	3-17
Easy access function .....	3-18
Recalling memory positions .....	3-17
Storing memory positions.....	3-17
Driver's air bag .....	2-47
Driver's knee air bag.....	2-47
Driving at night.....	5-92
Driving in flooded areas .....	5-93
Driving in the rain .....	5-92

## E

Easy access function.....	3-18
ECO mode .....	5-40
Electric chromic mirror (ECM).....	3-23
Electric power steering (EPS) .....	3-19
Electronic Control Suspension (ECS) .....	5-37
Electronic limited slip differential.....	5-38
Drive mode selection.....	5-38
Electronic stability control (ESC) .....	5-28
ESC SPORT .....	5-30
Drive mode selection.....	5-32
Emergency Stop Signal (ESS).....	5-35
Emergency towing.....	6-39
Emission control system.....	7-78
Crankcase emission control system.....	7-78
Evaporative emission control System .....	7-78
Exhaust emission control system.....	7-79

Engine compartment.....	1-7
Engine compartment.....	7-3
Engine compartment panel fuse replacement.....	7-49
Engine coolant .....	7-22
Engine coolant temperature gauge .....	3-45
Engine number.....	8-9
Engine oil.....	7-20
Engine specification .....	8-2
Engine start/stop button.....	5-9
Evaporative emission control System .....	7-78
Exhaust emission control system .....	7-79
Explanation of scheduled maintenance items .....	7-18
Exterior care .....	7-71
Exterior overview	
Front view .....	1-2
Rear view .....	1-3

## F

Flat tire	
Changing tires.....	6-15
Tire Mobility Kit (TMK).....	6-23
Floor mat anchor(s) .....	3-127
Fluid	
Brake/clutch fluid .....	7-25
Washer fluid.....	7-26
Front seat adjustment.....	2-6
Manual adjustment.....	2-7
Power adjustment.....	2-9
Seatback pocket .....	2-12

Front seat headrests	
Adjusting the height up and down.....	2-17
Forward and rearward adjustment.....	2-17
Removal/Reinstall.....	2-18
Fuel filler door.....	3-40
Fuel gauge.....	3-46
Fuel requirements.....	F-6
Do not use methanol.....	F-8
Fuel Additives.....	F-8
Gasoline containing alcohol and methanol.....	F-7
Leaded.....	F-7
Operation in foreign countries.....	F-8
Other fuels.....	F-7
Unleaded.....	F-6
Use of MTBE.....	F-8
Fuses.....	7-47
Blade type fuse.....	7-49
Cartridge type fuse.....	7-49
Engine compartment panel fuse replacement.....	7-49
Fuse switch.....	7-49
Fuse/relay panel description.....	7-51
Instrument panel fuse replacement.....	7-48
Main fuse.....	7-50
Multi fuse.....	7-50

## G

Gauges and meters.....	3-44
Glove box.....	3-119

## H

Hazard warning flasher.....	6-2
Hazardous driving conditions.....	5-91
Headlamp delay function.....	3-85
Headlamp leveling device.....	3-86
Headlamp position.....	3-80
Headlight bulb replacement.....	7-61
Headrest.....	2-16
Front seat headrests.....	2-17
Rear seat headrests.....	2-19
Heated steering wheel.....	3-21
Height adjustment.....	2-27
High beam operation.....	3-80
High performance brake.....	5-24
Highway driving.....	5-93
Hill-start Assist Control (HAC).....	5-35
Hood.....	3-37
Horn.....	3-21
How to use this manual.....	F-5

## I

If the engine doesn't turn over or turns over slowly.....	6-3
If the engine overheats.....	6-7
If the engine stalls at a crossroad or crossing.....	6-2
If the engine stalls while driving.....	6-2
If the engine turns over normally but doesn't start.....	6-4
If the engine will not start.....	6-3

If you have a flat tire while driving .....	6-3
Ignition switch .....	5-6
Engine Start/Stop button .....	5-9
Key ignition switch .....	5-6
Immobilizer system .....	3-10
Impact sensing door unlock .....	3-14
Important safety precautions .....	2-2
Air bag hazards .....	2-2
Always wear your seat belt .....	2-2
Control your speed .....	2-3
Driver distraction .....	2-2
Keep your vehicle in safe condition .....	2-3
Restrain all children .....	2-2
In case of emergency while driving .....	6-2
Indicator light .....	3-49
Inside rearview mirror .....	3-22
Instrument cluster .....	3-43
Assist mode .....	3-70
Gauges and meters .....	3-44
Instrument panel illumination .....	3-44
LCD display control .....	3-67
LCD display messages .....	3-61
LCD display modes .....	3-68
Manual transmission shift indicator .....	3-48
Shift lights .....	3-48
Trip computer mode .....	3-69
User settings mode .....	3-72
Warning and indicator lights .....	3-49

Instrument panel fuse replacement .....	7-48
Instrument panel overview .....	1-5
Interior care .....	7-75
Interior features	
Ashtray .....	3-121
Bottle holder .....	3-121
Cargo area cover .....	3-129
Cellular phone holder .....	3-125
Cigarette lighter .....	3-124
Clock .....	3-126
Clothes hanger .....	3-127
Cup holder .....	3-121
Floor mat anchor(s) .....	3-127
Luggage net (holder) .....	3-128
Power outlet .....	3-123
Sunvisor .....	3-122
Wireless cellular phone charging system .....	3-125
Interior lamp AUTO cut .....	3-88
Interior lights .....	3-88
Front lamps .....	3-88
Interior lamp AUTO cut .....	3-88
Luggage compartment lamp .....	3-89
Puddle lamp .....	3-90
Rear lamps .....	3-89
Vanity mirror lamp .....	3-90
Interior overview .....	1-4
ISG (Idle Stop and Go) system .....	5-44

**J**

Jump starting.....6-4

**L**

## Label

Air conditioner compressor label .....8-9  
 Refrigerant label .....8-10  
 Tire sidewall labeling.....7-42  
 Tire specification and pressure label .....8-9  
 Vehicle certification label .....8-8

Lane change signals.....3-84

Lane Departure Warning System (LDWS).....5-73

Lane Keeping Assist System (LKAS) .....5-64

Lap/shoulder belt .....2-25

Launch control.....5-21

## LCD display

LCD display control .....3-67

LCD display modes .....3-68

## LCD display messages

Beware of engine damage when shifting while in  
 high RPM.....3-66

Check AEB system .....3-65

Check driver attention alert .....3-65

Check ECS.....3-66

Check headlamp FAN.....3-65

Check headlamp LED.....3-65

Check headlight .....3-64

Check LDWS.....3-65

Check limited slip differential .....3-66

Check LKAS.....3-65

Check smart high beam system .....3-65

Check steering wheel lock system.....3-61

Door, Hood, Tailgate open.....3-62

Engine has overheated.....3-64

Heated Steering Wheel turned off .....3-64

Key not detected .....3-62

Key not in vehicle.....3-61

Lights mode .....3-63

Low fuel.....3-64

Low Key Battery .....3-61

Low pressure.....3-63

Low washer fluid .....3-64

Press clutch pedal to start engine .....3-61

Press START button again.....3-62

Press START button while turning wheel .....3-61

Press START button with key .....3-62

Steering wheel unlocked.....3-61

Sunroof open.....3-62

Turn on FUSE SWITCH .....3-64

Tyre size mismatch.Check tyre sizes.....3-66

Wiper mode.....3-63

LCD display modes .....3-68

Assist mode.....3-70

Gauges (Engine) .....3-70

G-Force .....3-71

Lap timer.....3-70

Quick guide help.....	3-69
Trip computer mode.....	3-69
Turn By Turn (TBT) mode.....	3-70
User settings mode.....	3-72
Warning message mode.....	3-72
Light bulbs.....	7-61
Lighting.....	3-79
Auto light position.....	3-79
Battery saver function.....	3-85
Daytime running light (DRL).....	3-86
Headlamp delay function.....	3-85
Headlamp leveling device.....	3-86
Headlamp position.....	3-80
High beam operation.....	3-80
Lane change signals.....	3-84
Position lamp position.....	3-80
Rear fog lamp.....	3-84
Smart high beam.....	3-81
Static bending light.....	3-86
Turn signals.....	3-84
Lubricants and capacities.....	8-6
Luggage compartment lamp.....	3-89
Luggage net (holder).....	3-128

## M

Main fuse.....	7-50
Maintenance	
Explanation of scheduled maintenance items.....	7-18

Maintenance services.....	7-4
Maintenance under severe usage conditions.....	7-11, 16
Normal maintenance schedule.....	7-8, 13
Owner maintenance.....	7-5
Scheduled maintenance services.....	7-7
Tire maintenance.....	7-42
Maintenance services.....	7-4
Maintenance under severe usage conditions	
Except Europe.....	7-16
For Europe.....	7-11
Manual transmission.....	5-14
Downshifting.....	5-15
Good driving practices.....	5-16
Rev matching.....	5-17
Using the clutch.....	5-15
Manual transmission shift indicator.....	3-48
Mirrors.....	3-22
Adjusting the outside rearview mirrors.....	3-24
Day/night rearview mirror.....	3-22
Electric chromic mirror (ECM).....	3-23
Folding/Unfolding the outside rearview mirror.....	3-25
Inside rearview mirror.....	3-22
Outside rearview mirror.....	3-23
Reverse parking aid function.....	3-26
Moonroof, see sunroof.....	3-32
Multi fuse.....	7-50
Multimedia system.....	4-2
Antenna.....	4-2
Audio / Video / Navigation system.....	4-4

## Index

- Aux, USB and iPod .....4-2
- Bluetooth® Wireless Technology hands-free .....4-4
- Steering wheel audio control .....4-3

## N

- N button .....5-41
- N mode .....5-42
- Normal maintenance schedule
  - Except Europe .....7-13
  - For Europe .....7-8

## O

- Odometer .....3-47
- Oil (Engine) .....7-20
- Outside rearview mirror .....3-23
- Outside temperature gauge .....3-47
- Owner maintenance .....7-5

## P

- Panorama sunroof, see sunroof .....3-32
- Parking assist system .....3-100
- Parking brake .....5-25
- Passenger's front air bag ON/OFF switch .....2-48
- Passenger's front air bag .....2-47
- Position lamp position .....3-80
- Power brakes .....5-23
- Power outlet .....3-123

- Power steering .....3-19
- Power window lock switch .....3-30
- Pre-tensioner seat belt .....2-28
- Puddle lamp .....3-90

## R

- Rear center seat belt .....2-27
- Rear fog lamp .....3-84
- Rear parking assist system .....3-96
- Rear seat adjustment .....2-12
  - Armrest .....2-15
  - Carrying long/narrow cargo .....2-15
  - Folding the rear seat .....2-12
- Rear seat headrests .....2-19
  - Adjusting the height up and down .....2-20
- Rear view camera .....3-95
- Rear window wiper and washer switch .....3-94
- Recommended cold tire inflation pressures .....7-38
- Recommended lubricants and capacities .....8-6
- Refrigerant label .....8-10
- Remote key .....3-3
  - Battery replacement .....3-5
  - Locking .....3-3
  - Mechanical key .....3-4
  - Tailgate unlocking .....3-3
  - Unlocking .....3-3
- Removable towing hook .....6-38
- Replacement light bulb .....7-61

Returning used vehicles .....	F-9
Rev matching.....	5-17
Reverse parking aid function.....	3-26
Rocking the vehicle .....	5-91
Rotation (Tire) .....	7-39

## S

Safety messages.....	F-5
Scheduled maintenance services .....	7-7
Seat belt warning light	
Driver's seat .....	2-23
Front passenger's seat .....	2-24
Rear passenger's seat .....	2-25
Seat belts.....	2-22
Additional seat belt safety precautions.....	2-31
Care of seat belts .....	2-33
Do not lie down .....	2-33
Height adjustment.....	2-27
Keep belts clean and dry.....	2-33
Lap/shoulder belt .....	2-25
One person per belt.....	2-33
Periodic inspection.....	2-33
Pre-tensioner seat belt.....	2-28
Rear center seat belt.....	2-27
Seat belt restraint system .....	2-25
Seat belt safety precautions .....	2-22
Seat belt use and children.....	2-31
Seat belt use and injured people.....	2-33
Seat belt use during pregnancy.....	2-31
Seat belt warning light.....	2-23
When to replace seat belts .....	2-34
Seat warmers .....	2-20
Seats.....	2-4
Front seat adjustment.....	2-6
Front seat warmers.....	2-20
Headrest .....	2-16
Rear seat adjustment.....	2-12
Safety precautions.....	2-5
Shift lights.....	3-48
Side air bags .....	2-50
Smart high beam.....	3-81
Smart key.....	3-6
Battery replacement.....	3-9
Locking .....	3-6
Mechanical key.....	3-8
Tailgate unlocking.....	3-7
Unlocking.....	3-7
Smooth cornering .....	5-92
Snow tires .....	5-94
Spare tire	
Compact spare tire replacement .....	7-42
Special driving conditions	
Driving at night.....	5-92
Driving in flooded areas .....	5-93
Driving in the rain .....	5-92
Hazardous driving conditions .....	5-91
Highway driving .....	5-93

Rocking the vehicle .....5-91

Smooth cornering.....5-92

Speed limit control system .....5-82

Speed Limit Information Function (SLIF) .....5-60

Speed sensing door lock .....3-14

Speedometer .....3-44

SPORT mode .....5-41

Starting difficulties, see engine will not start.....6-3

Static bending light.....3-86

Steering wheel

    Electric Power Steering (EPS).....3-19

    Heated steering wheel.....3-21

    Horn .....3-21

    Power steering .....3-19

    Tilt steering / Telescope steering .....3-20

Steering wheel audio control.....4-3

Storage compartment.....3-119

    Center console storage.....3-119

    Glove box.....3-119

    Sunglass holder.....3-120

Sunglass holder.....3-120

Sunroof .....3-32

    Automatic reverse.....3-34

    Closing the sunroof.....3-34

    Resetting the sunroof.....3-35

    Sliding the sunroof.....3-33

    Sunroof open warning .....3-36

    Sunshade .....3-33

    Tilting the sunroof .....3-34

Sunroof inside air recirculation .....3-118

Sunvisor .....3-122

**T**

Tachometer

    Variable LED tachometer .....3-45

Tailgate .....3-38

Theft-alarm system.....3-16

Tilt steering / Telescope steering.....3-20

Tire chains .....5-95

Tire load and speed capacity .....8-5

Tire Mobility Kit (TMK).....6-23

Tire pressure monitoring system (TPMS).....6-8

Tire rotation .....7-39

Tire specification and pressure label .....8-9

Tires and wheels .....7-37

    Check tire inflation pressure.....7-39

    Compact spare tire replacement .....7-42

    Low aspect ratio tires.....7-46

    Recommended cold tire inflation pressures .....7-38

    Tire care .....7-38

    Tire maintenance.....7-42

    Tire replacement .....7-41

    Tire rotation .....7-39

    Tire sidewall labeling.....7-42

    Tire traction.....7-42

    Wheel alignment and tire balance .....7-40

    Wheel replacement .....7-42



Tires and wheels specification.....	8-4
Towing .....	6-37
Trailer towing .....	5-99
Trip computer .....	3-76
Accumulated Info display.....	3-77
Average fuel economy .....	3-77
Digital speedometer .....	3-78
Instant fuel economy .....	3-77
Turn signals .....	3-84

## U

User settings mode .....	3-72
--------------------------	------

## V

Vanity mirror lamp .....	3-90
Vehicle break-in process.....	F-9
Vehicle certification label .....	8-8
Vehicle identification number (VIN).....	8-8
Vehicle modification.....	F-9
Vehicle Stability Management (VSM) .....	5-33
Vehicle weight .....	5-108
Overloading .....	5-108
Vehicle weight and luggage volume.....	8-5

## W

Warning and indicator lights .....	3-49
Air bag warning light.....	3-49

Anti-lock Brake System (ABS) warning light .....	3-50
AUTO STOP indicator light .....	3-55
Autonomous Emergency Braking (AEB) warning light .....	3-60
Charging system warning light .....	3-52
Cruise indicator light .....	3-58
Cruise SET indicator light .....	3-58
CUSTOM mode indicator light .....	3-59
ECO mode indicator light.....	3-59
ECS SPORT indicator light .....	3-55
Electric Power Steering (EPS) warning light .....	3-51
Electronic brake force warning light .....	3-51
Electronic Stability Control (ESC) indicator light .....	3-55
Electronic Stability Control (ESC) OFF indicator light.....	3-55
Engine oil pressure warning light .....	3-53
High beam indicator light.....	3-57
Icy road warning light .....	3-61
Immobilizer indicator light.....	3-56
Lane Departure Warning System (LDWS) warning light .....	3-60
Lane Keeping Assist System (LKAS) warning light.....	3-60
LED headlamp warning light .....	3-58
Light ON indicator light .....	3-57
Low beam indicator light.....	3-57
Low fuel level warning light .....	3-53
Low tire pressure warning light.....	3-54
Malfunction indicator lamp (MIL) .....	3-52
Master warning light.....	3-54

N mode indicator light.....	3-58	Winter driving.....	5-94
Parking brake & brake fluid warning light.....	3-49	Snow tires .....	5-94
Rear fog indicator light.....	3-57	Tire chains.....	5-95
REV (Rev Matching) indicator light .....	3-59	Winter Precautions.....	5-97
Seat belt warning light.....	3-49	Wiper blades replacement .....	7-30
Smart high beam indicator light .....	3-57	Front.....	7-31
Speed limiter indicator light .....	3-58	Rear.....	7-32
SPORT mode indicator light.....	3-58	Wipers and washers .....	3-91
Turn signal indicator light .....	3-57	Auto rear wiper .....	3-94
Warning light .....	3-49	Rear window wiper and washer switch.....	3-94
Washer fluid.....	7-26	Windshield washers .....	3-93
Welcome system .....	3-87	Windshield wipers .....	3-91
Headlamp and position lamp .....	3-87	Wireless cellular phone charging system .....	3-125
Interior lamp .....	3-87		
Door handle lamp .....	3-87		
Puddle lamp .....	3-87		
Wheel alignment and tire balance .....	7-40		
Wheel replacement .....	7-42		
Windows .....	3-27		
Auto up/down window .....	3-29		
Automatic reversal.....	3-29		
Power window lock switch.....	3-30		
Power windows.....	3-27		
Resetting the windows.....	3-29		
Windshield defrosting and defogging.....	3-115		
Windshield washers .....	3-93		
Front windshield wiper service position .....	3-93		
Windshield wipers .....	3-91		